

A-55905-6-M5

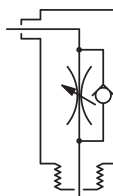

HAFNER

Škrtiaci-spätňý ventil tvar L - škrťí odfuk - do valca

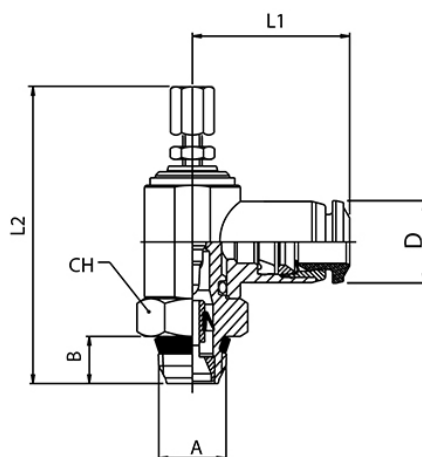

Typ	Priemer hadice	Prípoj A	B	L1	L2min	L2max	CH	D
A-55905-4-M5	4	M 5	5,5	19,5	38,5	42,5	8	10
A-55905-4-1/8	4	G 1/8"	5,5	21,5	44	49	14	10
A-55905-5-M5	5	M 5	5,5	20,5	38,5	42,5	8	12,5
A-55905-5-1/8	5	G 1/8"	5,5	22,5	44	49	14	12,5
A-55905-5-1/4	5	G 1/4"	7	25	48,5	55	17	12,5
A-55905-6-M5	6	M 5	5,5	21	38,5	42,5	8	12,5
A-55905-6-1/8	6	G 1/8"	5,5	23	44	49	14	12,5
A-55905-6-1/4	6	G 1/4"	7	25,5	48,5	55	17	12,5
A-55905-8-1/8	8	G 1/8"	5,5	23,5	44	49	14	14
A-55905-8-1/4	8	G 1/4"	7	26	48,5	55	17	14
A-55905-8-3/8	8	G 3/8"	8,5	27,5	56	65	20	14
A-55905-10-3/8	10	G 3/8"	8,5	30,5	56	65	20	17
A-55905-12-3/8	12	G 3/8"	8,5	32,5	56	65	20	21,5
A-55905-12-1/2	12	G 1/2"	10	35	62	69	24	21,5