

Katalóg pneumatických valcov 2020

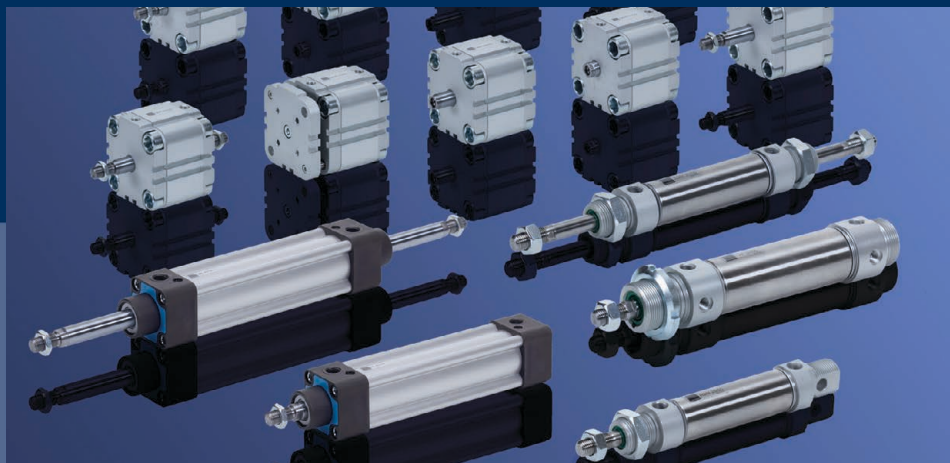

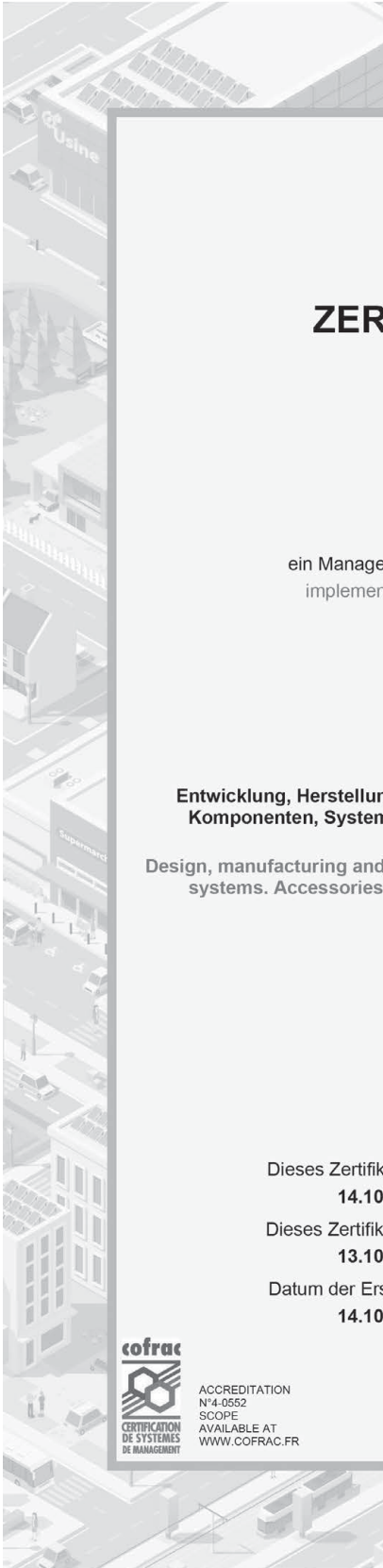

ZERTIFIKAT / CERTIFICATE

N°QMS-387874/h

Apave Certification bescheinigt, dass
Apave Certification certifies that

Hafner Pneumatika Kft.

ein Managementsystem am folgenden Standort implementiert hat
implemented a management system on the following location

**Püski út 3.
9228 Halászi**

für die folgenden Aktivitäten
for the following activities

**Entwicklung, Herstellung und Verkauf von pneumatischen und elektro-pneumatischen
Komponenten, Systemen und Zubehör für die Automatisierungstechnik und andere
Anwendungen**

**Design, manufacturing and sales of pneumatic as well as electro-pneumatic components and
systems. Accessories for industrial and process automation and other applications**

das gemäß den Anforderungen der Norm
which has been assessed to meet the

ISO 9001 : 2015

bewertet wurde.
standard's requirements.

Dieses Zertifikat ist gültig ab:
14.10.2019.

This certificate is valid from:
14.10.2019.

Dieses Zertifikat ist gültig bis:
13.10.2022.

This certificate is valid until:
13.10.2022.

Datum der Erstzertifizierung:
14.10.2013.

Initial certification date:
14.10.2013.

P. LABROUSSE



ACCREDITATION
N°4-0552
SCOPE
AVAILABLE AT
WWW.COFRAC.FR

Direktor der Apave Certification
Director of Apave Certification



AC-IMP-110-03h
Page 1/1

Apave Certification – 191, rue de Vaugirard – 75738 Paris Cedex 15 - SAS au capital de 117 143 € - RCS Paris 500 229 398 - SIRET : 500 229 398 00010 – APE : 7120B
Apave Certification est une marque déposée – Apave Certification is a registered trademark. Az Apave Certification bejegyzett, védjegyjelölalom alatt álló márka.

EN ISO 9001 : 2015

5	PNEUMATICKÉ VALCE ATEX	
6	Všeobecné informácie o výrobkoch Hafner do výbušného prostredia	NOVINKY
8	VŠEOBECNÉ TECHNICKÉ ÚDAJE K PNEUMATICKÝM VALCOM	
15	MINI VALCE	
17	CAF	
18	KRUHOVÉ VALCE ISO 6432	
20	REMV	
	RIM	
21	RDM	
	REM	
22	RBM	
	RIMA	
23	RIMR	
24	Príslušenstvo ku kruhovým valcom ISO 6432	
25	KRUHOVÉ VALCE	
27	AB/AD	
	AF/AH/AJ	NOVINKY
29	NIM/NDM	
30	NBM	
31	Príslušenstvo ku kruhovým valcom	
32	KOMPAKTNÉ VALCE ISO 21287	
34	ZEN/ZIN	
35	ZEF/ZIF	
36	ZENV	
37	ZEFV	
38	ZBN	
39	ZBF	
40	ZINT	
41	Príslušenstvo ku kompaktným valcom ISO 21287	
42	KOMPAKTNÉ VALCE UNITOP	
44	QEN/QIN/QBN	
45	QEF/QIF/QBF	
46	QENV	
47	QEFV	
48	QINT	
49	Príslušenstvo ku kompaktným valcom UNITOP	
50	KRÁTKOZDVIHOVÉ KOMPAKTNÉ VALCE	
52	BB/BF/BJ/BD	
53	BFA	
54	Krátkozdvihové kompaktné valce odolné voči vysokým teplotám	
56	BBV	
58	BDV	
60	BFK/BFV	
62	BJK/BJV	
64	RS	
65	RD	
66	SVORNÍKOVÉ KOMPAKTNÉ VALCE	
68	JEN/JEF/JIN/JIF	
	JBN/JBF	
69	JINT	
70	KOMPAKTNÉ VALCE S VEDENÍM	
72	A-CG01	
74	A-CG02	

75 A-CG04
81 CCIG6
83 CCBG6

85 **NORMALIZOVANÉ VALCE | ISO 15552**

87 HEF
88 HIF/HIFO/HBF
90 THIF
92 DIL/DILA/DBL
93 Príslušenstvo k normalizovaným valcom | ISO 15552

NOVINKY

94 **SVORNÍKOVÉ VALCE | ISO 15552**

96 DIM
98 UDM
99 UDMP

100 **PRÍTLAČNÉ VALCE**

102 SEJ/SDJ

103 **TLMIČE NÁRAZOV**

105 SH/SH C

106 **INOX**

108 Kruhové valce | ISO 6432
109 Kruhové valce
110 Kompaktné valce | ISO 21287
114 Normalizované valce | ISO 15552
116 Svorníkové valce | ISO 15552

117 **VALCE K NOŽOVÝM POSÚVAČOM**

119 LAZ

120 **VALCE S DVOJITOU PIESTNICOU**

122 DIFD
123 DBFD

124 **BEZPIESTNICOVÉ VALCE**

126 PL
127 PLF
128 PLK
129 PLG
130 PLR
131 PLS

132 **PRÍSLUŠENSTVO K VALCOM**

133 Príslušenstvo pre montáž na piestnu tyč
136 Príslušenstvo ku kruhovým valcom | ISO 6432
139 Príslušenstvo ku kruhovým valcom | Séria A
140 Príslušenstvo pre normalizované a kompaktné valce | ISO
147 Príslušenstvo pre kompaktné valce | UNITOP
149 Snímače polohy
151 Súpravy na opravu piestnicových valcov
152 Ostatné príslušenstvo
153 Lineárne vedenie pre kruhové valce | ISO 6432
155 Lineárne vedenie pre normalizované valce | ISO 15552

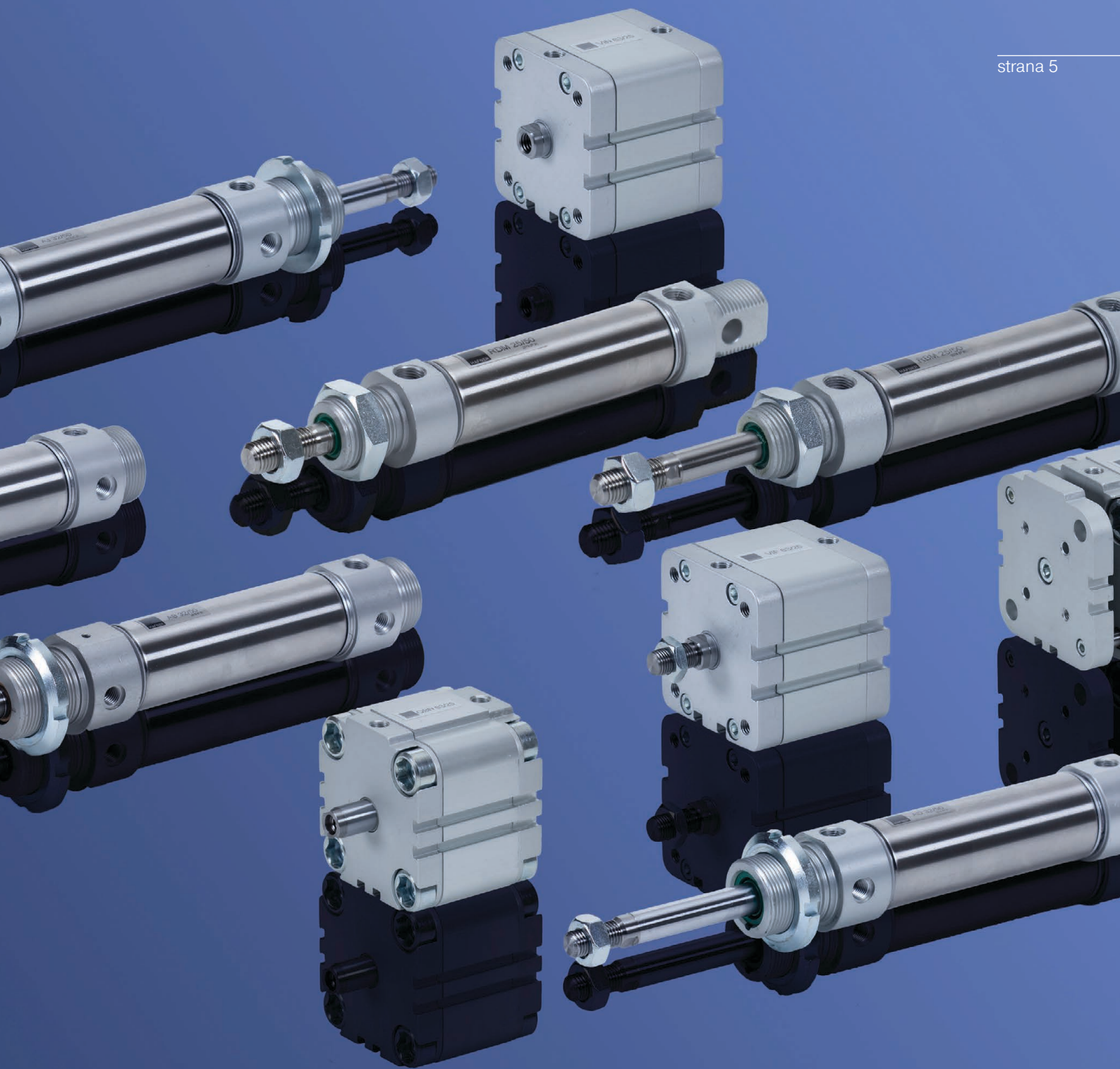

Pneumatické valce ATEX



Všeobecné informácie o výrobkoch Hafner do výbušného prostredia

Príklad označenia elektrického výrobku:
(V prípade ventilov)

Example marking of an **electric** product
CE  **II 2G mb IIC T4 Gb**

Príklad označenia neelektrického výrobku:
(V prípade valcov)

Example marking of a **non-electric** product
CE  **II 2G c T6 -10°C ≤ Ta ≤ 50°C**

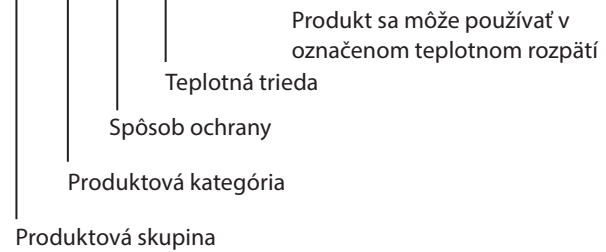

Produktová skupina:

Produktová skupina I

V I. produktovej skupine rozlišujeme výrobky typu M1 a M2. Oba typy sú vhodné pre banícke zariadenia. S touto produktovou skupinou sa ďalej nezaobráame, nakoľko NIE sú obsiahnuté v portfóliu Hafner.

Produktová skupina II

Do II. produktovej skupiny patria všetky ostatné výrobky do výbušného prostredia.

Produktová kategória:

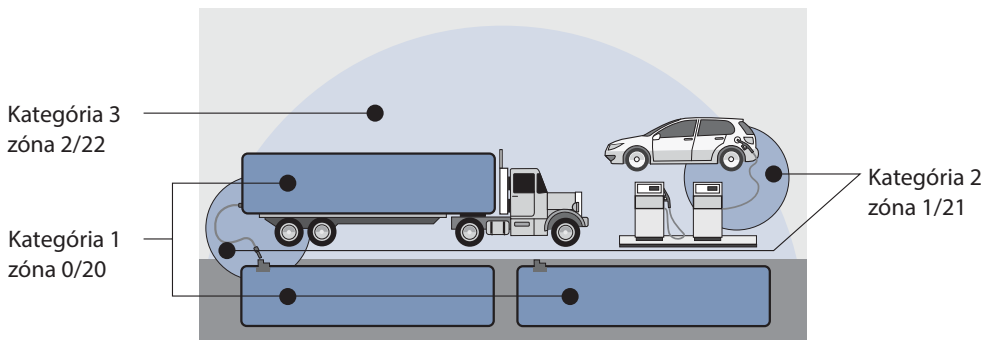

Kategória 1

Predstavuje prostredie, kde je výbušná zmes prítomná sústavne, alebo počas dlhej doby > 1 000 hodín/rok.

Kategória 2

Predstavuje prostredie, kde je výbušná zmes prítomná príležitostne 10 - 1 000 hodín/rok.

Kategória 3

Predstavuje prostredie, kde nie je pravdepodobné, že sa výbušná zmes vyskytne počas bežnej prevádzky, alebo ak sa vyskytne, tak je prítomná počas krátkej doby < 10 hodín/rok.

Všeobecné informácie o výrobkoch Hafner do výbušného prostredia

	Zóna (Plyn - G)	Zóna (Prach - D)
Kategória 1	Zóna O Také prostredie, kde výbušné ovzdušie pozostávajúce zo vzduchu a horľavých plynov, výparov alebo hmly je prítomné sústavne, alebo počas dlhej doby > 1 000 hodín/rok.	Zóna 20 Také prostredie, kde výbušné ovzdušie pozostávajúce z prachového závoja, alebo zmesi vzduchu a prachu je prítomné sústavne, alebo počas dlhej doby > 1 000 hodín/rok.
Kategória 2	Zóna 1 Také prostredie, kde za bežných podmienok je pravdepodobnosť výskytu výbušného ovzdušia pozostávajúceho zo vzduchu a horľavých plynov, výparov alebo hmly 10 - 1 000 hodín/rok.	Zóna 21 Také prostredie, kde za bežných podmienok je pravdepodobnosť výskytu výbušného ovzdušia pozostávajúceho z prachového závoja, alebo zmesi vzduchu a prachu 10 - 1 000 hodín/rok.
Kategória 3	Zóna 2 Také prostredie, kde výbušné ovzdušie pozostávajúceho zo vzduchu a horľavých plynov, výparov alebo hmly sa môže zriedkavo vyskytnúť < 10 hodín/rok.	Zóna 22 Také prostredie, kde výbušné ovzdušie pozostávajúceho z prachového závoja, alebo zmesi vzduchu a prachu sa môže zriedkavo vyskytnúť < 10 hodín/rok.

■ Dostupné v portfóliu Hafner

Spôsob protivýbušnej ochrany:

Konštrukcia systémov, zariadení a komponentov zabezpečuje, aby sa nestali zdrojom vznietenia počas štandardnej prevádzky, ani pri poruchovom chode.

Pre rôzne látky je charakteristická vlastnosť výbušnosti a iskrovej zápalnosti potenciálne výbušných zmesí. Výpary a plyny sú klasifikované do skupín. Kritériá rozdelenia sú maximálny experimentálny bezpečnostný interval a minimálny prúd vznietenia. Tie sú stanovené pri presne definovaných testovacích podmienkach pre rôzne výpary a plyny. Viď IEC60079-1A a IEC60079-3.

Riziko sa zvyšuje od skupiny IIA po skupinu IIC, čiže požiadavky na elektrické zariadenia sa zvyšujú. Teda výrobky klasifikované ako IIC môžu byť použité v IIB a IIA.

	Všeobecná definícia:	V prípade výrobkov Hafner
c	Konštrukčná bezpečnosť	Všeobecná mechanická ATEX ochrana
i	Iskrová bezpečnosť	ia označenie na elektromagnetických cievkach
na	Neiskriaci	
m	Zapuzdrenie	S káblom
me	Zapuzdrenie so zvýšenou bezpečnosťou	Ex emb s elektroinštaláčnou krabicou
d	Ohňovzdorný kryt	S elektroinštaláčnou krabicou
dm	Ohňovzdorné zapuzdrenie	S elektroinštaláčnou krabicou

Teplotná trieda:

Teplotná trieda	Teplota vznietenia plynov a výparov	Max. povolená povrchová teplota zariadenia
T1	450°C	450°C
T2	350°C - 450°C	300°C
T3	200°C - 300°C	200°C
T4	135°C - 200°C	135°C
T5	100°C - 135°C	100°C
T6	85°C - 100°C	85°C

T6 obsahuje všetky ostatné teplotné triedy.

Všeobecné technické údaje k pneumatickým valcom

Sila pružiny, prítlačná a ťažná sila kruhových valcov | ISO 6432

		Zdvih [mm]												
		10	25	50										
Ø [mm]		Sila pružiny [N]**												
Ø 8	A	4,1	3,5	2,6										
	B	4,5	4,5	4,5										
Ø 10	A	4,1	3,5	2,6										
	B	4,5	4,5	4,5										
Ø 12	A	5,5	4,8	3,5										
	B	6	6	6										
Ø 16	A	16,5	13,7	9										
	B	18,3	18,3	18,3										
Ø 20	A	19	15,5	9,5										
	B	21,5	21,5	21,5										
Ø 25	A	27	24	13,5										
	B	29	29	29										
					[N]*	Ø8	Ø10	Ø12	Ø16	Ø20	Ø25			
REM	Prítlačná sila				30	42	60	108	168	264				
	Ťažná sila				-	-	-	-	-	-				
RIM	Prítlačná sila				30	42	60	108	168	264				
	Ťažná sila				18	36	45	96	144	216				
RBM	Prítlačná sila				-	-	-	108	168	264				
	Ťažná sila				-	-	-	96	144	216				
RDM	Prítlačná sila				-	-	-	108	168	264				
	Ťažná sila				-	-	-	96	144	216				

Sila pružiny, prítlačná a ťažná sila kruhových valcov

		Zdvih [mm]										
		10	25	50								
Ø [mm]		Sila pružiny [N]**										
Ø 32	A	56	51	42								
	B	60	60	60								
Ø 40	A	60	55	44								
	B	65	65	65								
Ø 50	A	64	57	46								
	B	68	68	68								
Ø 63	A	65	58	47								
	B	70	70	70								
					[N]*	Ø32	Ø40	Ø50	Ø63			
A_	Prítlačná sila				432	660	1050	1680				
	Ťažná sila				372	570	888	1500				

Prítlačná a ťažná sila valcov s dvojitou piestnicou

		[N]*	Ø32	Ø40	Ø50	Ø63	Ø80	Ø100	Ø125	Ø160	Ø200	Ø250	Ø320
N_	Prítlačná sila		432	660	1050	1680	2700	4200	6624	10645	16633	25990	42582
	Ťažná sila		372	570	888	1500	2430	3960	6192	9980	15968	24950	40932

Prítlačná a ťažná sila kompaktných valcov | UNITOP

	[N]*	Ø12	Ø16	Ø20	Ø25	Ø32	Ø40	Ø50	Ø63	Ø80	Ø100
QIN	Prítlačná sila	68	121	188	295	482	754	1178	1869	3014	4710
	Ťažná sila	51	90	141	247	415	687	1058	1750	2829	4420
QEN	Prítlačná sila	68	121	188	295	483	754	1178	1870	3016	4712
	Ťažná sila	8	13	17	22	30	36	35	65	94	156
QENV	Prítlačná sila	51	90	141	247	415	686	1057	1750	2827	4418
	Ťažná sila	8	13	17	22	30	36	35	65	94	156
QBN	Prítlačná sila	51	90	141	247	415	686	1057	1750	2827	4418
	Ťažná sila	51	90	141	247	415	686	1057	1750	2827	4418
QINT	Prítlačná sila	68	121	188	295	483	754	1178	1870	3016	4712
	Ťažná sila	51	90	141	247	415	686	1057	1750	2827	4418

Sila pružiny, prítlačná a ťažná sila krátkozdvihových kompaktných valcov

Ø [mm]		Zdvih [mm]				
		5	10	15	20	25
		Sila pružiny [N]**				
Ø 12	A	7,5	6,8	6	5,2	4,5
	B	8	8	8	8	8
Ø 16	A	12,3	10,8	9,5	7,8	6,5
	B	13,3	13,3	13,3	13,3	13,3
Ø 20	A	15,7	14	12,2	10,4	8,7
	B	17,4	17,4	17,4	17,4	17,4
Ø 25	A	19,5	18,5	17,3	16	15
	B	22	22	22	22	22
Ø 32	A	27,8	25,3	22,8	20,2	17,7
	B	30	30	30	30	30
Ø 40	A	36,4	34	31,7	29,5	27
	B	36	36	36	36	36
Ø 50	A	32	30,5	29	27,8	26,5
	B	35	35	35	35	35
Ø 63	A	61	58,5	56,3	53,5	51,5
	B	64,8	64,8	64,8	64,8	64,8
Ø 80	A	91,3	88	85	82	78,7
	B	94	94	94	94	94
Ø 100	A	150	145	140	134	129
	B	156	156	156	156	156

RD	Prítlačná	68	-	189	-	483	-	1178	1870	-	-
	Ťažná sila	51	-	141	-	415	-	1056	1750	-	-
B_	Prítlačná	60	105	170	264	432	660	1050	1680	2700	4200
	Ťažná sila	45	80	125	216	372	600	930	1560	2520	3960

Všeobecné technické údaje k pneumatickým valcom

Prítlačná a ťažná sila svorníkových kompaktných valcov

	[N]*	Ø125	Ø160	Ø200	Ø250
JEN, JEF, JIN, JIF	Prítlačná sila	7280	11960	18720	29350
	Ťažná sila	6880	11200	17960	28600
JINT, JBF, JBN	Prítlačná sila	6880	11200	17960	28600
	Ťažná sila	6880	11200	17960	28600

Prítlačná a ťažná sila kompaktných valcov s vedením

	[N]*	Ø6	Ø8	Ø12	Ø16	Ø20	Ø25	Ø32	Ø40	Ø50	Ø63
A-CG01	Prítlačná sila	-	-	59,9	106,5	166,3	259,9	425,8	665,4	1039,6	1650,5
	Ťažná sila	-	-	44,9	79,8	124,8	200,0	319,4	558,9	873,2	1484,1
A-CG02	Prítlačná sila	29,9	-	119,8	213,0	332,6	519,8	851,6	-	-	-
	Ťažná sila	16,6	-	89,8	159,6	249,6	400,0	638,8	-	-	-
A-CG04	Prítlačná sila	34,0	61,0	136,0	241,0	377,0	589,0	-	-	-	-
	Ťažná sila	25,0	45,0	102,0	181,0	283,0	454,0	-	-	-	-

Prítlačná a ťažná sila normalizovaných valcov | ISO 15552

	[N]*	Ø32	Ø40	Ø50	Ø63	Ø80	Ø100	Ø125	Ø160	Ø200	Ø250	Ø320
HEF	Prítlačná sila	432	660	1050	1680	2700	4200	6624	10645	16633	25990	42582
	Ťažná sila	372	570	888	1500	2430	3960	6192	9980	15968	24950	40932
DIL	Prítlačná sila	483	754	1178	1870	3016	4712	7363	-	-	-	-
	Ťažná sila	415	633	990	1682	2721	4418	6881	-	-	-	-
DBL	Prítlačná sila	415	633	990	1682	2721	4418	6881	-	-	-	-
	Ťažná sila	415	633	990	1682	2721	4418	6881	-	-	-	-
HIF	Prítlačná sila	483	754	1178	1870	3016	4712	7363	-	-	-	-
	Ťažná sila	415	633	990	1682	2721	4418	6881	-	-	-	-

Prítlačná a ťažná sila svorníkových valcov | ISO 15552

	[N]*	Ø160	Ø200	Ø250	Ø320
DIM	Prítlačná sila	12064	18850	29452	48255
	Ťažná sila	11310	18096	28274	46558
UDM	Prítlačná sila	12064	18850	29450	48250
	Ťažná sila	11310	18096	29470	46380
UDMP	Prítlačná sila	11310	18096	29470	46380
	Ťažná sila	11310	18096	29470	46380

* Teoretické sily pri tlaku 6 bar - kvôli treniu v praxi počítajte prosím s hodnotou menšou o približne 5%!

Všeobecné technické údaje k pneumatickým valcom

Prítlačná a ťažná sila valcov k nožovým posúvačom

	[N]*	Ø80	Ø100	Ø125	Ø160	Ø200	Ø250	Ø320
LAZ	Prítlačná sila	3014	4710	7359	12057	18840	29437	48230
	Ťažná sila	2826	4521	6877	11575	18086	28683	47476

Prítlačná a ťažná sila kompaktných valcov | ISO 21287

	[N]*	Ø20	Ø25	Ø32	Ø40	Ø50	Ø63	Ø80	Ø100
VIN/VIF	Prítlačná sila	188	295	482	754	1178	1869	3014	4710
	Ťažná sila	142	248	415	687	1058	1750	2829	4420
VINT	Prítlačná sila	188	295	482	754	1178	1869	3014	4710
	Ťažná sila	142	248	415	687	1058	1750	2829	4420
VBF/VBN	Prítlačná sila	142	248	415	687	1058	1750	2829	4420
	Ťažná sila	142	248	415	687	1058	1750	2829	4420

Sily pôsobiace na bezpečnicové valce | PL/PLF

Piest	Prítlačná sila	Max. zataženie	Max. ohybový moment PL/PLF		Max. krútiaci moment PL/PLF
Ø [mm]	F [N]*	L [N]	Ma [Nm] axiálny	Mr [Nm] radiálny	Mv [Nm] centrálny
Ø 16	110	120	4 / 4	0,3 / 0,45	0,5 / 0,5
Ø 25	250	300	15 / 15	1 / 1,5	3 / 3
Ø 32	420	450	30 / 30	2 / 3	4,5 / 4,5
Ø 40	640	750	60 / 60	4 / 6	8 / 8
Ø 50	1000	1200	- / 115	- / 10	- / 15
Ø 63	1550	1650	- / 200	- / 12	- / 24

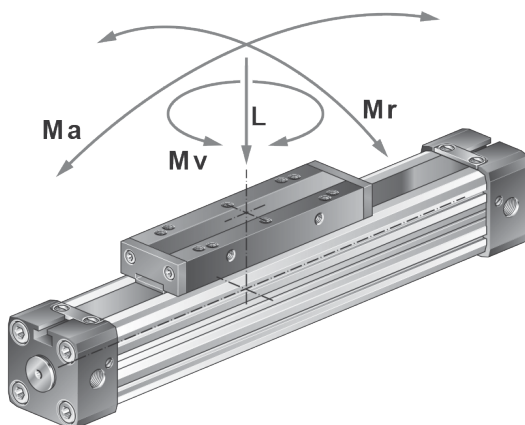

* Teoretické sily pri tlaku 6 bar - kvôli treniu v praxi počítajte prosím s hodnotou menšou o približne 5%!

Všeobecné technické údaje k pneumatickým valcom

Sily pôsobiace na bezpečnicové valce | PLG

Piest Ø [mm]	Prítlačná sila F [N]*	Max. zaťaženie L [N]	Max. ohybový moment		Max. krútiaci moment
			Ma [Nm] axiálny	Mr [Nm] radiálny	Mv [Nm] centrálny
Ø 16	110	350	6	4	6
Ø 25	250	1000	40	14	40
Ø 32	420	2000	68	24	68
Ø 40	640	2800	103	37	103

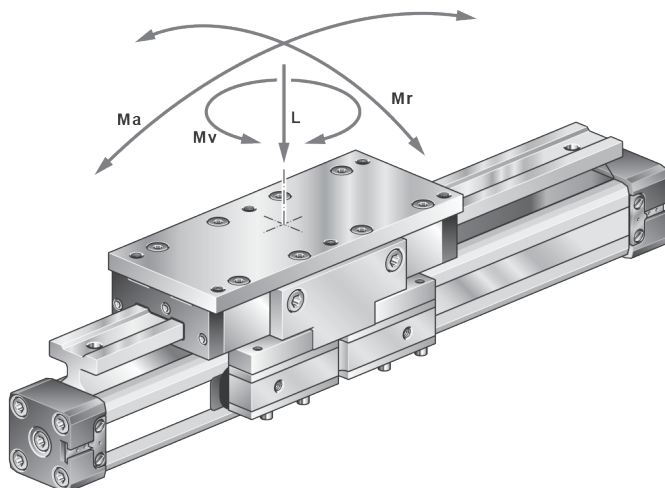

Sily pôsobiace na bezpečnicové valce | PLK

Piest Ø [mm]	Prítlačná sila F [N]*	Max. zaťaženie L [N]	Max. ohybový moment		Max. krútiaci moment
			Ma [Nm] axiálny	Mr [Nm] radiálny	Mv [Nm] centrálny
Ø 16	110	500	4	6	11
Ø 25	250	1500	40	14	40
Ø 32	420	2950	61	30	62
Ø 40	640	3960	115	52	70
Ø 50	1000	7500	580	210	580
Ø 63	1550	7500	580	210	85

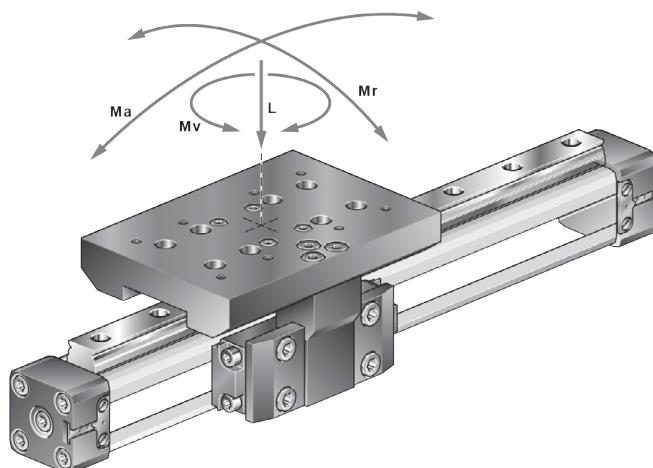

Všeobecné technické údaje k pneumatickým valcom

Sily pôsobiace na bezpečnostné valce | PLS

Piest Ø [mm]	Prítlačná sila F [N]*	Max. zaťaženie L [N]	Max. ohybový moment		Max. krútiaci moment
			Ma [Nm] axiálny	Mr [Nm] radiálny	Mv [Nm] centrálny
Ø 32	420	760	39	15	39
Ø 40	640	1330	99	35	99
Ø 50	1000	1600	170	58	170
Ø 63	1550	2770	315	105	317

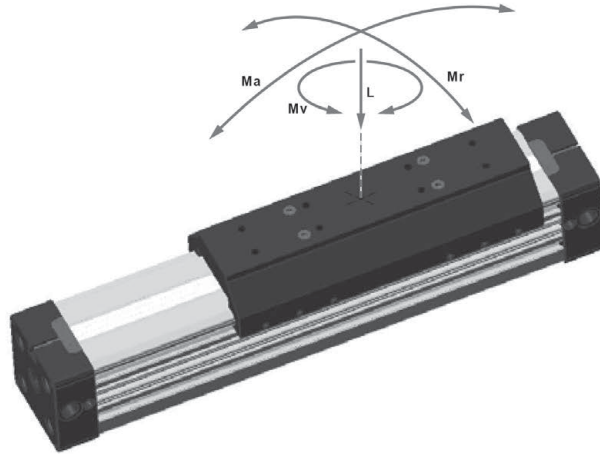



HAFNER Pneumatika Kft.





Mini valce

Mini valce

strana 16

Všeobecný opis

Priemer piestu Ø6 - Ø10 - Ø16 mm

Štandardný zdvih 5 - 10 - 15 mm

Pracovné médium stlačený vzduch

Pracovný tlak 2 ... 7 bar

Teplota okolia -20°C ... +80°C

Pri teplotách pod 0°C je potrebné používať vhodne pripravený, suchý stlačený vzduch.

Použitý materiál

Teleso valca poniklovaná mosadz

Kryt poniklovaná mosadz

Piest mosadz

Piestnica nehrdzavejúca oceľ

Vodiace puzdro sintrovaný bronz

Tesnenia polyuretán

C	A	F	6	/	10
			PRIEMER		ZDVIH
			6		5
			10		10
			16		15

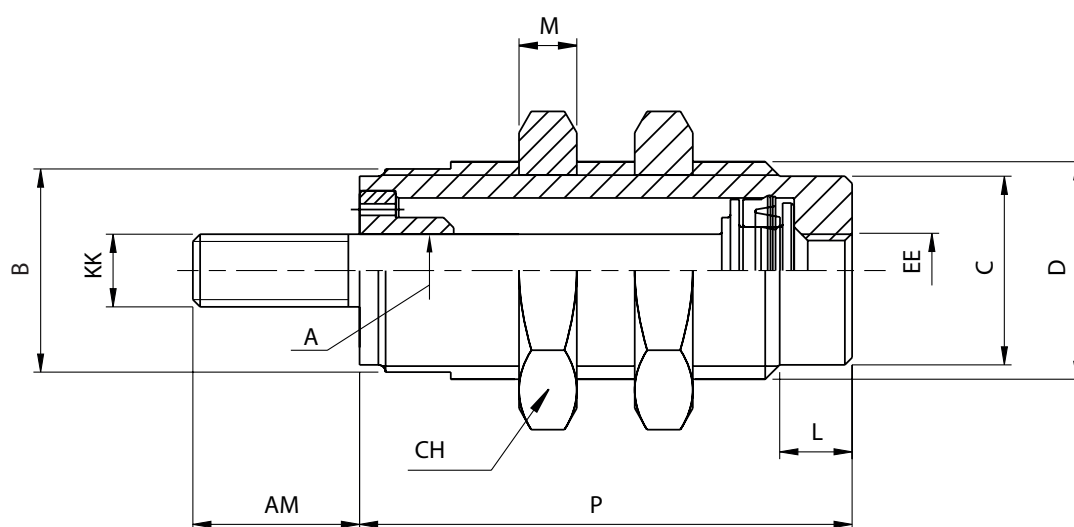

Typ	Ø [mm]	A	B	C	D	L	M	P	AM	ØKK	EE	CH
CAF 6/5	Ø 6	3	9	8,5	M10x1	5	3	18,5	8	3	M5	14
CAF 6/10	Ø 6	3	9	8,5	M10x1	5	3	26,5	8	3	M5	14
CAF 6/15	Ø 6	3	9	8,5	M10x1	5	3	33,5	8	3	M5	14
CAF 10/5	Ø 10	4	14	13	M15x1,5	5	4	21,5	10,5	5	M5	19
CAF 10/10	Ø 10	4	14	13	M15x1,5	5	4	28	10,5	5	M5	19
CAF 10/15	Ø 10	4	14	13	M15x1,5	5	4	35	10,5	5	M5	19
CAF 16/5	Ø 16	5	20	19	M22x1,5	6	5	24,5	13	5	M5	27
CAF 16/10	Ø 16	5	20	19	M22x1,5	6	5	30,5	13	5	M5	27
CAF 16/15	Ø 16	5	20	19	M22x1,5	6	5	37	13	5	M5	27



Kruhové valce | ISO 6432

Všeobecný opis	
Priemer piestu	Ø8 - Ø10 - Ø12 - Ø16 - Ø20 - Ø25 mm
Štandardný zdvih	10 - 25 - 40 - 50 - 80 - 160 - 200 - 250 - 320 mm (v závislosti od priemeru)
	Jednočinný
	Dvojčinný
Pracovné médium	stlačený vzduch
Pracovný tlak	1 ... 10 bar
Teplota okolia	-20°C ... +80°C
	0°C ... +150°C v prípade FPM tesnenia
	Pri teplotách pod 0°C je potrebné používať vhodne pripravený, suchý stlačený vzduch.

Použitý materiál	
Teleso valca	nehrdzavejúca oceľ
Kryt	eloxovaný hliník
Piest	mosadz
Piestnica	nehrdzavejúca oceľ
Vodiace puzdro	sintrovaný bronz
Tesnenia	polyuretán, NBR/FPM (v závislosti od typu)

R I M A 8 / 125 Ex

PRIEMER

8
10
12
16
20
25*

ZDVIH

10
25
40
50
80
100
125
160
200
250
320

MOŽNOSTI

⊕ II 2 GD c T6 -20°C < Tamb < 80°C

VERZIE

PRÁZDNE	Štandardné tesnenie, piestnica z nehrdzavejúcej ocele
F	FPM tesnenie (v prípade valcov REM)
V	Vysunutá piestnica (v prípade valcov REM, od Ø16 mm)
VK	Vysunutá piestnica, FPM tesnenie stierača (v prípade valcov REM, od Ø16 mm)
VF	Vysunutá piestnica, FPM tesnenie (v prípade valcov REM, od Ø16 mm)
R	Špeciálne veko, radiálny prípoj stl. vzduchu (v prípade valcov RIM)
A	Špeciálne veko, axiálny prípoj stl. vzduchu (v prípade valcov RIM)
O	Piestnica zaistená proti pootočeniu (v prípade valcov RIM, od Ø16 mm)
K	FPM tesnenie stierača (v prípade valcov RIM, RBM, RDM)
V	FPM tesnenie (v prípade valcov RIM, RBM, RDM)

VERZIE

E	Jednočinný valec
I	Dvojčinný valec
B	Dvojčinný valec, priebežná piestnica (od Ø16 mm)
D	Dvojčinný valec, nastaviteľné tlmenie (od Ø16 mm)

* Na požiadanie dostupné aj v prevedení s dutou tyčou na vakuom

REMV

strana 20

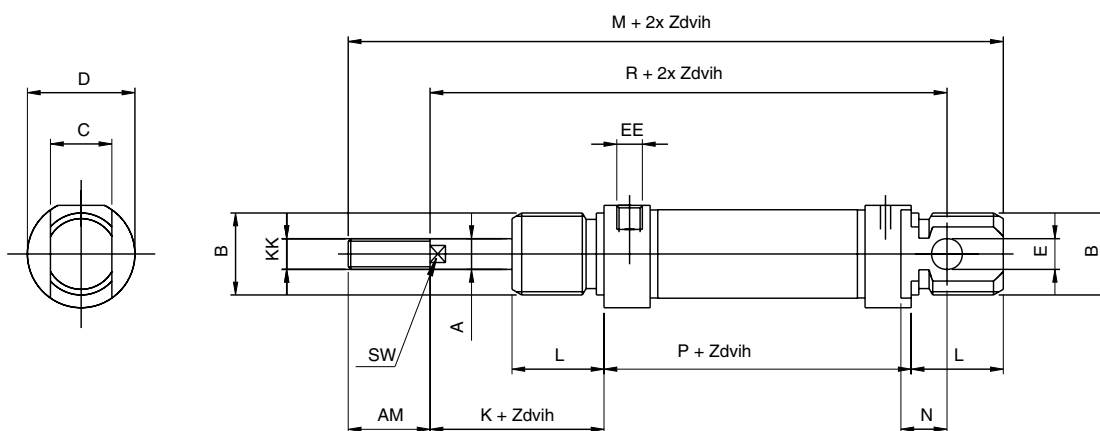

Ø [mm]	A	B	C	D	E	K	L	M	N	P	R	AM	EE	KK	SW
Ø 16	6	M16x1,5	12	19	6	22	18	134,5	9	78,5	107,5	16	M5	M6	5
Ø 20	8	M22x1,5	16	27	8	24	20	154	12	90	118	20	G1/8"	M8	7
Ø 25	10	M22x1,5	16	30	8	28	22	166	12	94	130	22	G1/8"	M10x1,25	9

RIM

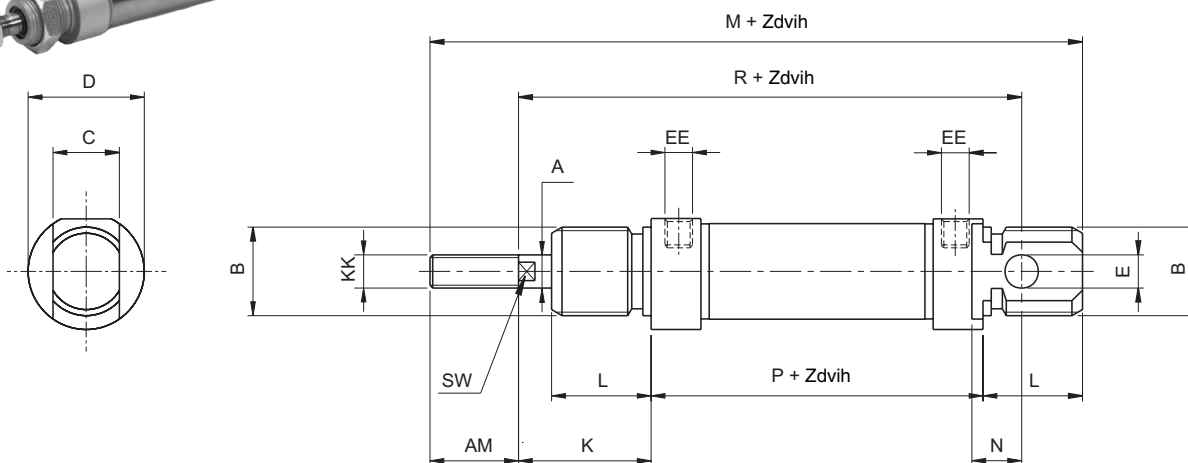
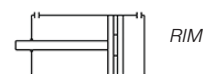

Ø [mm]	A	B	C	D	E	K	L	M	N	P	R	AM	EE	KK	SW
Ø 8	4	M12x1,25	8	16	4	16	12	86	6	46	64	12	M5	M4	-
Ø 10	4	M12x1,25	8	16	4	16	12	86	6	46	64	12	M5	M4	-
Ø 12	6	M16x1,5	12	19	6	22	18	104	9	48	75	16	M5	M6	5
Ø 16	6	M16x1,5	12	19	6	22	18	109	9	53	82	16	M5	M6	5
Ø 20	8	M22x1,5	16	27	8	24	20	131	12	67	95	20	G1/8"	M8	7
Ø 25	10	M22x1,5	16	30	8	28	22	140	12	68	104	22	G1/8"	M10x1,25	9

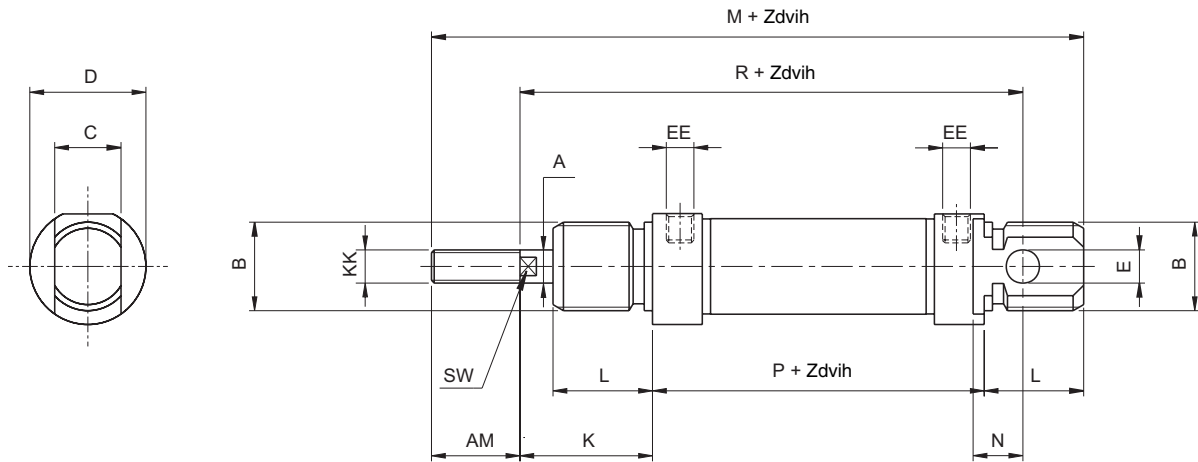
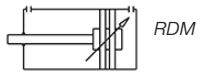

Ø [mm]	A	B	C	D	E	K	L	M	N	P	R	AM	EE	KK	SW
Ø 16	6	M16x1,5	12	21	6	22	18	109	9	53	82	16	M5	M6	25
Ø 20	8	M22x1,5	16	27	8	24	20	131	12	67	95	20	G1/8"	M8	7
Ø 25	10	M22x1,5	16	30	8	28	22	140	12	68	104	22	G1/8"	M10x1,25	9

REM

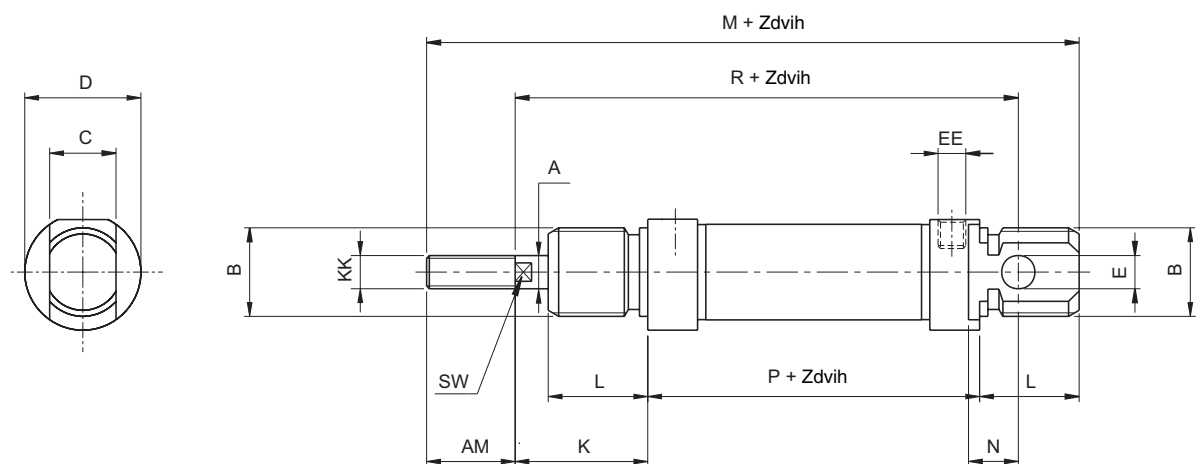

Ø [mm]	A	B	C	D	E	K	L	M	N	P	R	AM	EE	KK	SW
Ø 8	4	M12x1,25	8	16	4	16	12	86	6	46	64	12	M5	M4	-
Ø 10	4	M12x1,25	8	16	4	16	12	86	6	46	64	12	M5	M4	-
Ø 12	6	M16x1,5	12	19	6	22	18	104	9	48	75	16	M5	M6	5
Ø 16	6	M16x1,5	12	19	6	22	18	109	9	53	82	16	M5	M6	5
Ø 20	8	M22x1,5	16	27	8	24	20	131	12	67	95	20	G1/8"	M8	7
Ø 25	10	M22x1,5	16	30	8	28	22	140	12	68	104	22	G1/8"	M10x1,25	9

RBM

strana 22

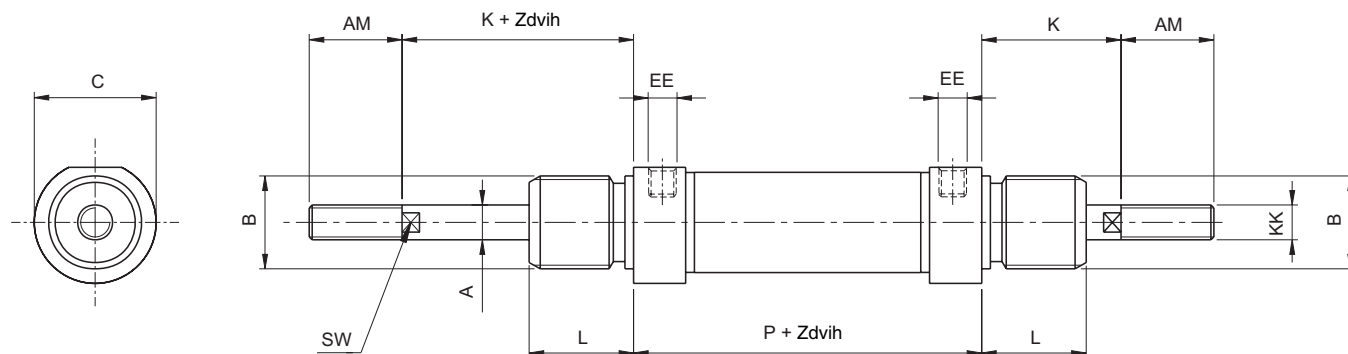
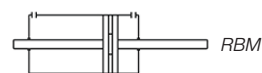

Ø [mm]	A	B	C	K	L	P	AM	EE	KK	SW
Ø 16	6	M16x1,5	19	22	18	53	16	M5	M6	5
Ø 20	8	M22x1,5	27	24	20	67	20	G1/8"	M8	7
Ø 25	10	M22x1,5	30	28	22	68	22	G1/8"	M10x1,25	9

RIMA

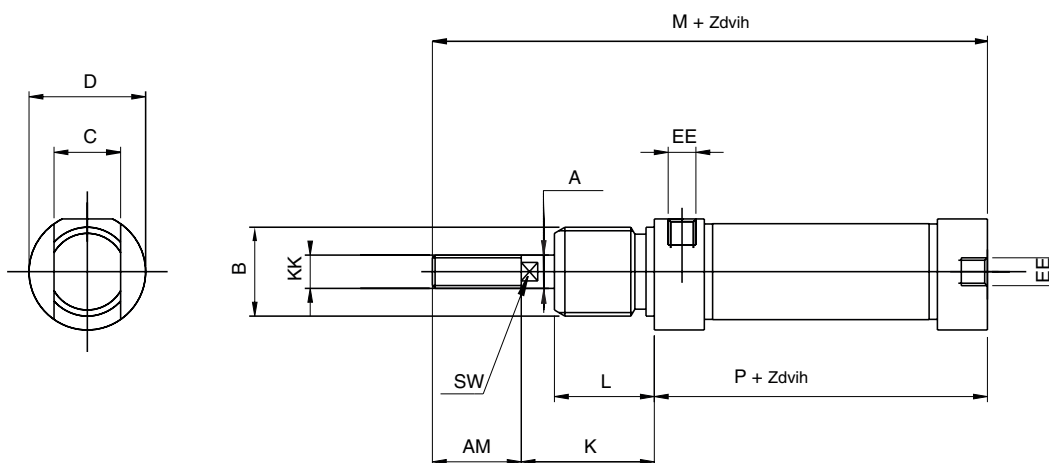
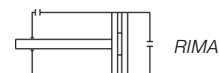

Ø [mm]	A	B	C	D	K	L	M	P	AM	EE	KK	SW
Ø 16	6	M16x1,5	12	21	22	18	91,5	53	16	M5	M6	5
Ø 20	8	M22x1,5	16	27	24	20	111,5	67	20	G1/8"	M8	7
Ø 25	10	M22x1,5	16	30	28	22	118,5	68	22	G1/8"	M10x1,25	9

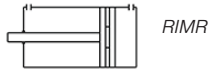

RIMR

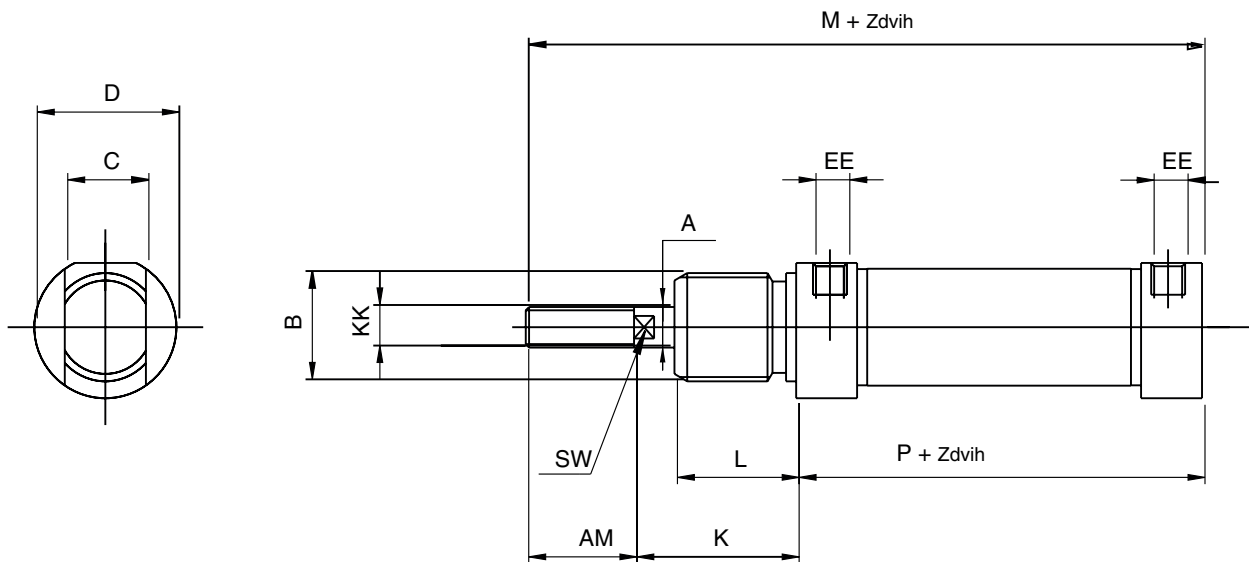

Ø [mm]	A	B	C	D	K	L	M	P	AM	EE	KK	SW
Ø 16	6	M16x1,5	12	21	22	18	91,5	53	16	M5	M6	5
Ø 20	8	M22x1,5	16	27	24	20	111,5	67	20	G1/8"	M8	7
Ø 25	10	M22x1,5	16	30	28	22	118,5	68	22	G1/8"	M10x1,25	9

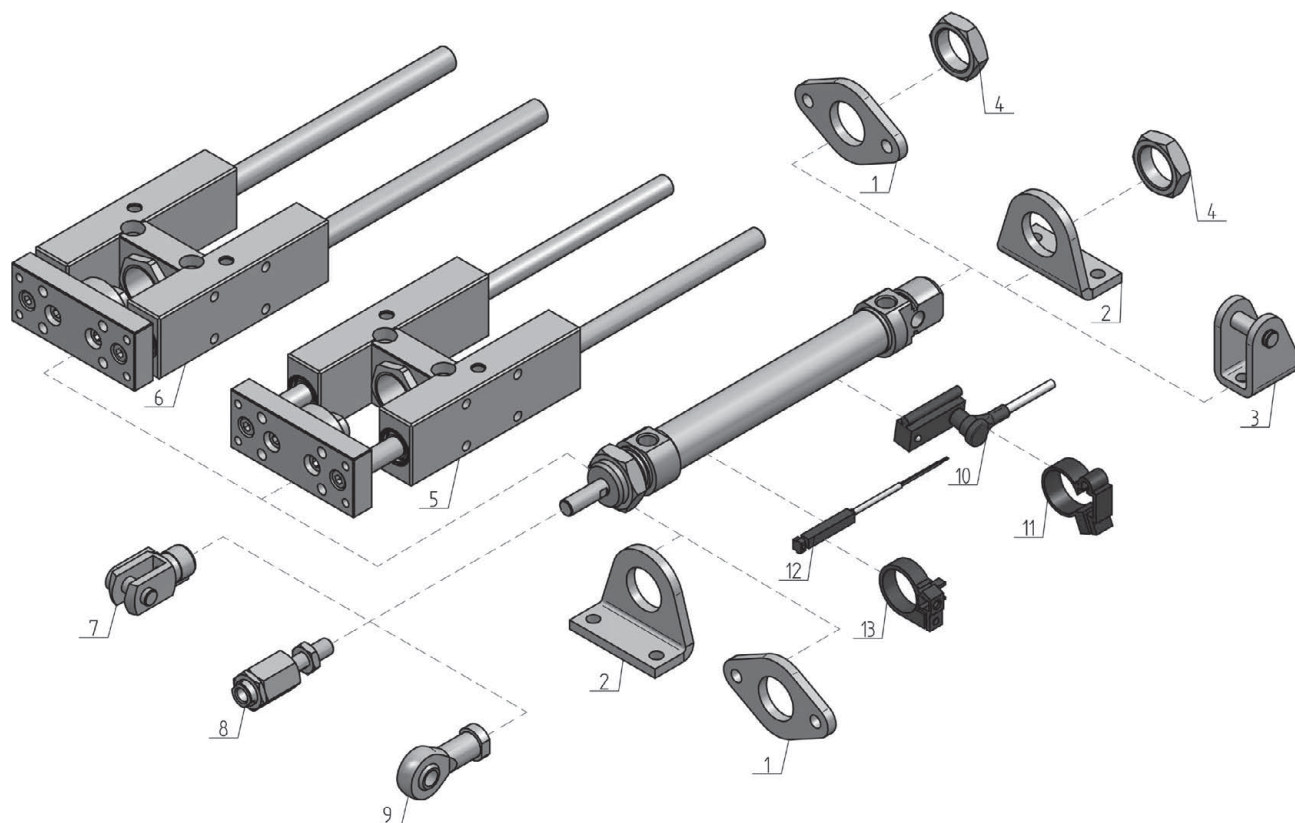

Označenie	Typ	Pomenovanie	Strana
1	RF/RFX	Príruba - k valcom série R	136
2	RL	Pätkové upevnenie - k valcom série R	137
2	RLX	Pätkové upevnenie z nehrdzavejúcej ocele - k valcom série R	137
3	RG	Ložiskové puzdro - k valcom série R	137
3	RGX	Ložiskové puzdro z nehrdzavejúcej ocele - k valcom série R	137
4	RA	Upevňovacia matica - k valcom série R	138
4	RAX	Upevňovacia matica z nehrdzavejúcej ocele - k valcom série R	138
5	RHS	Lineárne H vedenie - klzné ložisko	153
5	RHSL	Lineárne H vedenie - klzné ložisko	154
6	RHG/RHGL	Lineárne H vedenie - guľôčkové ložisko	154
7	UV	Vidlicová koncovka s upevňovacím čapom	134
8	FK	Flexibilná spojka	136
9	UK	Kĺbová hlavica	135
9	UKF	Kĺbová hlavica	133
10	SM	Snímač - REED relé / jazýčkové relé	150
11	RX	Upevňovacia jednotka pre SM snímač	150
12	SKR/SKH	Snímač	149
13	RXP	Upevňovacia jednotka pre SKR/SKH snímač	150



Kruhové valce

Kruhové valce

strana 26

Všeobecný opis	
Priemer piestu	Ø32 - Ø40 - Ø50 - Ø63 mm
Štandardný zdvih	10 - 25 - 50 - 80 - 100 - 125 - 160 - 200 - 250 - 320 - 400 - 500 mm
	Jednočinný
	Dvojčinný
Pracovné médium	stlačený vzduch
Pracovný tlak	1 ... 10 bar
Teplota okolia	-20°C ... +80°C
	0°C ... +150°C v prípade FPM tesnenia
	Pri teplotách pod 0°C je potrebné používať vhodne pripravený, suchý stlačený vzduch.
Použitý materiál	
Teleso valca	nehrdzavejúca oceľ
Kryt	eloxovaný hliník
Piest	eloxovaný hliník
Piestnica	tvrdá chrómovaná oceľ / nehrdzavejúca oceľ - AISI 316 (v závislosti od typu)
Vodiace puzdro	sintrovaný bronz
Tesnenia	polyuretán, NBR/FPM (v závislosti od typu)

A	F	K	32	/	80	Ex
			PRIEMER		ZDVIH	MOŽNOSTI
			32		10	II 2 GD c T6 -20°C < Tamb < 80°C (v prípade AB, AD, AF, AH, AJ)
			40		25	
			50		50	
			63		80	
					100	
					125	
					160	
					200	
					250	
					320	
					400	
					500	
			VERZIE			
			PRÁZDNE Štandardné tesnenie, piestnica z tvrdo chrómovanej ocele R Piestnica z nehrdzavejúcej ocele (AISI 316) (v prípade valcov AB, AD, AF, AH) RK Piestnica z nehrdzavejúcej ocele (AISI 316), FPM tesnenie stierača (v prípade valcov AF, AH) RV Piestnica z nehrdzavejúcej ocele (AISI 316), FPM tesnenie (v prípade valcov AF, AH) K FPM tesnenie stierača (v prípade valcov AF, AH) V FPM tesnenie (v prípade valcov AF, AH)			
			VERZIE			
			B Jednočinný valec D Jednočinný valec, vysunutá piestnica F Dvojčinný valec H Dvojčinný valec, nastaviteľné tlmenie J Dvojčinný valec, priebežná piestnica			

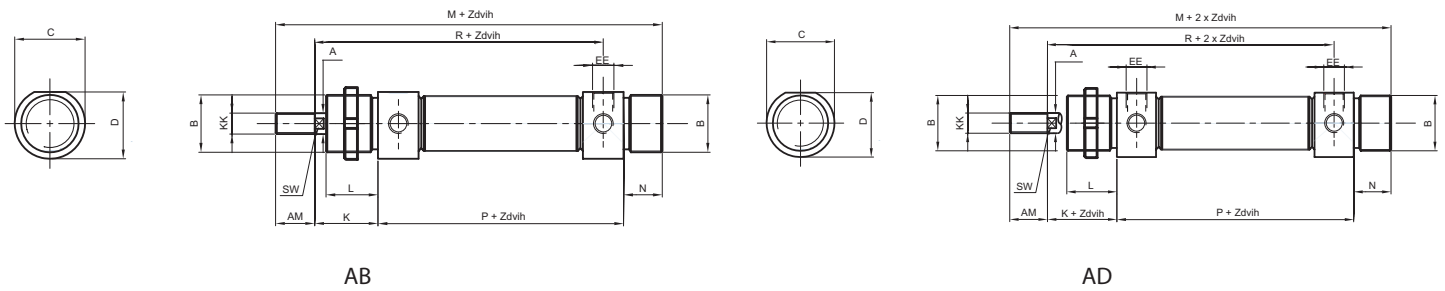

AB

AD

Ø [mm]	A	B	C	D	K	L	M	N	P	R	AM	EE	KK	SW
Ø 32	12	M30x1,5	38	36,5	38	30	168	14	96	125	20	G 1/8"	M10x1,25	10
Ø 40	16	M38x1,5	46	44	45	35	196 (198)*	16	111 (113)*	144 (146)*	24	G 1/4"	M12x1,25	12
Ø 50	20	M45x1,5	57	55	50	38	220	18	120	158	32	G 1/4"	M16x1,5	16
Ø 63	20	M45x1,5	70	67,5	50	38	224	18	124	161	32	G 3/8"	M16x1,5	16

AF/AH/AJ

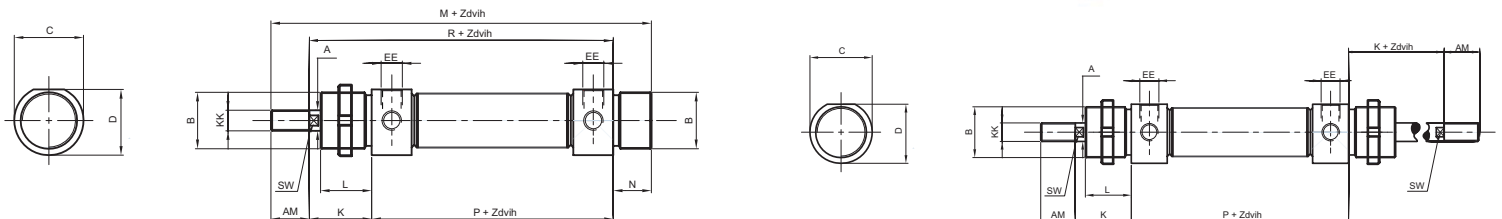
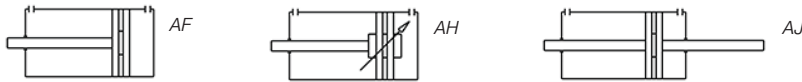

AF/AH

AJ

Ø [mm]	A	B	C	D	K	L	M	N	P	R	AM	EE	KK	SW
Ø 32	12	M30x1,5	38	36,5	38	30	168	14	96	125	20	G 1/8"	M10x1,25	10
Ø 40	16	M38x1,5	46	44	45	35	196 (198)*	16	111 (113)*	144 (146)*	24	G 1/4"	M12x1,25	12
Ø 50	20	M45x1,5	57	55	50	38	220	18	120	158	32	G 1/4"	M16x1,5	16
Ø 63	20	M45x1,5	70	67,5	50	38	224	18	124	161	32	G 3/8"	M16x1,5	16

* V prípade valcov s neštandardným zdvihom, ako aj u valcov ABR, ADR, AFR, AFK, AFRK, AFV, AFRV, AHR, AHK, AHRK, AHV, AHRV.

Kruhové valce

strana 28

Všeobecný opis

Priemer piestu	Ø32 - Ø40 - Ø50 - Ø63 mm
Štandardný zdvih	25 - 50 - 80 - 100 - 125 - 160 - 200 - 250 - 320 - 400 - 500 - 600 - 700 - 800 - 900 - 1000 mm
Pracovné médium	stlačený vzduch
Pracovný tlak	1 ... 10 bar
Teplota okolia	-20°C ... +80°C
	0°C ... +150°C v prípade FPM tesnenia

Pri teplotách pod 0°C je potrebné používať vhodne pripravený, suchý stlačený vzduch.

Použitý materiál

Teleso valca	nehrdzavejúca oceľ
Kryt	eloxovaný hliník
Piest	bronz
Piestnica	tvrd chrómovaná oceľ
Vodiace puzdro	sintrovaný bronz
Tesnenia	polyuretán

N	I	M	K	32 / 80
				PRIEMER
				32
				40
				50
				63
				ZDVIH
				25
				50
				80
				100
				125
				160
				200
				250
				320
				400
				500
				600
				700
				800
				900
				1000
			VERZIE	
			K FPM tesnenie stierača	
			V FPM tesnenie	
	VERZIE			
	I Dvojčinný valec			
	D Dvojčinný valec, nastaviteľné tlmenie			
	B Dvojčinný valec, vysunutá piestnica			

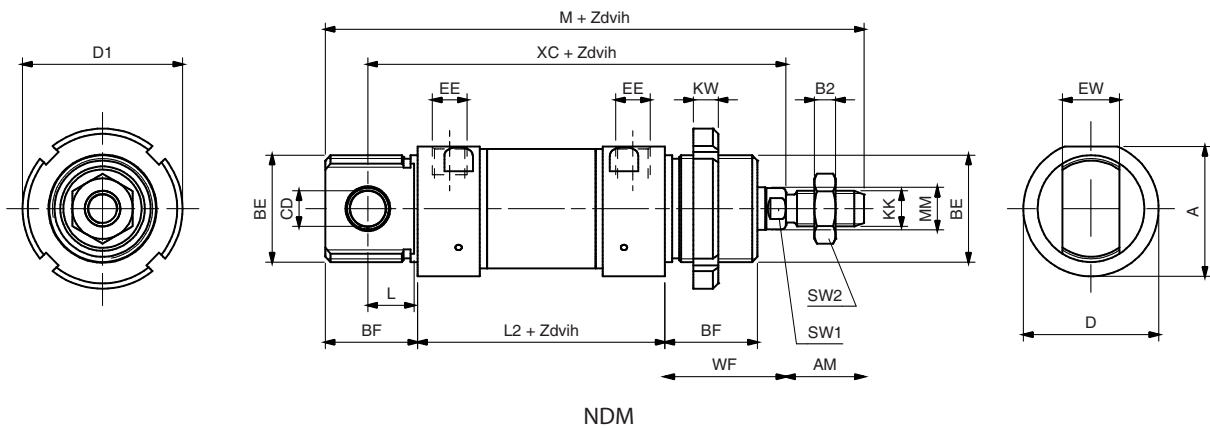
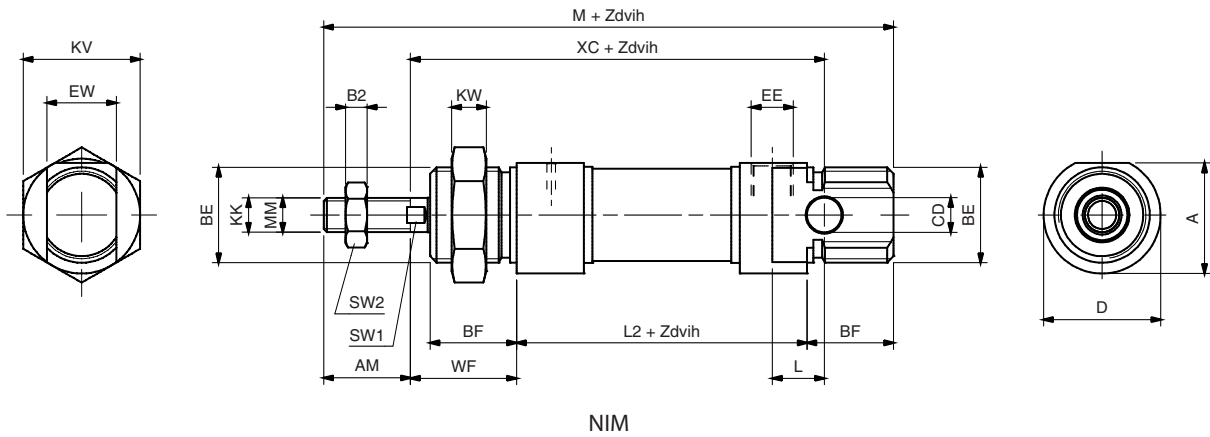
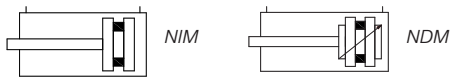

Ø [mm]	A	AM	B2	BE	BF	ØCD	ØD	ØD1	EE	EW
Ø 32	36,5	22	6	M30x1,5	26	10	38	45	G1/8"	16
Ø 40	44	24	7	M38x1,5	30	12	46	50	G1/4"	18
Ø 50	55	32	8	M45x1,5	33	16	57	58	G1/4"	21
Ø 63	67,5	32	8	M45x1,5	33	16	70	58	G3/8"	21

Ø [mm]	KK	KW	L	L2	M	ØMM	SW1	SW2	WF	XC ± 1
Ø 32	M10x1,25	7	13	69,5	151,5	12	10	17	34	117,5
Ø 40	M12x1,25	8	15	84,6	177,6	16	13	19	39	139,6
Ø 50	M16x1,5	9	16	86,2	195,2	20	17	24	44	147,2
Ø 63	M16x1,5	9	16	94,2	204,2	20	17	24	45	156,2

NBM

strana 30

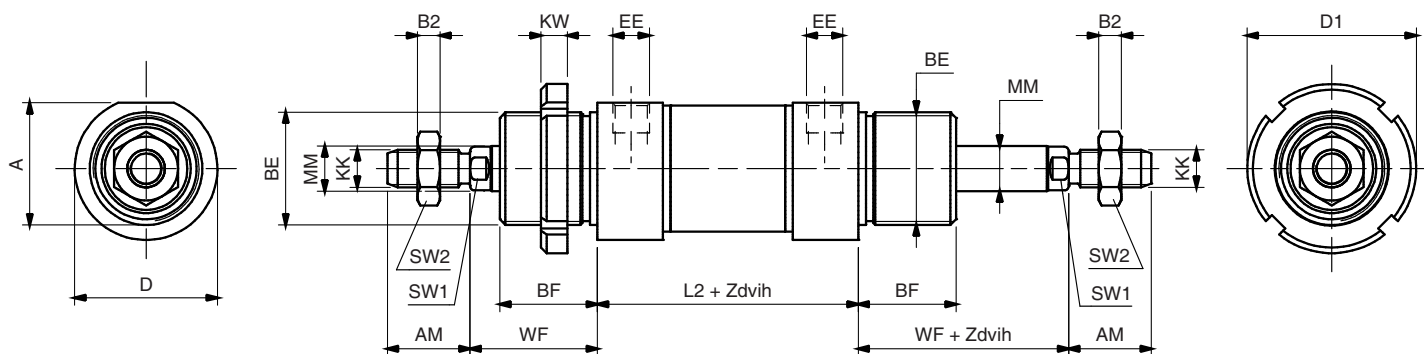
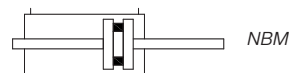

Ø [mm]	A	AM	B2	BE	BF	ØD	ØD1	EE
Ø 32	36,5	22	6	M30x1,5	26	38	45	G1/8"
Ø 40	44	24	7	M38x1,5	30	46	50	G1/4"
Ø 50	55	32	8	M45x1,5	33	57	58	G1/4"
Ø 63	67,5	32	8	M45x1,5	33	70	58	G3/8"

Ø [mm]	KK	KW	L2	ØMM	SW1	SW2	WF	WF
Ø 32	M10x1,25	7	69,5	12	10	17	33,9	33,9
Ø 40	M12x1,25	8	84,6	16	13	19	39	39
Ø 50	M16x1,5	9	86,2	20	17	24	43,9	43,9
Ø 63	M16x1,5	9	94,2	20	17	24	45	45

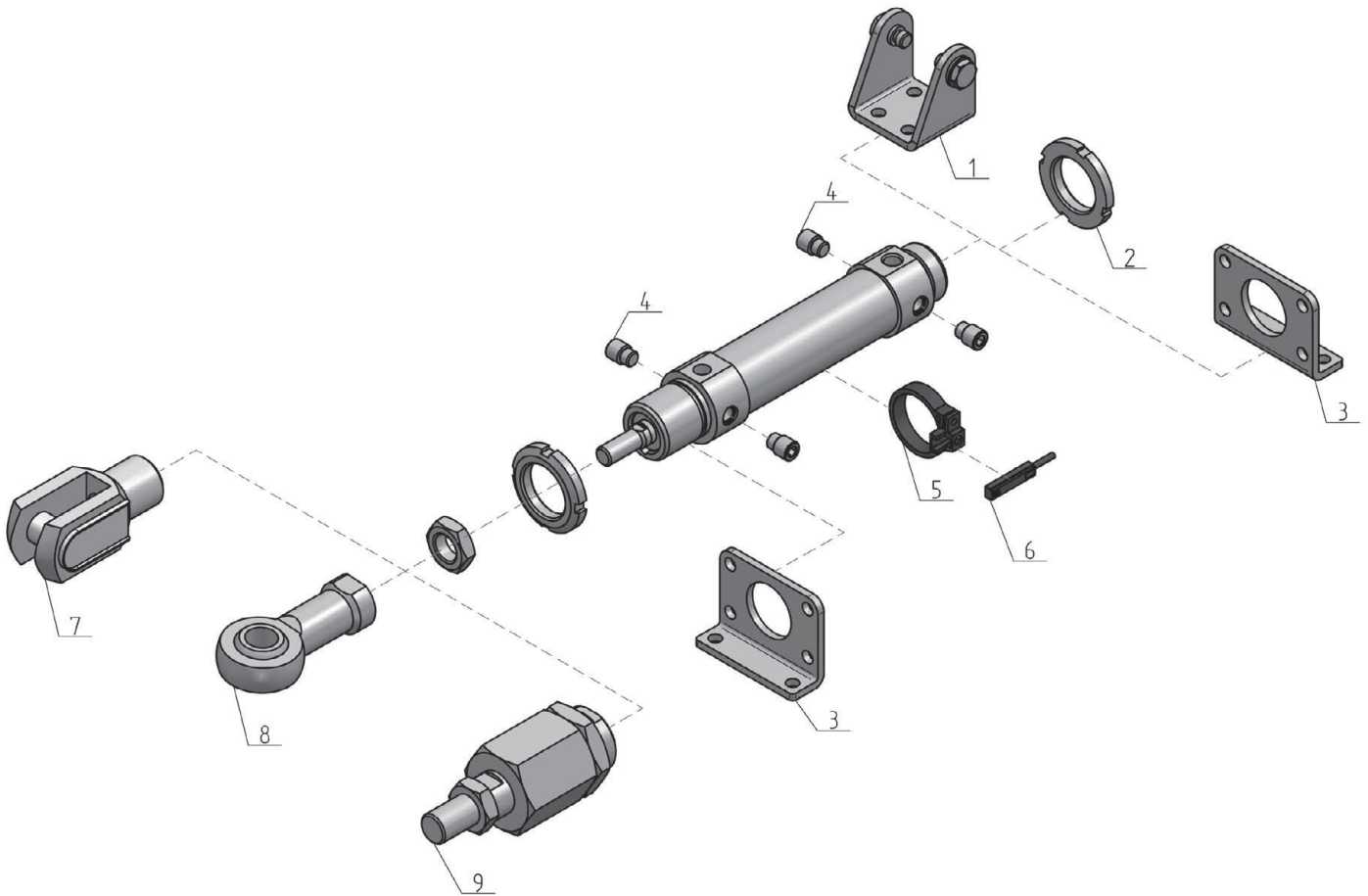

Označenie	Typ	Pomenovanie	Strana
1	ACC	Ložiskové puzdro - k valcom série A	139
2	AGT	Upevňovacia matica - k valcom série A	139
3	APD	Pätkové upevnenie - k valcom série A	140
4	APE	Výkyvný čap - k valcom série A	140
5	RXP	Upevňovacia jednotka pre SKR/SKH snímač	150
6	SKR/SKH	Snímač	149
7	UV	Vidlicová koncovka s upevňovacím čapom	134
8	UK	Kĺbová hlavica	135
9	FK	Flexibilná spojka	136

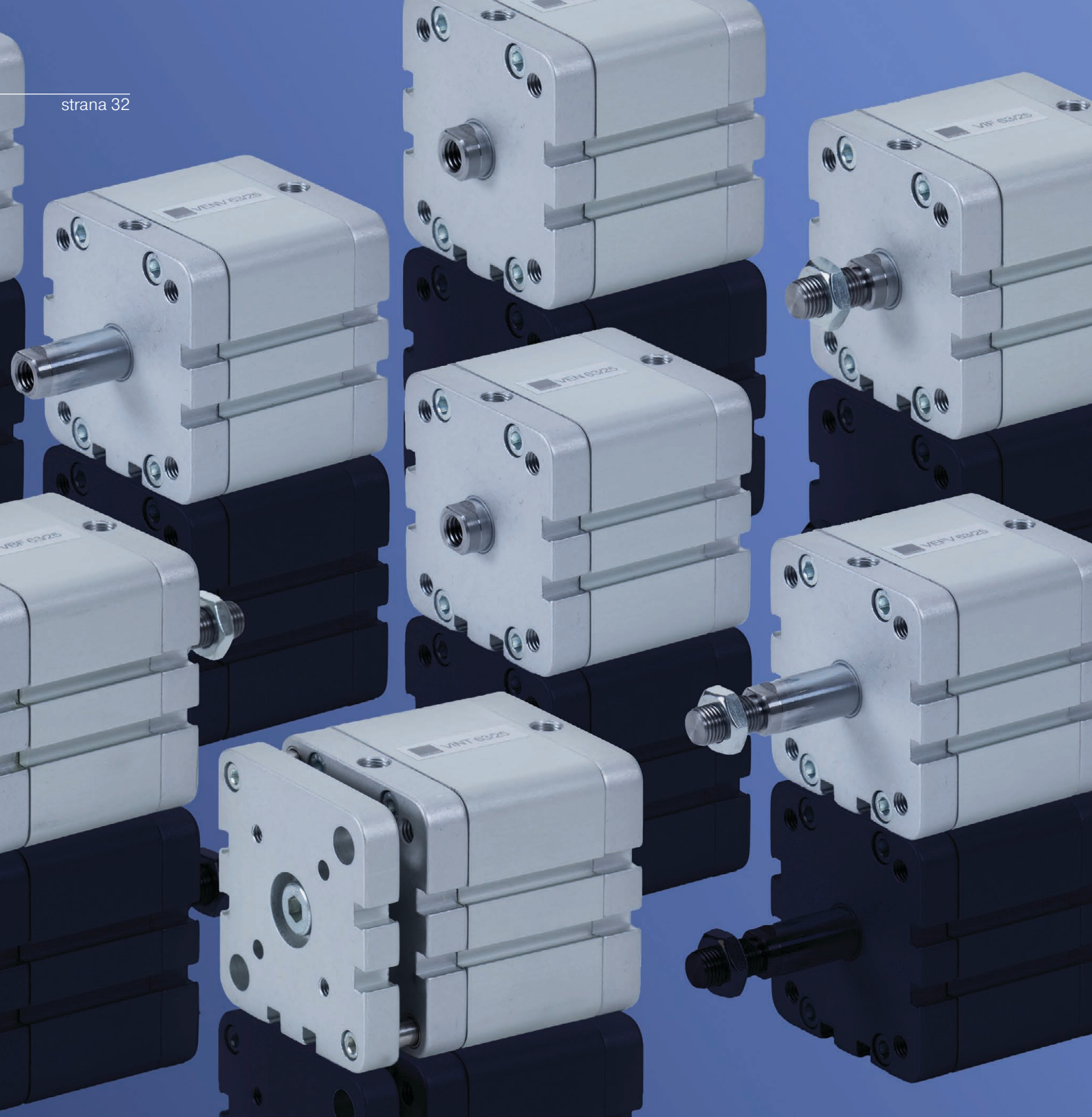

Kompaktné valce | ISO 21287

Všeobecný opis	
Priemer piestu	Ø20 - Ø25 - Ø32 - Ø40 - Ø50 - Ø63 - Ø80 - Ø100 mm
Štandardný zdvih	5- 10 - 25 - 40 - 50 - 80 - 100 - 125 - 160 - 200 - 250 - 320 - 400 mm
	Jednočinný
	Dvojčinný
Pracovné médium	stlačený vzduch
Pracovný tlak	1 ... 10 bar
Teplota okolia	-20°C ... +80°C
	0°C ... +150°C v prípade FPM tesnenia
	Pri teplotách pod 0°C je potrebné používať vhodne pripravený, suchý stlačený vzduch.
Použitý materiál	
Teleso valca	eloxovaný hliník
Kryt	eloxovaný hliník
Piest	hliník
Piestnica	tvrdá chrómovaná oceľ
Vodiace puzdro	sintovaný bronz
Tesnenia	polyuretán, NBR/FPM (v závislosti od typu)

V	I	N	V	20	/	80	Ex
				PRIEMER		ZDVIH	MOŽNOSTI
				20		5	⊕ II 2 GD c T6 -20°C < Tamb < 80°C
				25		10	
				32*		15	
				40		25	
				50		40	
				63		50	
				80		80	
				100		100	
						125	
						160	
						200	
						250	
						320	
						400	
				VERZIE			
				PRÁZDNE Štandardné tesnenie			
				K FPM tesnenie stierača			
				H FPM tesnenie (v prípade valcov VE)			
				V FPM tesnenie (v prípade valcov VI, VB, VINT)			
				VERZIE			
				NV Vysunutá piestnica s vnútorným závitom (v prípade valcov VE)			
				FV Vysunutá piestnica s vonkajším závitom (v prípade valcov VE)			
				N Piestnica s vnútorným závitom			
				F Piestnica s vonkajším závitom			
				NT S vedením zaistené proti pootočeniu (v prípade valcov VI)			
				VERZIE			
				E Jednočinný valec			
				I Dvojčinný valec			
				B Dvojčinný valec, priebežná piestnica			

* Na požiadanie dostupné aj v prevedení s dutou tyčou na vákuum

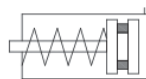

ZEN



ZIN

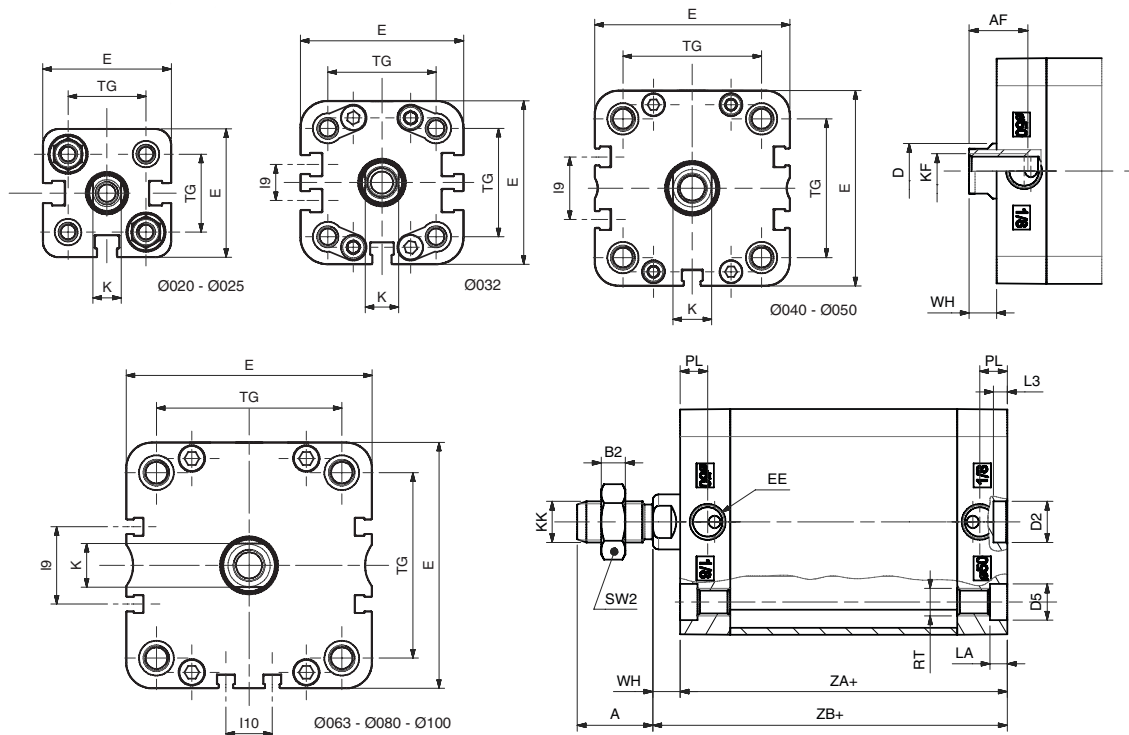

Ø [mm]	A	AF	B2	Ø D	Ø D2	Ø D5	E	EE	I9	I10	K
Ø20	16	15	5	10	9	7,5	36	M5	-	-	8
Ø25	16	15	5	10	9	7,5	40	M5	-	-	8
Ø32	19	15	6	12	9	9	49	G1/8	10,8	-	10
Ø40	19	15	6	12	9	9	54,5	G1/8	12,8	-	10
Ø50	22	17	7	16	12	10,5	65,5	G1/8	21	-	13
Ø63	22	17	7	16	12	10,5	77	G1/8	25,8	13	13
Ø80	28	20	8	20	12	13,5	95,5	G1/8	30	18	17
Ø100	28	22	8	25	12	13,5	113,5	G1/8	50	35	22

Ø [mm]	KF	KK	LA	L3	PL	RT	SW2	TG	WH	ZA+zdvih	ZB+zdvih
Ø20	M6	M8	4,5	3	7,5	M5	13	22	6,5	37	43,5
Ø25	M6	M8	4,5	3	7,5	M5	13	26	6	39	45
Ø32	M8	M10x1,25	5	3	7,5	M6	17	32,5	6,5	44	50,5
Ø40	M8	M10x1,25	5	3	8	M6	17	38	7	45	52
Ø50	M10	M12x1,25	5	4	8	M8	19	46,5	8	45	53
Ø63	M10	M12x1,25	5	4	7,5	M8	19	56,5	8	49	57
Ø80	M12	M16x1,5	3	4	8	M10	24	72	9	54	63
Ø100	M12	M16x1,5	3	4	10,5	M10	24	89	10	67	77



* ZEN valec: Ø35 - Ø40 - Ø50 - Ø60 | +10 mm v prípade Ø20 | +20 mm v prípade Ø25 - Ø32 - Ø40 | +30 mm v prípade Ø80 - Ø100



ZEF



ZIF

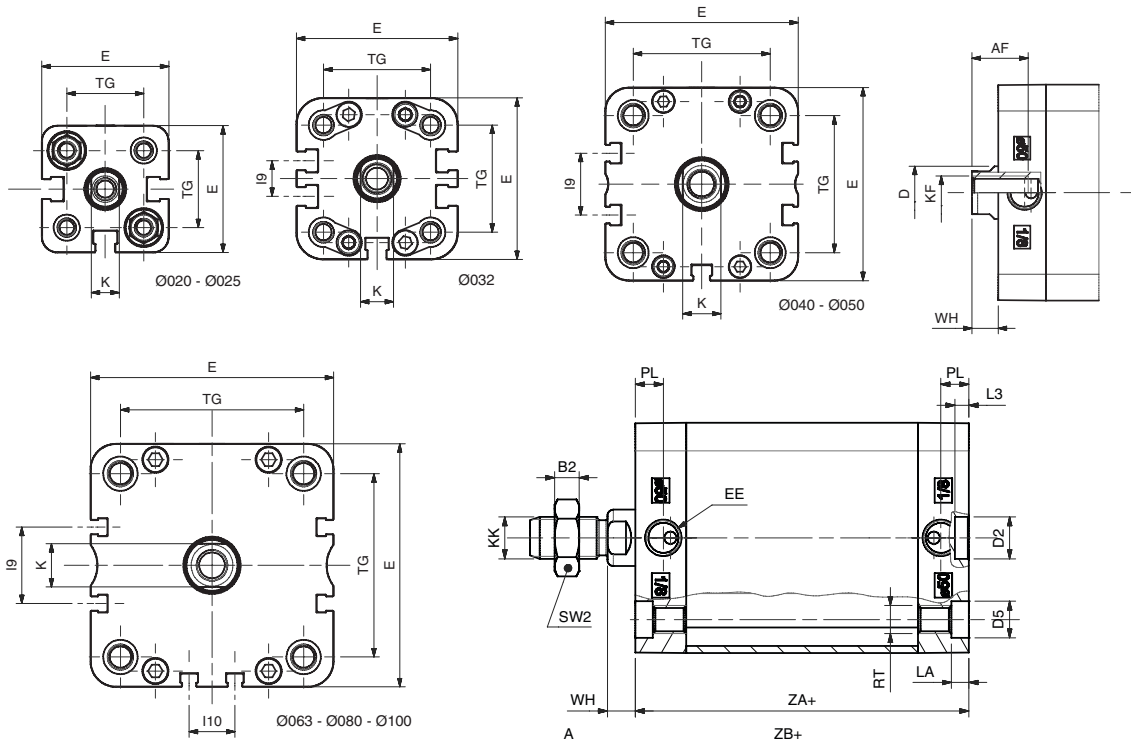
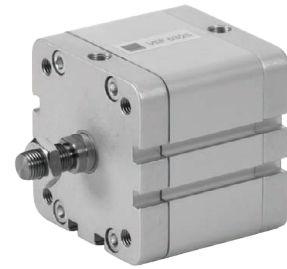

Ø [mm]	A	AF	B2	Ø D	Ø D2	Ø D5	E	EE	I9	I10	K
Ø20	16	15	5	10	9	7,5	36	M5	-	-	8
Ø25	16	15	5	10	9	7,5	40	M5	-	-	8
Ø32	19	15	6	12	9	9	49	G1/8	10,8	-	10
Ø40	19	15	6	12	9	9	54,5	G1/8	12,8	-	10
Ø50	22	17	7	16	12	10,5	65,5	G1/8	21	-	13
Ø63	22	17	7	16	12	10,5	77	G1/8	25,8	13	13
Ø80	28	20	8	20	12	13,5	95,5	G1/8	30	18	17
Ø100	28	22	8	25	12	13,5	113,5	G1/8	50	35	22

Ø [mm]	KF	KK	LA	L3	PL	RT	SW2	TG	WH	ZA+zdvih	ZB+zdvih	Ex
Ø20	M6	M8	4,5	3	7,5	M5	13	22	6,5	37	43,5	Ex
Ø25	M6	M8	4,5	3	7,5	M5	13	26	6	39	45	Ex
Ø32	M8	M10x1,25	5	3	7,5	M6	17	32,5	6,5	44	50,5	Ex
Ø40	M8	M10x1,25	5	3	8	M6	17	38	7	45	52	Ex
Ø50	M10	M12x1,25	5	4	8	M8	19	46,5	8	45	53	Ex
Ø63	M10	M12x1,25	5	4	7,5	M8	19	56,5	8	49	57	Ex
Ø80	M12	M16x1,5	3	4	8	M10	24	72	9	54	63	Ex
Ø100	M12	M16x1,5	3	4	10,5	M10	24	89	10	67	77	Ex

* Ø35- Ø40 - Ø50 - Ø60 | +10 mm v prípade Ø20 | +20 mm v prípade Ø25-32-40-50-63
+30 mm v prípade Ø80 - Ø100

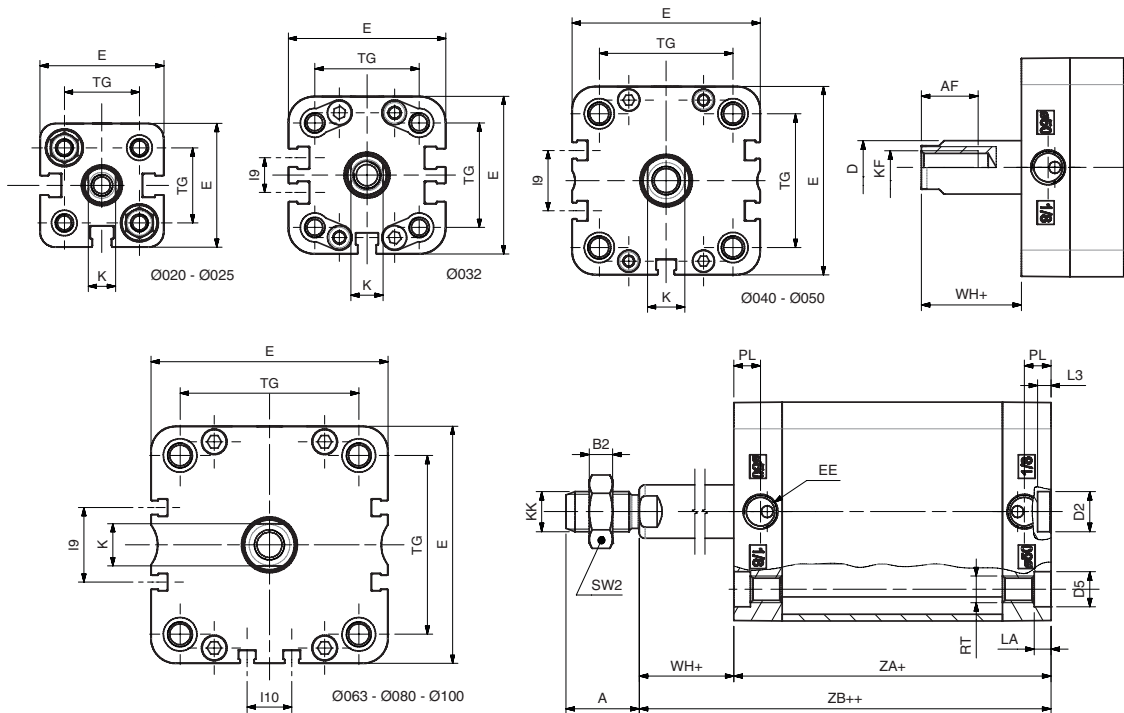
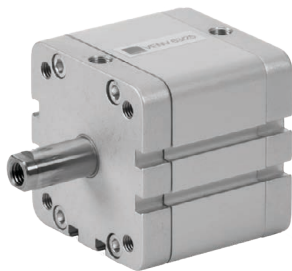

Ø [mm]	A	AF	B2	Ø D	Ø D2	Ø D5	E	EE	I9	I10	K
Ø20	16	15	5	10	9	7,5	36	M5	-	-	8
Ø25	16	15	5	10	9	7,5	40	M5	-	-	8
Ø32	19	15	6	12	9	9	49	G1/8	10,8	-	10
Ø40	19	15	6	12	9	9	54,5	G1/8	12,8	-	10
Ø50	22	17	7	16	12	10,5	65,5	G1/8	21	-	13
Ø63	22	17	7	16	12	10,5	77	G1/8	25,8	13	13
Ø80	28	20	8	20	12	13,5	95,5	G1/8	30	18	17
Ø100	28	22	8	25	12	13,5	113,5	G1/8	50	35	22

Ø [mm]	KF	KK	LA	L3	PL	RT	SW2	TG	WH+	ZA+zdvih	ZB+2xzdvih	Ex
Ø20	M6	M8	4,5	3	7,5	M5	13	22	6,5	37*	43,5*	Ex
Ø25	M6	M8	4,5	3	7,5	M5	13	26	6	39*	45*	Ex
Ø32	M8	M10x1,25	5	3	7,5	M6	17	32,5	6,5	44*	50,5*	Ex
Ø40	M8	M10x1,25	5	3	8	M6	17	38	7	45*	52*	Ex
Ø50	M10	M12x1,25	5	4	8	M8	19	46,5	8	45*	53*	Ex
Ø63	M10	M12x1,25	5	4	7,5	M8	19	56,5	8	49*	57*	Ex
Ø80	M12	M16x1,5	3	4	8	M10	24	72	9	54*	63*	Ex
Ø100	M12	M16x1,5	3	4	10,5	M10	24	89	10	67*	77*	Ex

* Ø35- Ø40 - Ø50 - Ø60 esetén | +10 mm v prípade Ø20 ... Ø63 | +20 mm v prípade Ø80 - Ø100

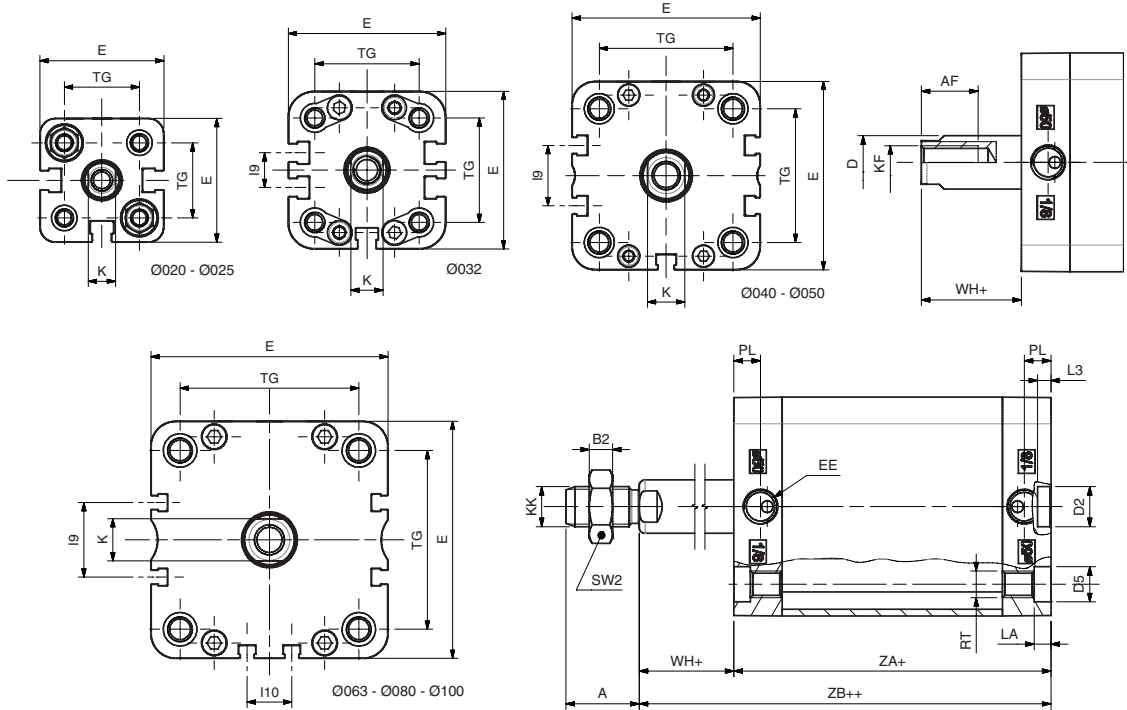
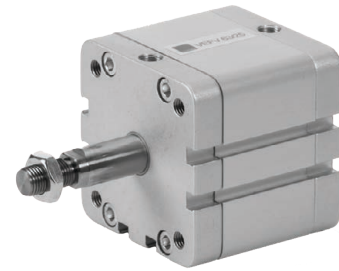
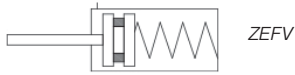

Ø [mm]	A	AF	B2	Ø D	Ø D2	Ø D5	E	EE	I9	I10	K
Ø20	16	15	5	10	9	7,5	36	M5	-	-	8
Ø25	16	15	5	10	9	7,5	40	M5	-	-	8
Ø32	19	15	6	12	9	9	49	G1/8	10,8	-	10
Ø40	19	15	6	12	9	9	54,5	G1/8	12,8	-	10
Ø50	22	17	7	16	12	10,5	65,5	G1/8	21	-	13
Ø63	22	17	7	16	12	10,5	77	G1/8	25,8	13	13
Ø80	28	20	8	20	12	13,5	95,5	G1/8	30	18	17
Ø100	28	22	8	25	12	13,5	113,5	G1/8	50	35	22

Ø [mm]	KF	KK	LA	L3	PL	RT	SW2	TG	WH+	ZA+zdvih	ZB+2xzdvih	Ex
Ø20	M6	M8	4,5	3	7,5	M5	13	22	6,5	37*	43,5*	Ex
Ø25	M6	M8	4,5	3	7,5	M5	13	26	6	39*	45*	Ex
Ø32	M8	M10x1,25	5	3	7,5	M6	17	32,5	6,5	44*	50,5*	Ex
Ø40	M8	M10x1,25	5	3	8	M6	17	38	7	45*	52*	Ex
Ø50	M10	M12x1,25	5	4	8	M8	19	46,5	8	45*	53*	Ex
Ø63	M10	M12x1,25	5	4	7,5	M8	19	56,5	8	49*	57*	Ex
Ø80	M12	M16x1,5	3	4	8	M10	24	72	9	54*	63*	Ex
Ø100	M12	M16x1,5	3	4	10,5	M10	24	89	10	67*	77*	Ex

* Ø35 - Ø40 - Ø50 - Ø60 esetén | +10 mm v prípade Ø20 ... Ø63 | +20 mm v prípade Ø80 - Ø100

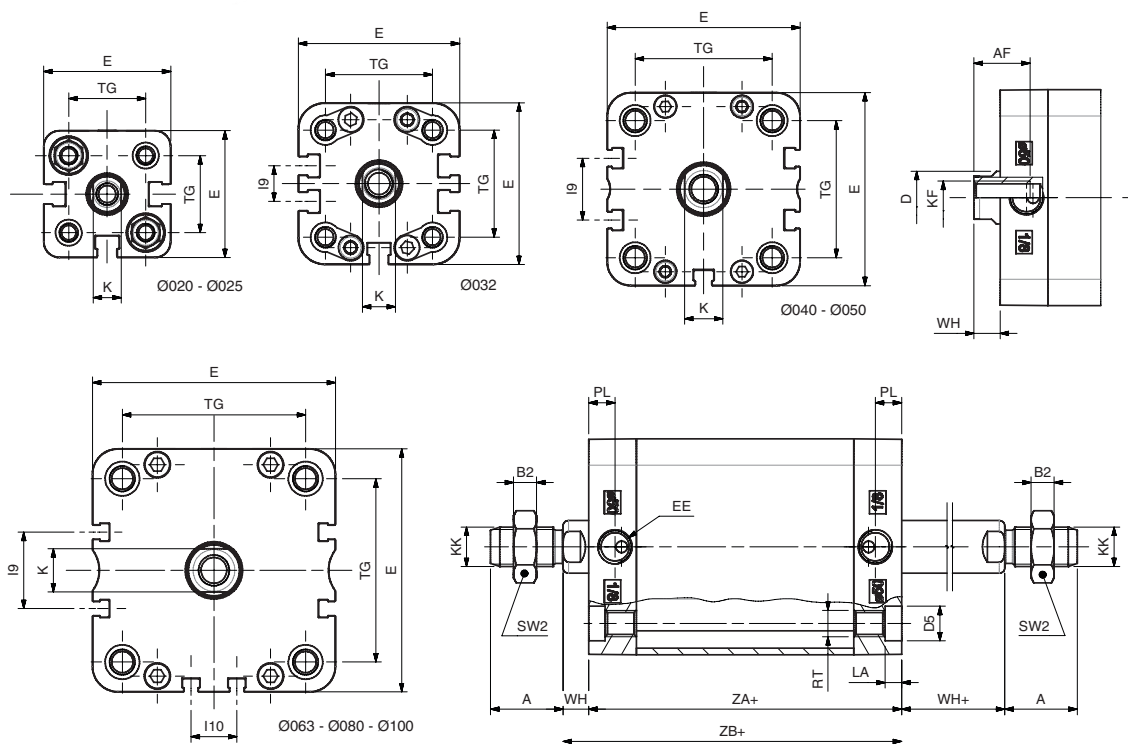
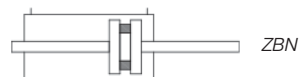
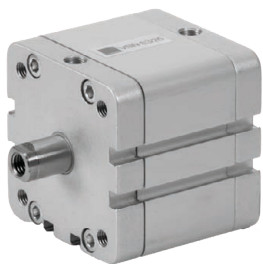

Ø [mm]	A	AF	B2	Ø D	Ø D5	E	EE	I9	I10	K
Ø20	16	15	5	10	7,5	36	M5	-	-	8
Ø25	16	15	5	10	7,5	40	M5	-	-	8
Ø32	19	15	6	12	9	49	G1/8	10,8	-	10
Ø40	19	15	6	12	9	54,5	G1/8	12,8	-	10
Ø50	22	17	7	16	10,5	65,5	G1/8	21	-	13
Ø63	22	17	7	16	10,5	77	G1/8	25,8	13	13
Ø80	28	20	8	20	13,5	95,5	G1/8	30	18	17
Ø100	28	22	8	25	13,5	113,5	G1/8	50	35	22

Ø [mm]	KF	KK	LA	PL	RT	SW2	TG	WH	WH+	ZA+zdvih	ZB+zdvih	Ex
Ø20	M6	M8	4,5	7,5	M5	13	22	6,5	6,5	37	43,5	Ex
Ø25	M6	M8	4,5	7,5	M5	13	26	6	6	39	45	Ex
Ø32	M8	M10x1,25	5	7,5	M6	17	32,5	6,5	6,5	44	50,5	Ex
Ø40	M8	M10x1,25	5	8	M6	17	38	7	7	45	52	Ex
Ø50	M10	M12x1,25	5	8	M8	19	46,5	8	8	45	53	Ex
Ø63	M10	M12x1,25	5	7,5	M8	19	56,5	8	8	49	57	Ex
Ø80	M12	M16x1,5	3	8	M10	24	72	9	9	54	63	Ex
Ø100	M12	M16x1,5	3	10,5	M10	24	89	10	10	67	77	Ex

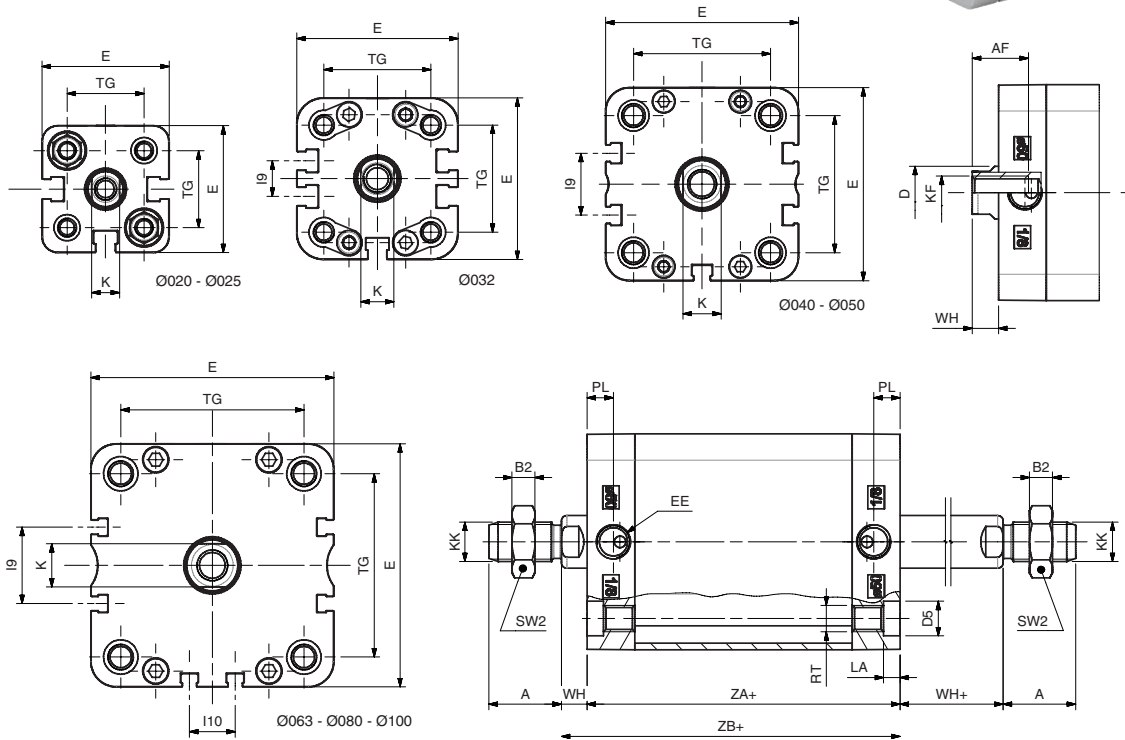
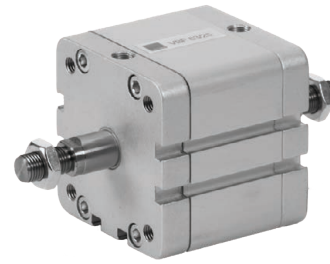
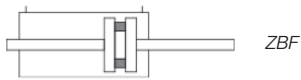

Ø [mm]	A	AF	B2	Ø D	Ø D5	E	EE	I9	I10	K
Ø20	16	15	5	10	7,5	36	M5	-	-	8
Ø25	16	15	5	10	7,5	40	M5	-	-	8
Ø32	19	15	6	12	9	49	G1/8	10,8	-	10
Ø40	19	15	6	12	9	54,5	G1/8	12,8	-	10
Ø50	22	17	7	16	10,5	65,5	G1/8	21	-	13
Ø63	22	17	7	16	10,5	77	G1/8	25,8	13	13
Ø80	28	20	8	20	13,5	95,5	G1/8	30	18	17
Ø100	28	22	8	25	13,5	113,5	G1/8	50	35	22

Ø [mm]	KF	KK	LA	PL	RT	SW2	TG	WH	WH+	ZA+zdvih	ZB+zdvih	Ex
Ø20	M6	M8	4,5	7,5	M5	13	22	6,5	6,5	37	43,5	Ex
Ø25	M6	M8	4,5	7,5	M5	13	26	6	6	39	45	Ex
Ø32	M8	M10x1,25	5	7,5	M6	17	32,5	6,5	6,5	44	50,5	Ex
Ø40	M8	M10x1,25	5	8	M6	17	38	7	7	45	52	Ex
Ø50	M10	M12x1,25	5	8	M8	19	46,5	8	8	45	53	Ex
Ø63	M10	M12x1,25	5	7,5	M8	19	56,5	8	8	49	57	Ex
Ø80	M12	M16x1,5	3	8	M10	24	72	9	9	54	63	Ex
Ø100	M12	M16x1,5	3	10,5	M10	24	89	10	10	67	77	Ex

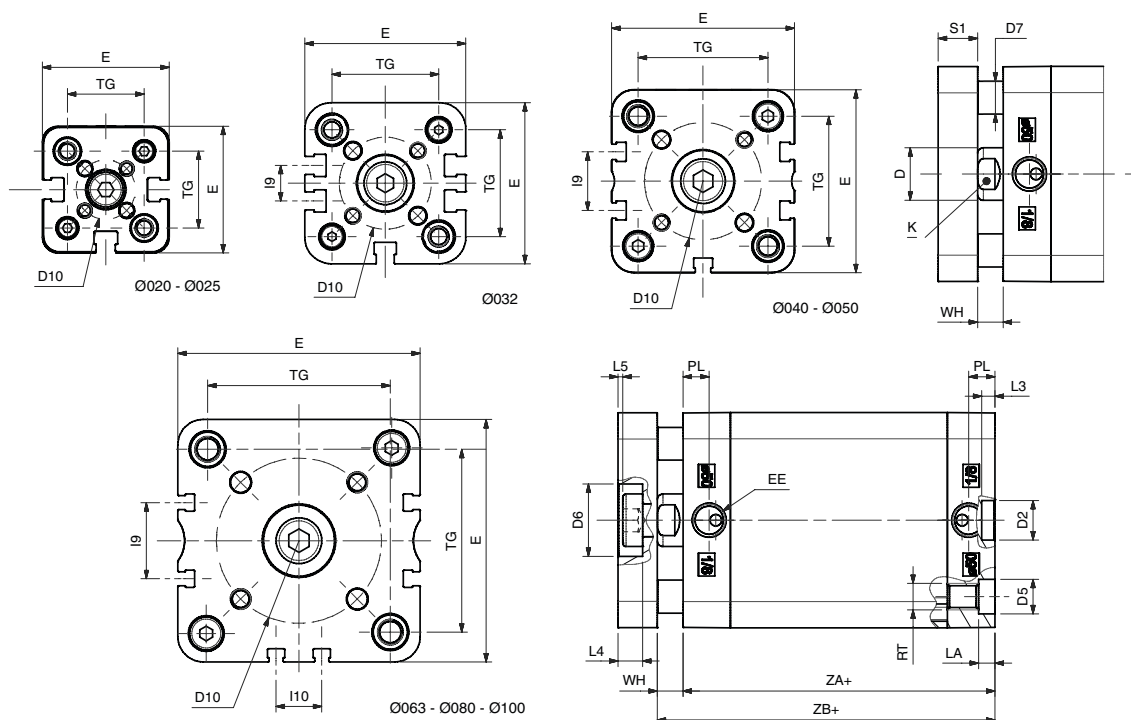
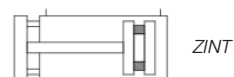

Ø [mm]	Ø D	Ø D2	Ø D5	Ø D6	Ø D7	D8	Ø D9	Ø D10	E	EE	I9	I10
Ø20	10	9	7,5	11	5	M4	4	17	36	M5	-	-
Ø25	10	9	7,5	14	6	M5	5	22	40	M5	-	-
Ø32	12	9	9	17	6	M5	5	28	49	G1/8	10,8	-
Ø40	12	9	9	17	8	M5	5	33	54,5	G1/8	12,8	-
Ø50	16	12	10,5	22	10	M6	6	42	65,5	G1/8	21	-
Ø63	16	12	10,5	22	10	M6	6	50	77	G1/8	25,8	13
Ø80	20	12	13,5	28	14	M8	8	65	95,5	G1/8	30	18

Ø [mm]	K	LA	L3	L4	L5	PL	RT	S1	TG	WH	ZA+zdvih	ZB+zdvih	Ex
Ø20	8	4,5	3	5	1	7,5	M5	8	22	6,5	37	43,5	Ex
Ø25	8	4,5	3	5	1	7,5	M5	8	26	6	39	45	Ex
Ø32	10	5	3	6,5	1,5	7,5	M6	10	32,5	6,5	44	50,5	Ex
Ø40	10	5	3	6,5	1,5	8	M6	10	38	7	45	52	Ex
Ø50	13	5	4	7,5	1,5	8	M8	12	46,5	8	45	53	Ex
Ø63	13	5	4	7,5	1,5	7,5	M8	12	56,5	8	49	57	Ex
Ø80	17	3	4	9	2	8	M10	14	72	9	54	63	Ex

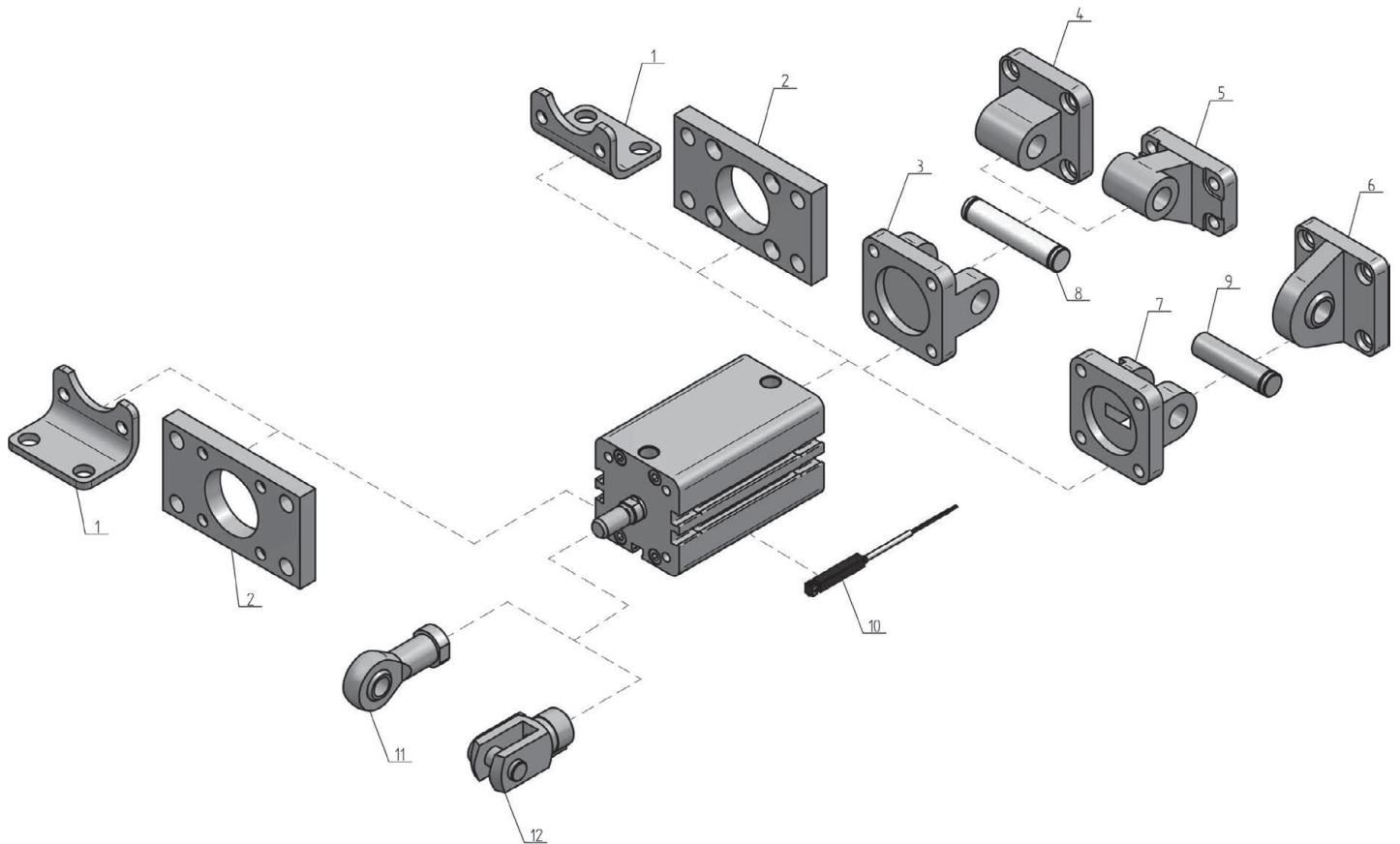

Označenie	Typ	Pomenovanie	Strana
1	DL	Pätkové upevnenie - rozmery upevnenia podľa ISO-VDMA	141
2	DF	Príruba - rozmery upevnenia podľa ISO-VDMA	140
3	DG	Vidlicová príruha - rozmery upevnenia podľa ISO-VDMA	142
4	DH	Príruba s okom - rozmery upevnenia podľa ISO-VDMA	143
5	DW	Príruba s okom (90°) - rozmery upevnenia podľa ISO-VDMA	145
6	DKL	Kĺbová príruha - rozmery upevnenia podľa ISO-VDMA	145
7	DGS	Vidlicová príruha ku kĺbovej príruhe	142
8	DC	Upínací kolík - rozmery upevnenia podľa ISO-VDMA	146
9	DCS	Upínací kolík k DGS príruhe - rozmery upevnenia podľa ISO-	146
10	SKR/SKH	Snímač	149
11	UK	Kĺbová hlavica	135
11	UKF	Kĺbová hlavica	133
12	UV	Vidlicová koncovka s upevňovacím čapom	134



Kompaktné valce | UNITOP

Všeobecný opis	
Priemer piestu	Ø12 - Ø16 - Ø20 - Ø25 - Ø32 - Ø40 - Ø50 - Ø63 - Ø80 - Ø100 mm
Štandardný zdvih	5 - 10 - 25 - 40 - 50 - 80 - 100 - 125 - 150 - 200 mm (v závislosti od priemeru)
	<div style="border: 1px solid black; padding: 2px; display: inline-block;">Jednočinný</div> <div style="border: 1px solid black; padding: 2px; display: inline-block;">Dvojčinný</div>
Pracovné médium	stlačený vzduch
Pracovný tlak	1 ... 10 bar
Teplota okolia	-20°C ... +80°C
	0°C ... +150°C v prípade FPM tesnenia
	Pri teplotách pod 0°C je potrebné používať vhodne pripravený, suchý stlačený vzduch.
Použitý materiál	
Teleso valca	eloxovaný hliník
Kryt	eloxovaný hliník
Piest	hliník
Piestnica	Ø12 ... Ø25 nehrdzavejúca oceľ / Ø32 ... Ø100 tvrdo chrómovaná oceľ
Vodiace puzdro	sintrovaný bronz
Tesnenia	polyuretán, NBR/FPM (v závislosti od typu)

Q	I	N	V	20	/	80	Ex
				PRIEMER		ZDVIH	MOŽNOSTI
				12		5	II 2 GD c T6 -20°C < Tamb < 80°C
				16		10	
				20		25	
				25		40	
				32		50	
				40		80	
				50		100	
				63		125	
				80		150	
				100		200	
				VERZIE			
				PRÁZDNE Štandardné tesnenie K FPM tesnenie stierača H FPM tesnenie (v prípade valcov QE) V FPM tesnenie (v prípade valcov QI, QB, QINT)			
				VERZIE			
				NV Vysunutá piestnica s vnútorným závitom (v prípade valcov QE) FV Vysunutá piestnica s vonkajším závitom (v prípade valcov QE) N Piestnica s vnútorným závitom F Piestnica s vonkajším závitom NT S vedením zaistené proti pootočeniu (v prípade valcov QI)			
				VERZIE			
				E Jednočinný valec I Dvojčinný valec B Dvojčinný valec, priebežná piestnica			

Valec QINTV je dostupný len od priemeru 16 mm

QEN/QIN/QBN

strana 44

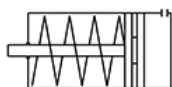
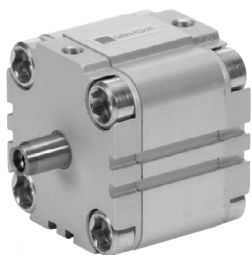

QEN



QIN

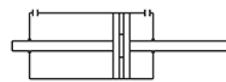

QBN

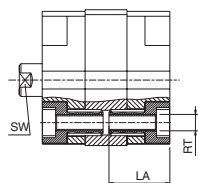
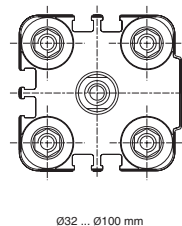
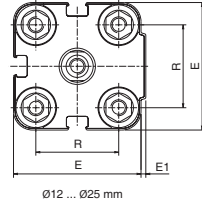
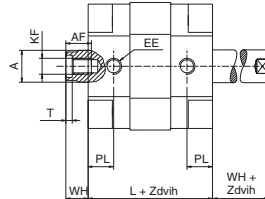
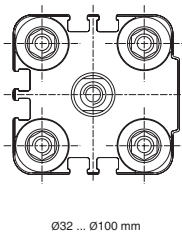
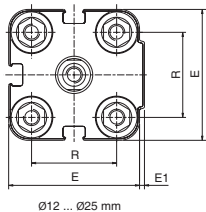
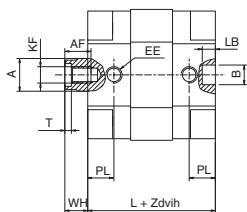

QEN/QIN

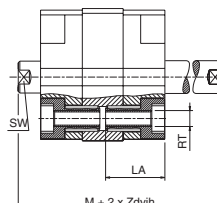

QBN

Ø [mm]	A	B	E	E1	L	M	R	T	AF
Ø 12	6	6	29	1	35 (38)*	50 (47)*	18	1,5	6
Ø 16	8	6	29	1	35 (38)*	52 (47)*	18	2	8
Ø 20	10	6	36	1,5	39 (38)*	53 (47)*	22	2	8
Ø 25	10	6	40	1,5	39 (39,5)*	53 (50,5)*	26	2	8
Ø 32	12	6	50	2	42 (44,5)*	56 (56,5)*	32	2,8	10
Ø 40	12	6	60 (58*)	2,5	45,5	62,5	42	2,8	10
Ø 50	16	6	68 (67)*	3	45,5	65,5	50	3,5	12
Ø 63	16	8	87 (80)*	4	51 (50)*	72 (65)*	62	3,5	12
Ø 80	20	8	107 (100)*	4	62 (56)*	88 (72)*	82	4,5	16
Ø 100	25	8	128 (124)*	5	68 (66,5)*	99 (86,5)*	103	6	20

Ø [mm]	EE	KF	LA	LB	PL	RT	SW	WH
Ø 12	M5	M3	16	4	6,5 (8)*	M4	5	7,5 (4,5)*
Ø 16	M5	M4	16	4	6,5 (8)*	M4	7	8,5 (4,5)*
Ø 20	M5	M5	18,5	4	8	M5	9	7 (4,5)*
Ø 25	M5	M5	18,5	4	8	M5	9	7 (5,5)*
Ø 32	G 1/8"	M6	21,5	4	6,5 (8)*	M6	10	7 (6)*
Ø 40	G 1/8"	M6	21,5	4	7,5 (8)*	M6	10	8,5 (6,5)*
Ø 50	G 1/8"	M8	23,5	4	7,5 (8)*	M8	13	10 (7,5)*
Ø 63	G 1/8"	M8	28,5	4	7,5 (8)*	M10	13	10,5 (7,5)*
Ø 80	G 1/8"	M10	28,5	4	9,5 (8,5)*	M10	17	13 (8)*
Ø 100	G 1/4"	M12	28,5	4	10,5	M10	22	15,5 (10)*

* V prípade valcov QENK, QENH, QEFK, QEFH, QENVK, QENVH, QEFVK, QEFVH, QINK, QINV, QIFK, QIFV, QBNK, QBNV, QBFK, QBFV, QINTK, QINTV

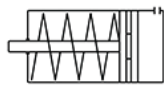

QEF

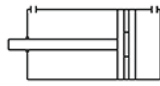

QIF

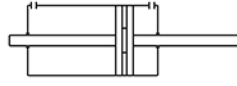

QBF

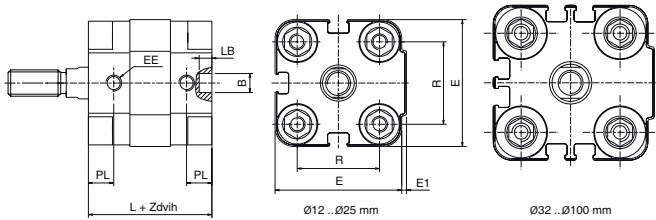
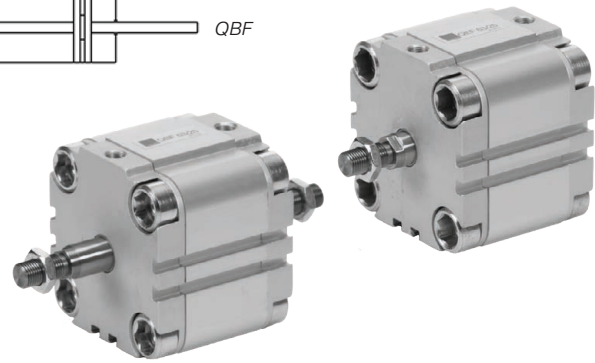

Ø12 ... Ø25 mm

Ø32 ... Ø100 mm

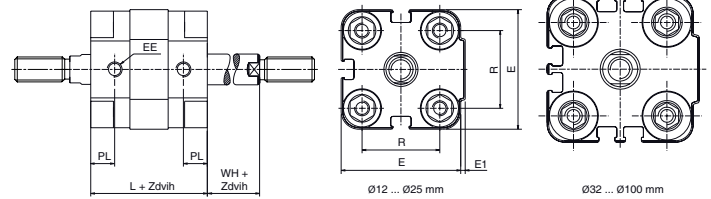

Ø12 ... Ø25 mm

Ø32 ... Ø100 mm

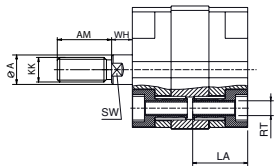

QEF/QIF

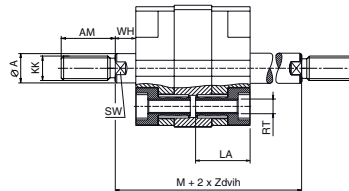

QBF

Ø [mm]	A	B	E	E1	L	M	R	T	AM
Ø 12	6	6	29	1	35 (38)*	50 (47)*	18	1,5	16
Ø 16	8	6	29	1	35 (38)*	52 (47)*	18	2	20
Ø 20	10	6	36	1,5	39 (38)*	53 (47)*	22	2	22
Ø 25	10	6	40	1,5	39 (39,5)*	53 (50,5)*	26	2	22
Ø 32	12	6	50	2	42 (44,5)*	56 (56,5)*	32	2,8	22
Ø 40	12	6	60 (58*)	2,5	45,5	62,5	42	2,8	22
Ø 50	16	6	68 (67)*	3	45,5	65,5	50	3,5	24
Ø 63	16	8	87 (80)*	4	51 (50)*	72 (65)*	62	3,5	24
Ø 80	20	8	107 (100)*	4	62 (56)*	88 (72)*	82	4,5	32
Ø 100	25	8	128 (124)*	5	68 (66,5)*	99 (86,5)*	103	6	40

Ø [mm]	EE	KK	LA	LB	PL	RT	SW	WH
Ø 12	M5	M6	16	4	6,5 (8)*	M4	5	7,5 (4,5)*
Ø 16	M5	M8	16	4	6,5 (8)*	M4	7	8,5 (4,5)*
Ø 20	M5	M10x1,25	18,5	4	8	M5	9	7 (4,5)*
Ø 25	M5	M10x1,25	18,5	4	8	M5	9	7 (5,5)*
Ø 32	G 1/8"	M10x1,25	21,5	4	6,5 (8)*	M6	10	7 (6)*
Ø 40	G 1/8"	M10x1,25	21,5	4	7,5 (8)*	M6	10	8,5 (6,5)*
Ø 50	G 1/8"	M12x1,25	23,5	4	7,5 (8)*	M8	13	10 (7,5)*
Ø 63	G 1/8"	M12x1,25	28,5	4	7,5 (8)*	M10	13	10,5 (7,5)*
Ø 80	G 1/8"	M16x1,5	28,5	4	9,5 (8,5)*	M10	17	13 (8)*
Ø 100	G 1/4"	M20x1,5	28,5	4	10,5	M10	22	15,5 (10)*

* V prípade valcov QENK, QENH, QEFK, QEFH, QENVK, QENVH, QEFVK, QEFVH, QINK, QINV, QIFK, QIFV, QBNK, QBNV, QBFK, QBFV, QINTK, QINTV

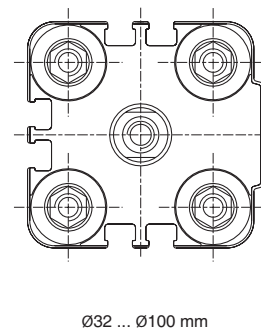
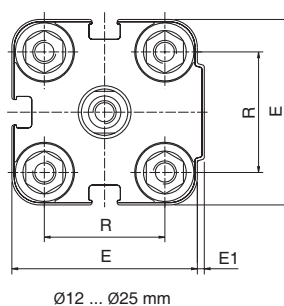
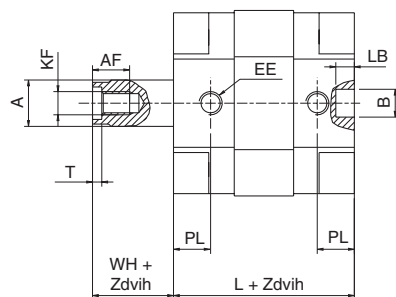
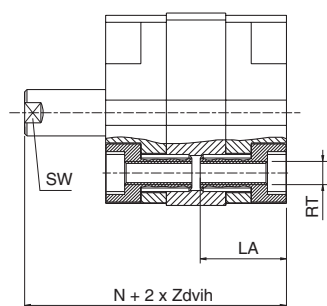
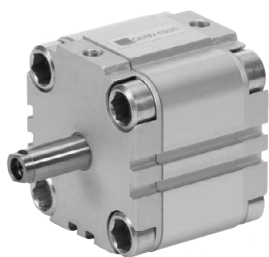

Ø [mm]	A	B	E	E1	L	N	R	T	AF
Ø 12	6	6	29	1	35 (38)*	42,5	18	1,5	6
Ø 16	8	6	29	1	35 (38)*	43,5	18	2	8
Ø 20	10	6	36	1,5	39 (38)*	46 (42,5)*	22	2	8
Ø 25	10	6	40	1,5	39 (39,5)*	46 (45)*	26	2	8
Ø 32	12	6	50	2	42(44,5)*	49 (50,5)*	32	2,8	10
Ø 40	12	6	60 (58*)	2,5	45,5	54 (52)*	42	2,8	10
Ø 50	16	6	68 (67)*	3	45,5	55,5 (53)*	50	3,5	12
Ø 63	16	8	87 (80)*	4	51 (50)*	61,5 (57,5)*	62	3,5	12
Ø 80	20	8	107 (100)*	4	62 (56)*	75 (64)*	82	4,5	16
Ø 100	25	8	128 (124)*	5	68 (66,5)*	83,5 (76,5)*	103	6	20

Ø [mm]	EE	KF	LA	LB	PL	RT	SW	WH
Ø 12	M5	M3	16	4	6,5 (8)*	M4	5	7,5 (4,5)*
Ø 16	M5	M4	16	4	6,5 (8)*	M4	7	8,5 (4,5)*
Ø 20	M5	M5	18,5	4	8	M5	9	7 (4,5)*
Ø 25	M5	M5	18,5	4	8	M5	9	7 (5,5)*
Ø 32	G 1/8"	M6	21,5	4	6,5 (8)*	M6	10	7 (6)*
Ø 40	G 1/8"	M6	21,5	4	7,5 (8)*	M6	10	8,5 (6,5)*
Ø 50	G 1/8"	M8	23,5	4	7,5 (8)*	M8	13	10 (7,5)*
Ø 63	G 1/8"	M8	28,5	4	7,5 (8)*	M10	13	10,5 (7,5)*
Ø 80	G 1/8"	M10	28,5	4	9,5 (8,5)*	M10	17	13 (8)*
Ø 100	G 1/4"	M12	28,5	4	10,5	M10	22	15,5 (10)*

* V prípade valcov QENK, QENH, QEFK, QEFH, QENVK, QENVH, QEFVK, QEFVH, QINK, QINV, QIFK, QIFV, QBNK, QBNV, QBFK, QBFV, QINTK, QINTV

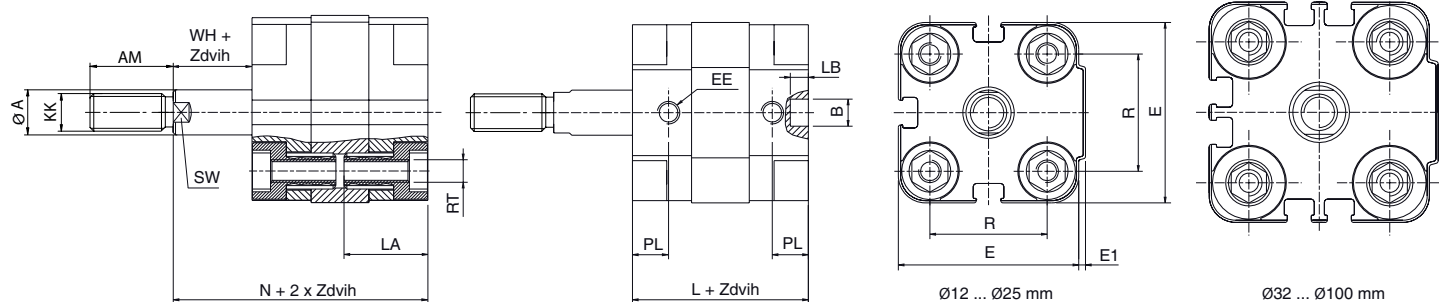
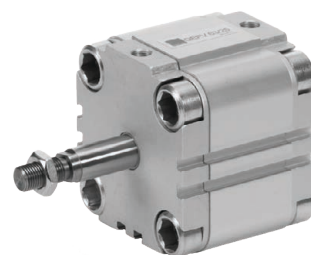

Ø [mm]	A	B	E	E1	L	N	R	T	AM
Ø 12	6	6	29	1	35 (38)*	42,5	18	1,5	16
Ø 16	8	6	29	1	35 (38)*	43,5	18	2	20
Ø 20	10	6	36	1,5	39 (38)*	46 (42,5)*	22	2	22
Ø 25	10	6	40	1,5	39 (39,5)*	46 (45)*	26	2	22
Ø 32	12	6	50	2	42(44,5)*	49 (50,5)*	32	2,8	22
Ø 40	12	6	60 (58*)	2,5	45,5	54 (52)*	42	2,8	22
Ø 50	16	6	68 (67)*	3	45,5	55,5 (53)*	50	3,5	24
Ø 63	16	8	87 (80)*	4	51 (50)*	61,5 (57,5)*	62	3,5	24
Ø 80	20	8	107 (100)*	4	62 (56)*	75 (64)*	82	4,5	32
Ø 100	25	8	128 (124)*	5	68 (66,5)*	83,5 (76,5)*	103	6	40

Ø [mm]	EE	KK	LA	LB	PL	RT	SW	WH
Ø 12	M5	M6	16	4	6,5 (8)*	M4	5	7,5 (4,5)*
Ø 16	M5	M8	16	4	6,5 (8)*	M4	7	8,5 (4,5)*
Ø 20	M5	M10x1,25	18,5	4	8	M5	9	7 (4,5)*
Ø 25	M5	M10x1,25	18,5	4	8	M5	9	7 (5,5)*
Ø 32	G 1/8"	M10x1,25	21,5	4	6,5 (8)*	M6	10	7 (6)*
Ø 40	G 1/8"	M10x1,25	21,5	4	7,5 (8)*	M6	10	8,5 (6,5)*
Ø 50	G 1/8"	M12x1,25	23,5	4	7,5 (8)*	M8	13	10 (7,5)*
Ø 63	G 1/8"	M12x1,25	28,5	4	7,5 (8)*	M10	13	10,5 (7,5)*
Ø 80	G 1/8"	M16x1,5	28,5	4	9,5 (8,5)*	M10	17	13 (8)*
Ø 100	G 1/4"	M20x1,5	28,5	4	10,5	M10	22	15,5 (10)*

* V prípade valcov QENK, QENH, QEFK, QEFH, QENVK, QENVH, QEFVK, QEFVH, QINK, QINV, QIFK, QIFV, QBNK, QBNV, QBFK, QBFV, QINTK, QINTV

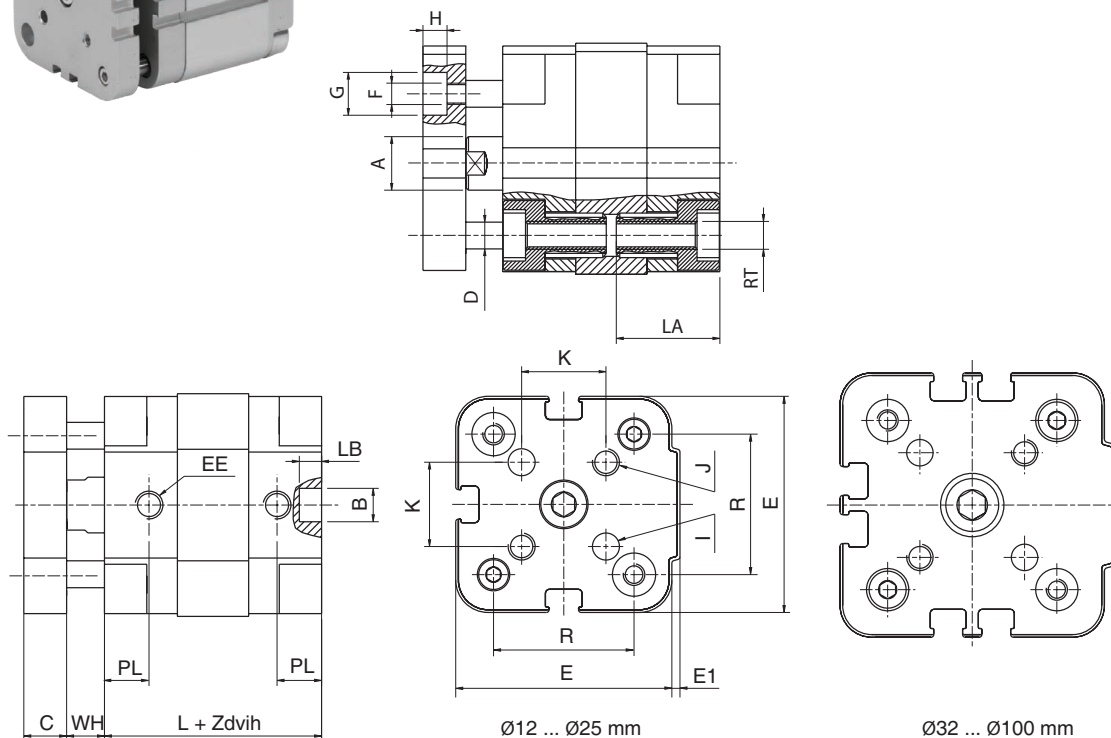
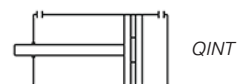

Ø [mm]	A	B	C	D	E	E1	F	G	H	I
Ø 12	6	6	5	4	29	1	M3	6	3,5	3
Ø 16	8	6	5 (6)*	4 (5)*	29	1	M3	6	3,5 (3,8)*	3
Ø 20	10	6	8 (5)*	6 (5)*	36	1,5	M3	6	3,5 (5)*	4
Ø 25	10	6	8	6	40	1,5	M4	8	4,5 (5)*	5
Ø 32	12	6	10	6 (8)*	50	2	M4	8	5,5 (6,5)*	5
Ø 40	12	6	10	6 (10)*	60	2,5	M4	8	5,5 (6,5)*	5
Ø 50	16	6	12	8 (10)*	68	3	M6	11	7 (7,5)*	6
Ø 63	16	8	12	8 (10)*	87	4	M6	11	7 (7,5)*	6
Ø 80	20	8	14	12 (14)*	107	4	M8	14	9	8
Ø 100	25	8	14	12 (14)*	128	5	M8	14	9 (10)*	10

Ø [mm]	J	K	L	R	EE	LA	LB	PL	RT	WH
Ø 12	M3	9,9	35	18	M5	16	4	6,5	M4	7,5
Ø 16	M3	9,9	35 (38)*	18	M5	16	4	6,5 (8)*	M4	8,5 (4,5)*
Ø 20	M4	12	39 (38)*	22	M5	18,5	4	8	M5	7 (4,5)*
Ø 25	M5	15,6	39 (39,5)*	26	M5	18,5	4	8	M5	7 (5,5)*
Ø 32	M5	19,8	42 (44,5)*	32	G 1/8"	21,5	4	6,5 (8)*	M6	7 (6)*
Ø 40	M5	23,3	45,5	42	G 1/8"	21,5	4	7,5 (8)*	M6	8,7 (6,5)*
Ø 50	M6	29,7	45,5	50	G 1/8"	23,5	4	7,5 (8)*	M8	10,2 (7,5)*
Ø 63	M6	35,4	51 (50)*	62	G 1/8"	28,5	4	7,5 (8)*	M10	10,5 (7,5)*
Ø 80	M8	46	62 (56)*	82	G 1/8"	28,5	4	9,5 (8,5)*	M10	12 (8)*
Ø 100	M10	56,5	68 (66,5)*	103	G 1/4"	28,5	4	10,5	M10	15,5 (10)*

Valce QINTV a QINTK sú dostupné len od priemeru 16 mm

* V prípade valcov QENK, QENH, QEFK, QEFH, QENVK, QENVH, QEFVK, QEFVH, QINK, QINV, QIFK, QIFV, QBNK, QBNV, QBFK, QBFV, QINTK, QINTV

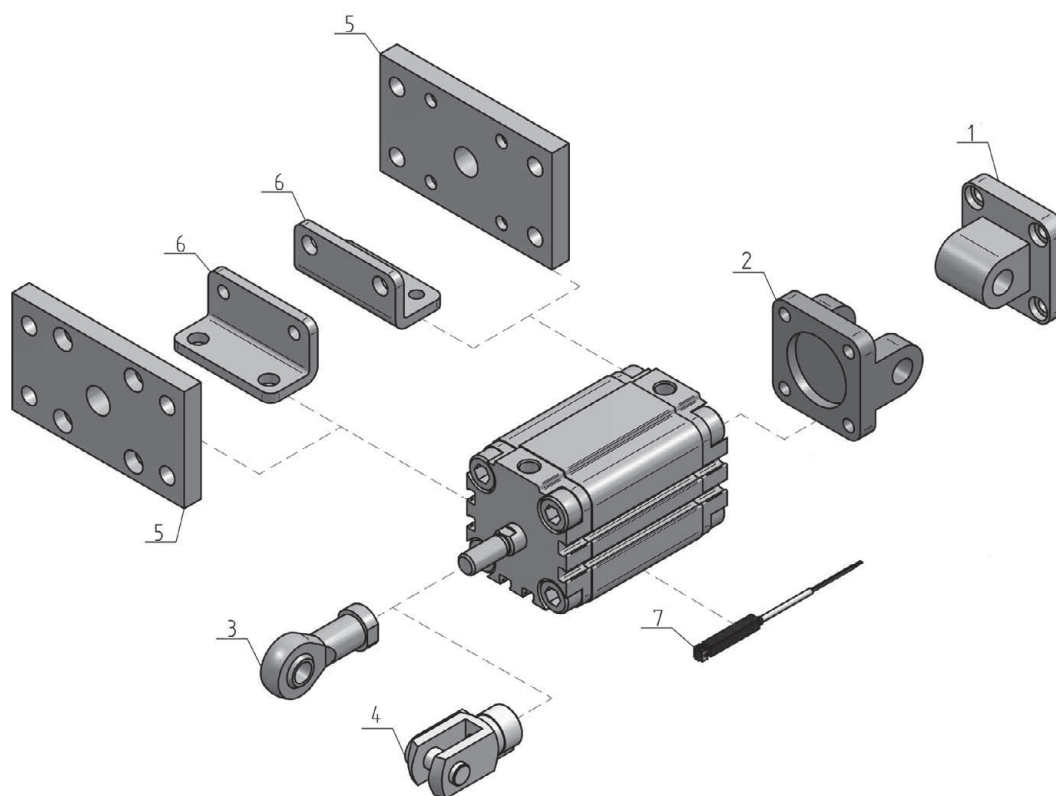

Označenie	Typ	Pomenovanie	Strana
1	QCM	Príruba s okom - UNITOP rozmery upevnenia	149
2	QCF	Vidlicová príruba - UNITOP rozmery upevnenia	148
3	UK	Kĺbová hlavica	135
3	UKF	Kĺbová hlavica	133
4	UV	Vidlicová koncovka s upevňovacím čapom	134
5	QFL	Príruba - UNITOP rozmery upevnenia	147
6	QCP	Pätkové upevnenie - UNITOP rozmery upevnenia	148
7	SKR/SKH	Snímač	149

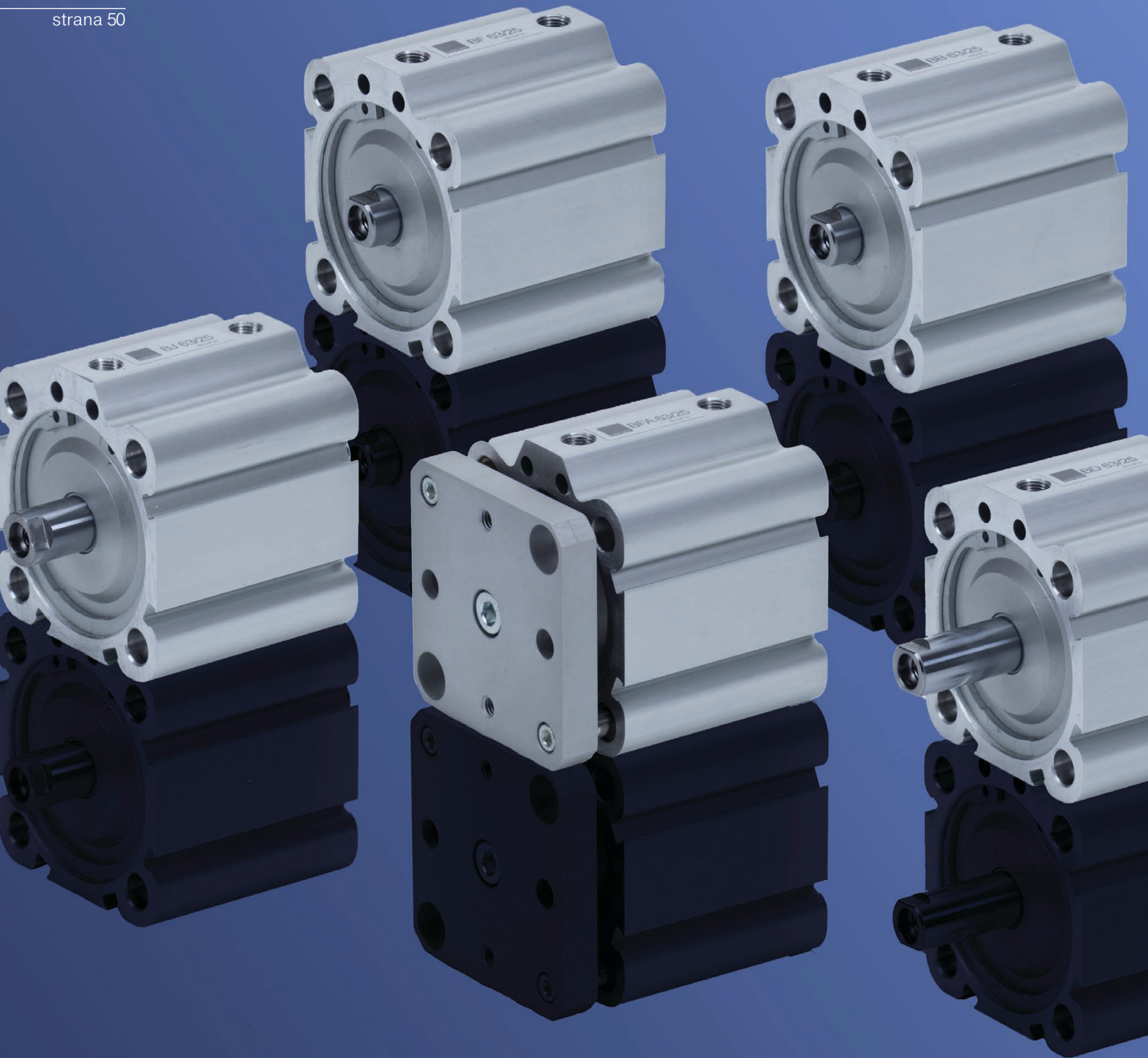

Krátkozdvihové kompaktné valce

Všeobecný opis	
Priemer piestu	Ø12 - Ø16 - Ø20 - Ø25 - Ø32 - Ø40 - Ø50 - Ø63 - Ø80 - Ø100 mm
Štandardný zdvih	5 - 10 - 15 - 20 - 25 - 30 - 40 - 50 - 75 - 80 - 100 mm (v závislosti od priemeru)
	Jednočinný
	Dvojčinný
Pracovné médium	stlačený vzduch
Pracovný tlak	1 ... 10 bar
Teplota okolia	-20°C ... +80°C
	0°C ... +150°C v prípade FPM tesnenia
Pri teplotách pod 0°C je potrebné používať vhodne pripravený, suchý stlačený vzduch.	
Použitý materiál	
Teleso valca	eloxovaný hliník
Kryt	eloxovaný hliník
Piest	hliník
Piestnica	Ø12 ... Ø25 nehrdzavejúca oceľ / Ø32 ... Ø100 tvrdo chrómovaná oceľ
Vodiace puzdro	sintrovaný bronz
Tesnenia	polyuretán, NBR/FPM (v závislosti od typu)

B	F	V	20	/	80	Ex
			PRIEMER		ZDVIH	MOŽNOSTI
			12		5	Ex S certifikátom ATEX (dostupný výlučne so štandardným tesnením)
			16		10	
			20		15	
			25		20	
			32		25	
			40		30	
			50		40	
			63		50	
			80		75	
			100		80	
					100	
VERZIE						
PRÁZDNE Štandardné tesnenie						
K FPM tesnenie stierača (v prípade valcov BF, BJ, od Ø16 mm)						
V FPM tesnenie (v prípade valcov BB, BD, BF, BJ od Ø16 mm)						
VERZIE						
B	Jednočinný valec					
D	Jednočinný valec, vysunutá piestnica					
F	Dvojčinný valec					
J	Dvojčinný valec, priebežná piestnica					
FA	S vedením zaistené proti pootočeniu					

BB/BF/BJ/BD

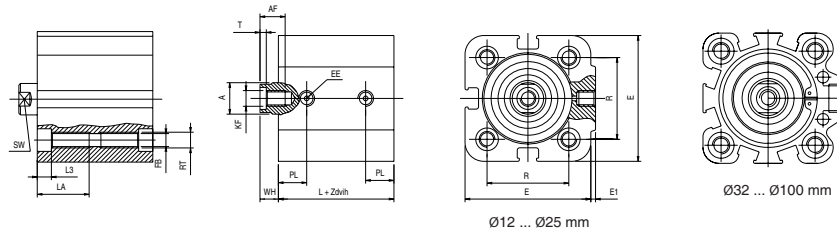
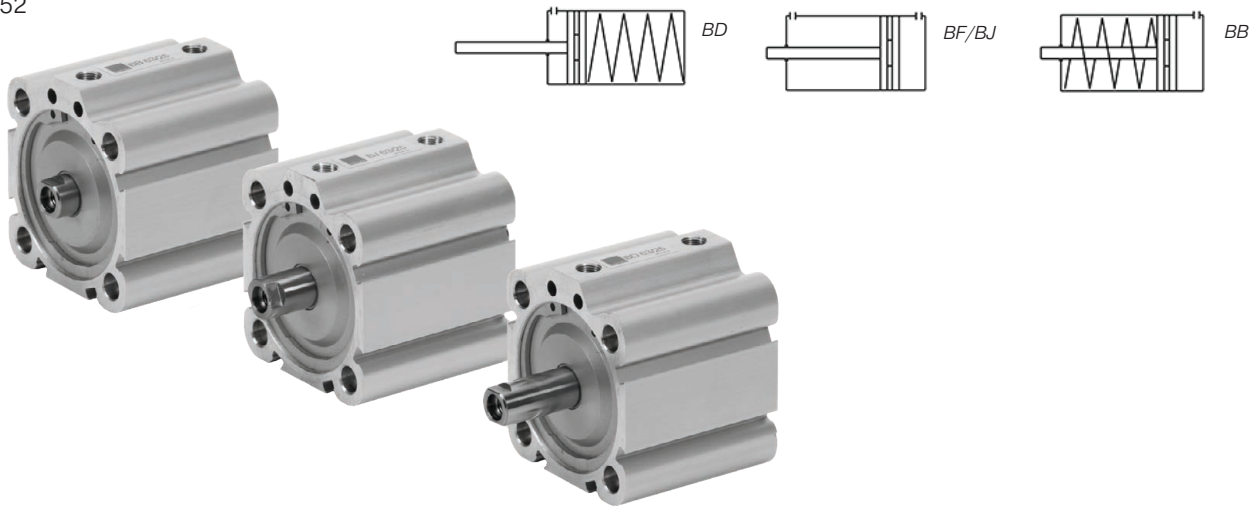

Ø12 ... Ø25 mm

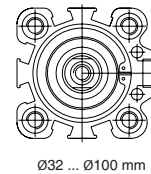

Ø32 ... Ø100 mm

BB/BF

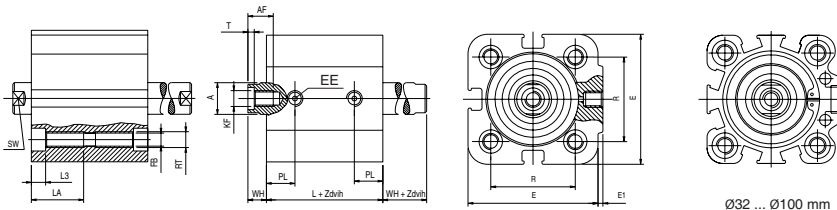

Ø12 ... Ø25 mm

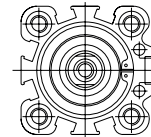

Ø32 ... Ø100 mm

BJ

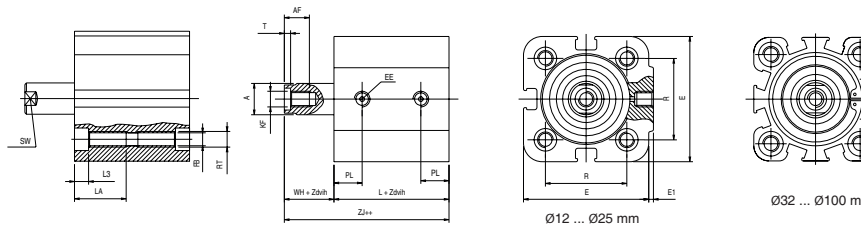

Ø12 ... Ø25 mm

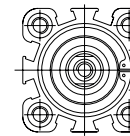

Ø32 ... Ø100 mm

BD

Ø [mm]	A	E	E1	FB	L	L3	R	T	AF	EE	KF	LA	PL	RT	SW	WH
Ø 12	6	29	1	3,3	34	3,5	18	1,5	6	M 5	M 3	12,5	7,5	M 4	5	6
Ø 16	8	29	1	3,3	36,5	3,5	18	2	8	M 5	M 4	14,5	8,5	M 4	7	6
Ø 20	10	36	1,5	4,2	37,5	4,5	22	2	8	M 5	M 5	16,5	9	M 5	9	6
Ø 25	10	40	1,5	4,2	37,5	4,5	26	2	8	M 5	M 5	16,5	9	M 5	9	6
Ø 32	12	45	3,5	5	39	5,7	32,5	2,8	10	G 1/8"	M 6	21,7	10	M 6	10	7
Ø 40	12	52	5	5	45,7	5,7	38	2,8	10	G 1/8"	M 6	21,7	11	M 6	10	7,2
Ø 50	16	63,5	7	6,8	47,5	6,8	46,5	3,5	12	G 1/8"	M 8	22,8	11	M 8	13	8,5
Ø 63	16	77	7	6,8	54	6,8	56,5	3,5	12	G 1/8"	M 8	22,8	11,5	M 8	13	8
Ø 80	20	92	10	8,5	65	9	72	4,5	16	G 1/8"	M 10	25	14	M 10	17	11
Ø 100	25	113	13	8,5	77	9	89	6	20	G 1/4"	M 12	25	17,5	M 10	22	12

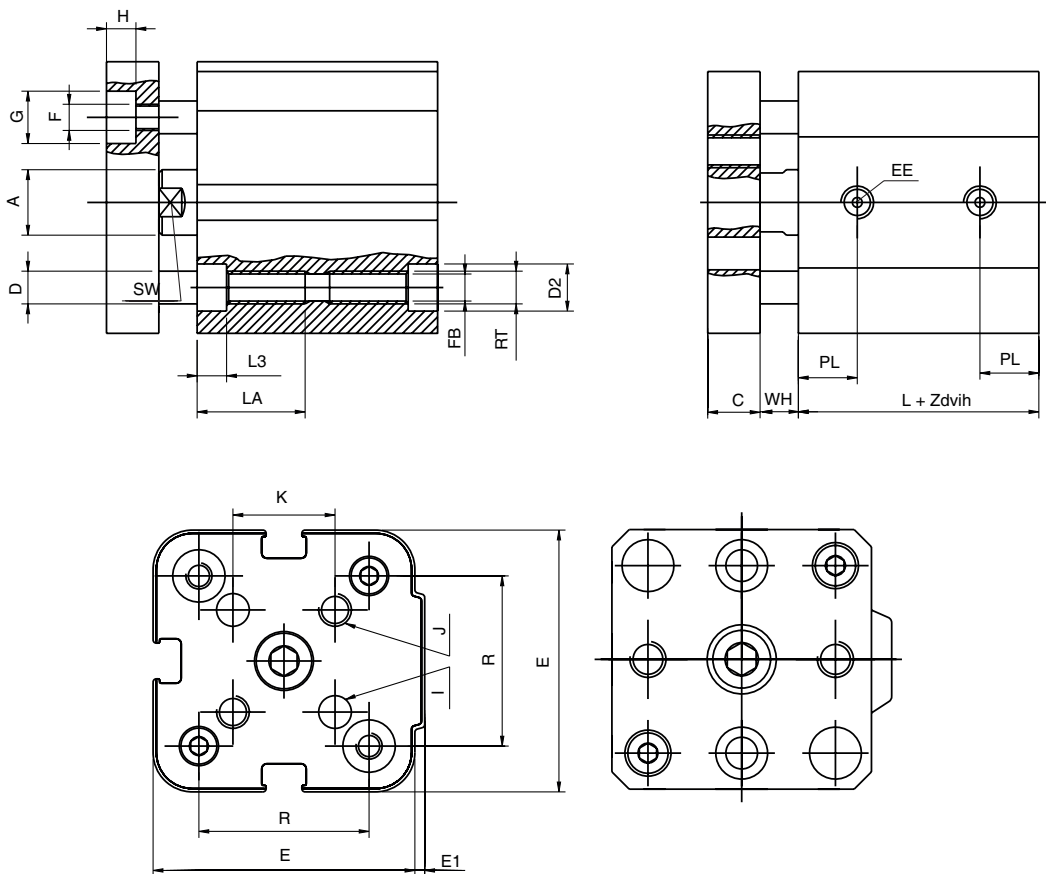
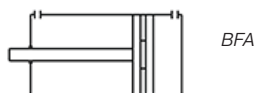

Ø [mm]	A	C	D	D2	E	E1	F	FB	G	H	I	J	K	L	L3	R	EE	LA	PL	RT	SW	WH
Ø 12	6	5	4	5,5	29	1	M3	3,5	6	3,5	3	M3	9,9	28	3,5	18	M5	12,5	7,5	M4	5	6
Ø 16	8	5	4	5,5	29	1	M3	3,5	6	3,5	3	M3	9,9	30,5	3,5	18	M5	14,5	8,5	M4	7	6
Ø 20	10	8	6	7	36	1,5	M3	4,2	6	3,5	4	M4	12	31,5	4,5	22	M5	16,5	9	M5	9	6
Ø 25	10	8	6	7	40	1,5	M4	4,2	8	4,5	5	M5	15,6	31,5	4,5	26	M5	16,5	9	M5	9	6
Ø 32	12	10	6	8,5	45	3,5	4,5	5	8	4,5	9	M5	-	32	5,7	32,5	G 1/8"	21,7	10	M6	10	7
Ø 40	12	10	6	8,5	52	5	4,5	5	8	4,5	9	M5	-	38,5	5,7	38	G 1/8"	21,7	11	M6	10	7,2
Ø 50	16	12	8	10	63,5	7	5,5	6,8	9	5,5	10	M6	-	39	6,8	46,5	G 1/8"	22,8	11	M8	13	8,5
Ø 63	16	12	8	10	77	7	5,5	6,8	9	5,5	14	M6	-	46	6,8	56,5	G 1/8"	22,8	11,5	M8	13	8
Ø 80	20	14	12	13	92	10	8,5	8,5	14	9	14	M8	-	54	9	72	G 1/8"	25	14	M10	17	11
Ø 100	25	14	12	13	113	13	8,5	8,5	14	9	17	M8	-	65	9	89	G 1/4"	25	17,5	M10	22	12

Krátkozdvihové kompaktné valce odolné voči vysokým teplotám

Všeobecný opis

Priemer piestu	Ø12 - Ø16 - Ø20 - Ø25 - Ø32 - Ø40 - Ø50 - Ø63 - Ø80 - Ø100 mm
Štandardný zdvih	5 - 10 - 15 - 25 - 30 - 40 - 50 - 60 - 80 - 100 - 125 - 160 - 200 - 250 mm
	Jednočinný
	Dvočinný
Pracovné médium	stlačený vzduch
Pracovný tlak	Jednočinný: 2 ... 10 bar Dvočinný: 1 ... 10 bar
Teplota okolia	0°C ... +150°C
	Pri teplotách pod 0°C je potrebné používať vhodne pripravený, suchý stlačený vzduch.

Použitý materiál

Teleso valca	eloxovaný hliník
Kryt	Ø12 ... Ø25 mosadz/ Ø32 ... Ø100 eloxovaný hliník
Piest	hliník
Piestnica	nehrdzavejúca oceľ AISI 303
Vodiace puzdro	oceľ + PTFE
Tesnenia	polyuretán

Krátkozdvihové kompaktné valce odolné voči vysokým teplotám

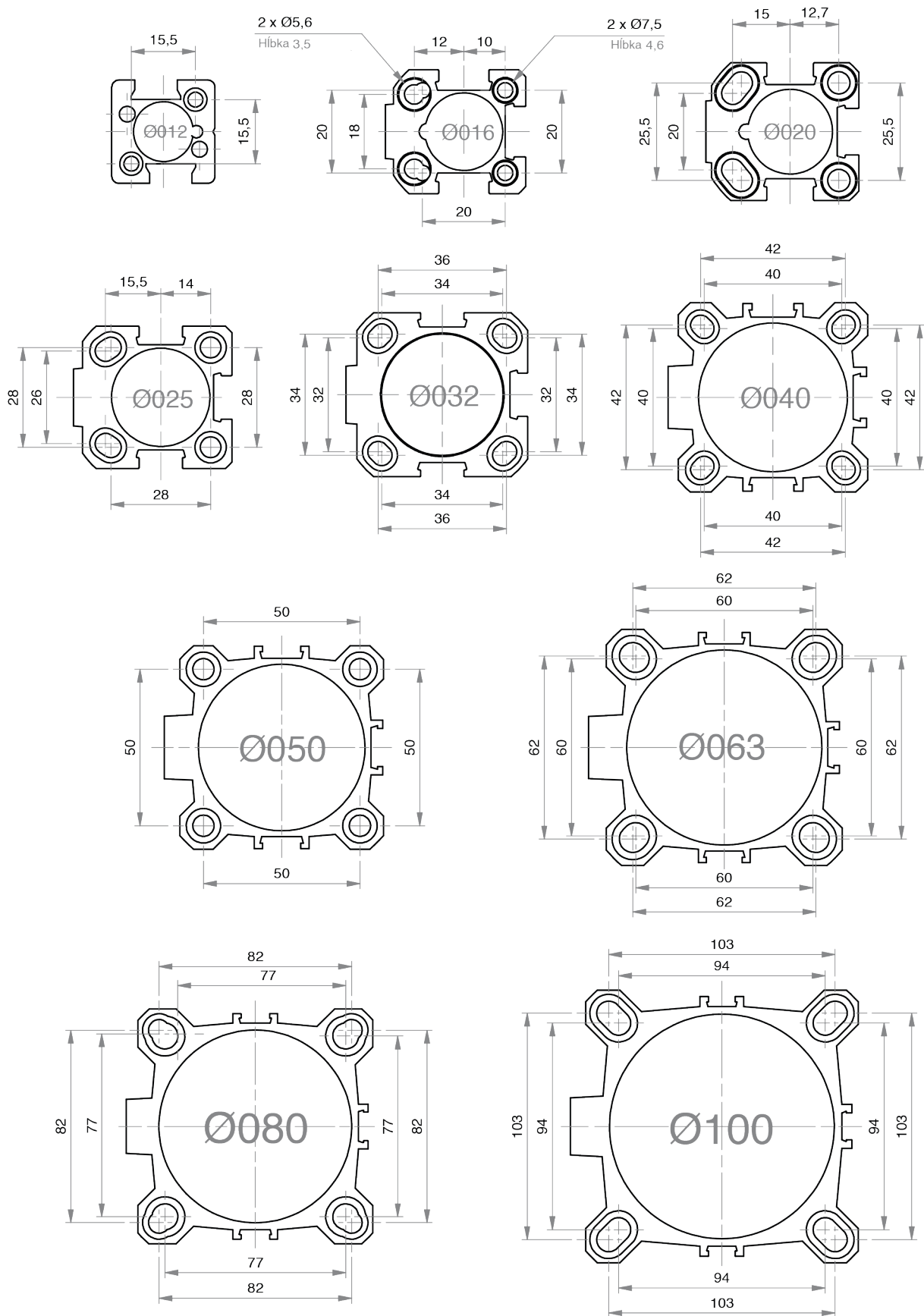

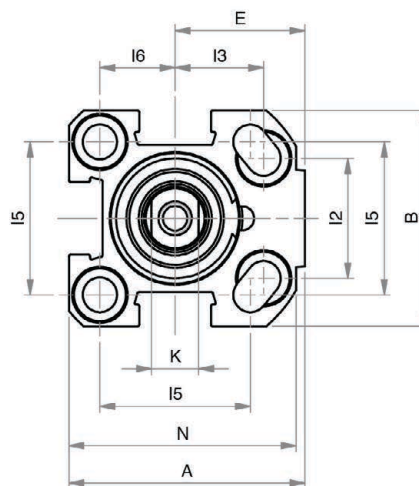
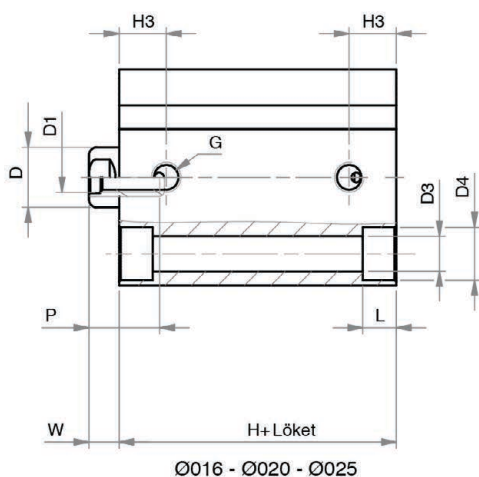
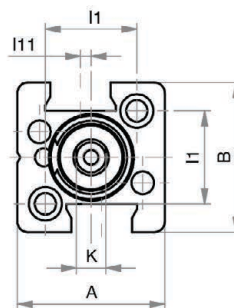
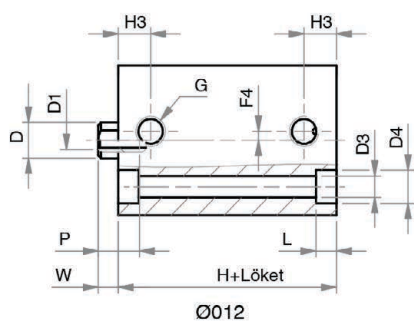
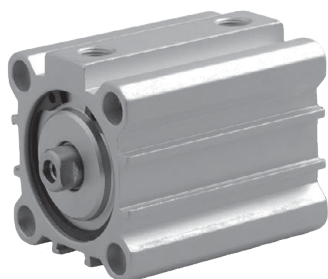

Ø [mm]	A	B	D	D1	D3	D4	E	G	H+	H3	I1
Ø12	25	25	6	M3	3,7	5,6	-	M5	27	5,5	15,5
Ø16	34	30	8	M4	**	**	19	M5	32*	8	-
Ø20	40	36	10	M5	5,8	9	22	M5	32*	8	-
Ø25	44,5	40	10	M5	5,8	9	24,5	G1/8	38,5*	10,5	-

Ø [mm]	I2	I3	I5	I6	K	L	L1	N	P	W
Ø12	-	-	-	-	5	3,5	-	-	7	3,5
Ø16	18	12	20	10	6	4,6	3,5	32	11	4,5
Ø20	20	15	25,5	12,7	8	5,7	5,7	38,5	12	4,5
Ø25	26	15,5	28	14	8	5,7	5,7	42	12	5,5

* V prípade 25 mm zdvihu: +6 mm pre Ø16-Ø20 | +1 mm pre Ø25

* V prípade 40-50 mm zdvihu: +10 mm pre Ø32-Ø40-Ø50-Ø63-Ø80-Ø100

** Vid' na strane 55

+ Prosíme, rátajte aj s pridaním dĺžky zdvihu!

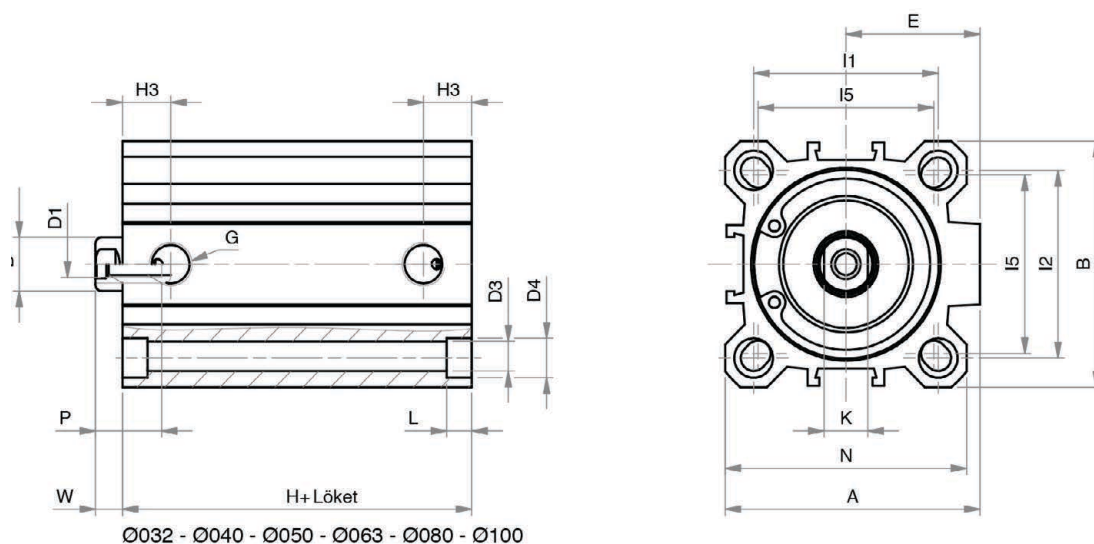

Ø [mm]	A	B	D	D1	D3	D4	E	G	H+
Ø32	51	46	12	M6	5,8	9	27	G1/8	39,5*
Ø40	58	55	12	M6	5,8	9	30,5	G1/8	39,5*
Ø50	70	65	16	M8	6,8	11	37,5	G1/8	39,5*
Ø63	89	80	16	M8	9	14	46	G1/8	42*
Ø80	105	100	20	M10	9	14	55	G1/4	46*
Ø100	131	124	25	M12	11	17,2	69	G1/4	56*

Ø [mm]	H3	I1	I2	I5	K	L	N	P	W
Ø32	11,5	36	32	34	10	5,7	48	15	5,5
Ø40	11	42	42	40	10	5,7	55	15	6,5
Ø50	11,5	50	50	50	13	6,8	65	17	7,5
Ø63	11	62	62	60	13	8,8	80	17	6,5
Ø80	14	82	82	77	17	9	100	17	8
Ø100	16	103	103	94	22	11	124	22	10

* V prípade 25 mm zdvihu: +6 mm pre Ø16-Ø20 | +1 mm pre Ø25
 * V prípade 40-50 mm zdvihu: +10 mm pre Ø32-Ø40-Ø50-Ø63-Ø80-Ø100

** Vid' na strane 55

+ Prosíme, rátajte aj s pridaním dĺžky zdvihu!

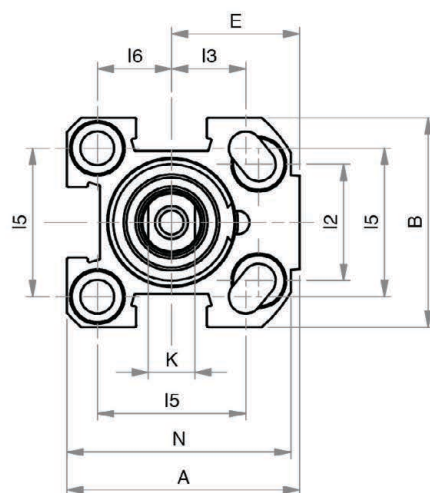
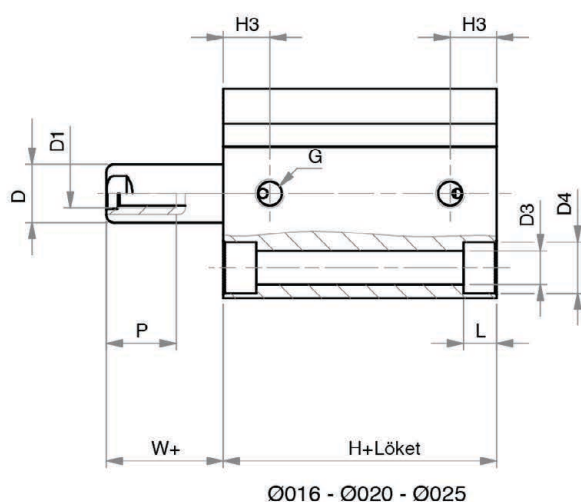
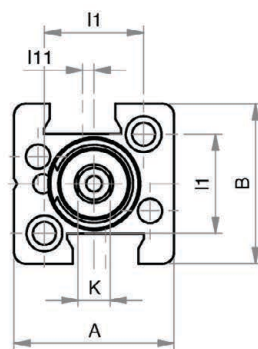
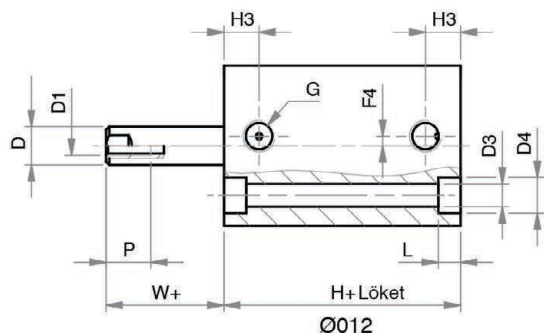
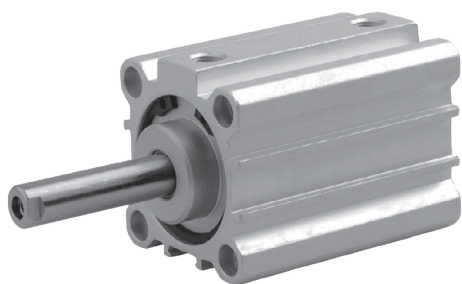

Ø [mm]	A	B	D	D1	D3	D4	E	G	H+	H3	I1
Ø12	25	25	6	M3	3,7	5,6	-	M5	***	5,5	15,5
Ø16	34	30	8	M4	**	**	19	M5	32*	8	-
Ø20	40	36	10	M5	5,8	9	22	M5	32*	8	-
Ø25	44,5	40	10	M5	5,8	9	24,5	G1/8	38,5*	10,5	-

Ø [mm]	I2	I3	I5	I6	K	L	L1	N	P	W
Ø12	-	-	-	-	5	3,5	-	-	7	3,5
Ø16	18	12	20	10	6	4,6	3,5	32	11	4,5
Ø20	20	15	25,5	12,7	8	5,7	5,7	38,5	12	4,5
Ø25	26	15,5	28	14	8	5,7	5,7	42	12	5,5

* V prípade 20-25 mm zdvihu: +11 mm pre Ø20 | +6 mm pre Ø25 | +5 mm pre Ø32

* V prípade 30 mm zdvihu: +10 mm pre Ø32

** Vid' na strane 55

+ Prosíme, rátajte aj s pridaním dĺžky zdvihu!

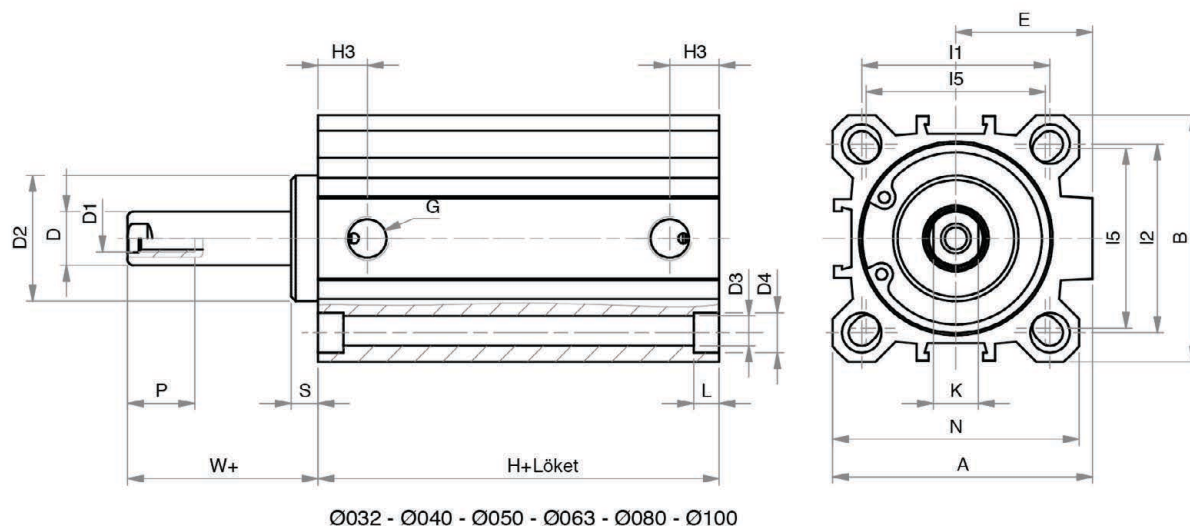

Ø032 - Ø040 - Ø050 - Ø063 - Ø080 - Ø100

Ø [mm]	A	B	D	D1	D2	D3	D4	E	G	H+
Ø32	51	46	12	M6	24,5	5,8	9	27	G1/8	39,5*
Ø40	58	55	12	M6	28	5,8	9	30,5	G1/8	39,5*
Ø50	70	65	16	M8	34	6,8	11	37,5	G1/8	39,5*
Ø63	89	80	16	M8	38,5	9	14	46	G1/8	42*

Ø [mm]	H3	I1	I2	I5	K	L	N	P	S	W
Ø32	11,5	36	32	34	10	5,7	48	15	5	5,5
Ø40	11	42	42	40	10	5,7	55	15	6	6,5
Ø50	11,5	50	50	50	13	6,8	65	17	6	7,5
Ø63	11	62	62	60	13	8,8	80	17	8	6,5

* V prípade 20-25 mm zdvihu: +11 mm pre Ø20 | +6 mm pre Ø25 | +5 mm pre Ø32

* V prípade 30 mm zdvihu: +10 mm pre Ø32

** Vid' na strane 55

+ Prosíme, rátajte aj s pridaním dĺžky zdvihu!

BFK/BFV

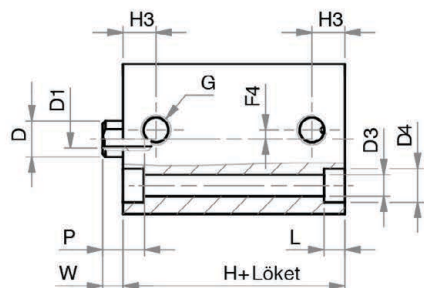
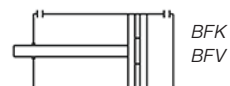
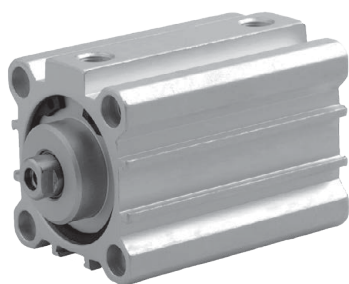

Ø12

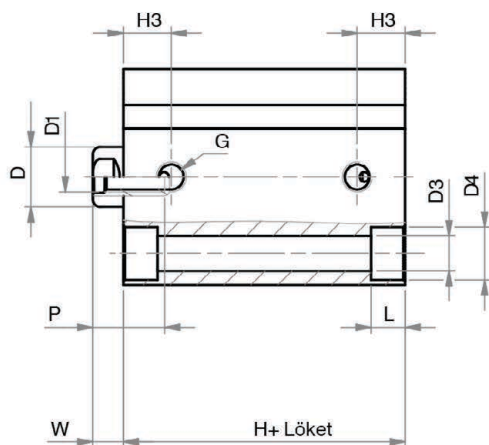
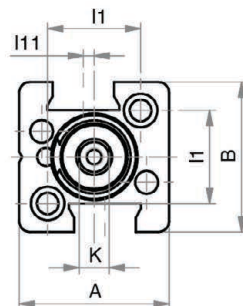

Ø16 - Ø20 - Ø25

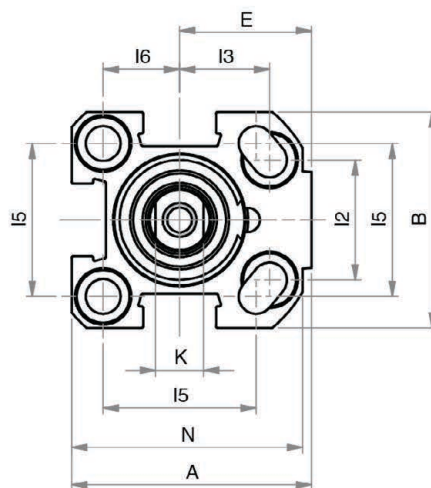

Ø [mm]	A	B	D	D1	D3	D4	E	G	H+	H3	I1
Ø12	25	25	6	M3	3,7	5,6	-	M5	27	5,5	15,5
Ø16	34	30	8	M4	**	**	19	M5	32*	8	-
Ø20	40	36	10	M5	5,8	9	22	M5	32*	8	-
Ø25	44,5	40	10	M5	5,8	9	24,5	G1/8	38,5*	10,5	-

Ø [mm]	I2	I3	I5	I6	K	L	L1	N	P	W
Ø12	-	-	-	-	5	3,5	-	-	7	3,5
Ø16	18	12	20	10	6	4,6	3,5	32	11	4,5
Ø20	20	15	25,5	12,7	8	5,7	5,7	38,5	12	4,5
Ø25	26	15,5	28	14	8	5,7	5,7	42	12	5,5

* V prípade 25 mm zdvihu: +6 mm pre Ø16-Ø20 | +1 mm pre Ø25

** Vid' na strane 55

+ Prosíme, rátajte aj s pridaním dĺžky zdvihu!

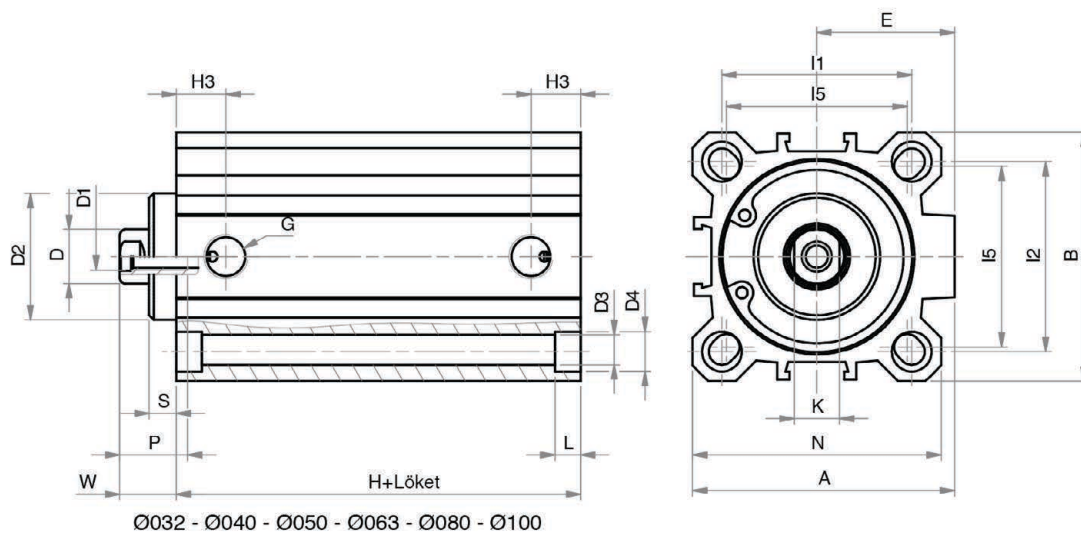

Ø [mm]	A	B	D	D1	D2	D3	D4	E	G	H+	H3
Ø32	51	46	12	M6	24,5	5,8	9	27	G1/8	39,5	11,5
Ø40	58	55	12	M6	28	5,8	9	30,5	G1/8	39,5	11
Ø50	70	65	16	M8	34	6,8	11	37,5	G1/8	39,5	11,5
Ø63	89	80	16	M8	38,5	9	14	46	G1/8	42	11
Ø80	105	100	20	M10	44	9	14	55	G1/4	46	14
Ø100	131	124	25	M12	56	11	17,2	69	G1/4	56	16

Ø [mm]	I1	I2	I5	K	L	N	P	S	W
Ø32	36	32	34	10	5,7	48	15	5	11
Ø40	42	42	40	10	5,7	55	15	6	12,5
Ø50	50	50	50	13	6,8	65	17	6	13,5
Ø63	62	62	60	13	8,8	80	17	8	15
Ø80	82	82	77	17	9	100	17	10	18
Ø100	103	103	94	22	11	124	22	10,5	20,5

+ Prosíme, rátajte aj s pridaním dĺžky zdvihu!

BJK/BJV

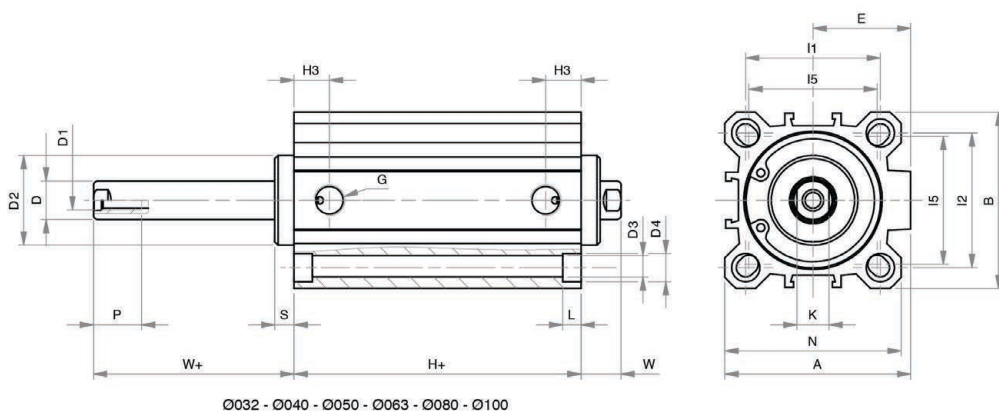
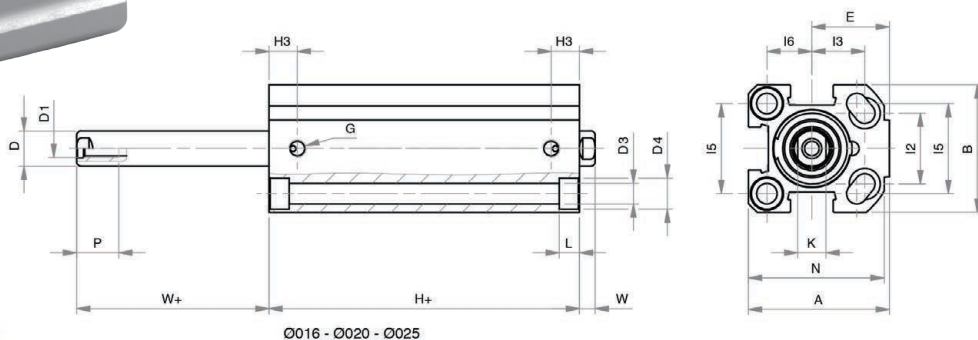
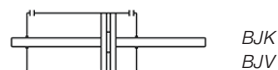
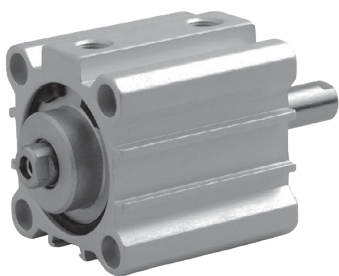

Ø [mm]	A	B	D	D1	D2	D3	D4	E	G	H+***	H3	I1
Ø16	34	30	8	M4	-	**	**	19	M5	32*	8	-
Ø20	40	36	10	M5	-	5,8	9	22	M5	32*	8	-
Ø25	44,5	40	10	M5	-	5,8	9	24,5	G1/8	38,5*	10,5	-
Ø32	51	46	12	M6	24,5	5,8	9	27	G1/8	39,5*	11,5	36
Ø40	58	55	12	M6	28	5,8	9	30,5	G1/8	39,5*	11	42
Ø50	70	65	16	M8	34	6,8	11	37,5	G1/8	39,5*	11,5	50
Ø63	89	80	16	M8	38,5	9	14	46	G1/8	42*	11	62
Ø80	105	100	20	M10	44	9	14	55	G1/4	46*	14	82
Ø100	131	124	25	M12	56	11	17,2	69	G1/4	56*	16	103

Ø [mm]	12	13	15	16	K	L	L1	N	P	S	W	W+
Ø16	18	12	20	10	6	4,6	3,5	32	11	-	4,5	4,5
Ø20	20	15	25,5	12,7	8	5,7	5,7	38,5	12	-	4,5	4,5
Ø25	26	15,5	28	14	8	5,7	5,7	42	12	-	5,5	5,5
Ø32	32	-	34	-	10	5,7	-	48	15	5	11	11
Ø40	42	-	40	-	10	5,7	-	55	15	6	12,5	12,5
Ø50	50	-	50	-	13	6,8	-	65	17	6	13,5	13,5
Ø63	62	-	60	-	13	8,8	-	80	17	8	15	15
Ø80	82	-	77	-	17	9	-	100	17	10	18	18
Ø100	103	-	94	-	22	11	-	124	22	10,5	20,5	20,5

* V prípade 25 mm zdvihu: +6 mm pre Ø16-Ø20 | +1 mm pre Ø25

** Viď na strane 55

+ Prosíme, rátajte aj s pridaním dĺžky zdvihu!

Krátkozdvihové kompaktné valce

Všeobecný opis	
Priemer piestu	Ø8 - Ø12 - Ø20 - Ø32 - Ø50 - Ø63 mm
Štandardný zdvih	4 - 5 - 10 - 15 - 20 - 25 - 30 mm <div style="margin-left: 20px;"> Jednočinný Dvočinný </div>
Pracovné médium	stlačený vzduch
Pracovný tlak	Jednočinný: 2 ... 10 bar Dvočinný: 1 ... 10 bar
Teplota okolia	-20°C ... +80°C <p>Pri teplotách pod 0°C je potrebné používať vhodne pripravený, suchý stlačený vzduch.</p>

Použitý materiál	
Teleso valca	nehodzavejúca oceľ AISI 303
Kryt	Ø8 - Ø12 - Ø20 mosadz Ø32 - Ø50 - Ø63 eloxovaný hliník
Piest	RS Ø8 - Ø12 nehrdzavejúca oceľ AISI 303 Ø20 hliník Ø32 - Ø50 - Ø63 delrin RD Ø12 - Ø20 hliník Ø32 - Ø50 - Ø63 delrin
Piestnica	eloxovaný hliník
Vodiace puzdro	oceľ + PTFE
Tesnenia	polyuretán, NBR

R	D	20	/	10
		PRIEMER	ZDVIH	
		8	RS	RD
		12	4	5
		20	5	10
		32	10	15
		50	25	20
		63		25
				30
VERZIE				
S	Jednočinný valec			
D	Dvočinný valec			

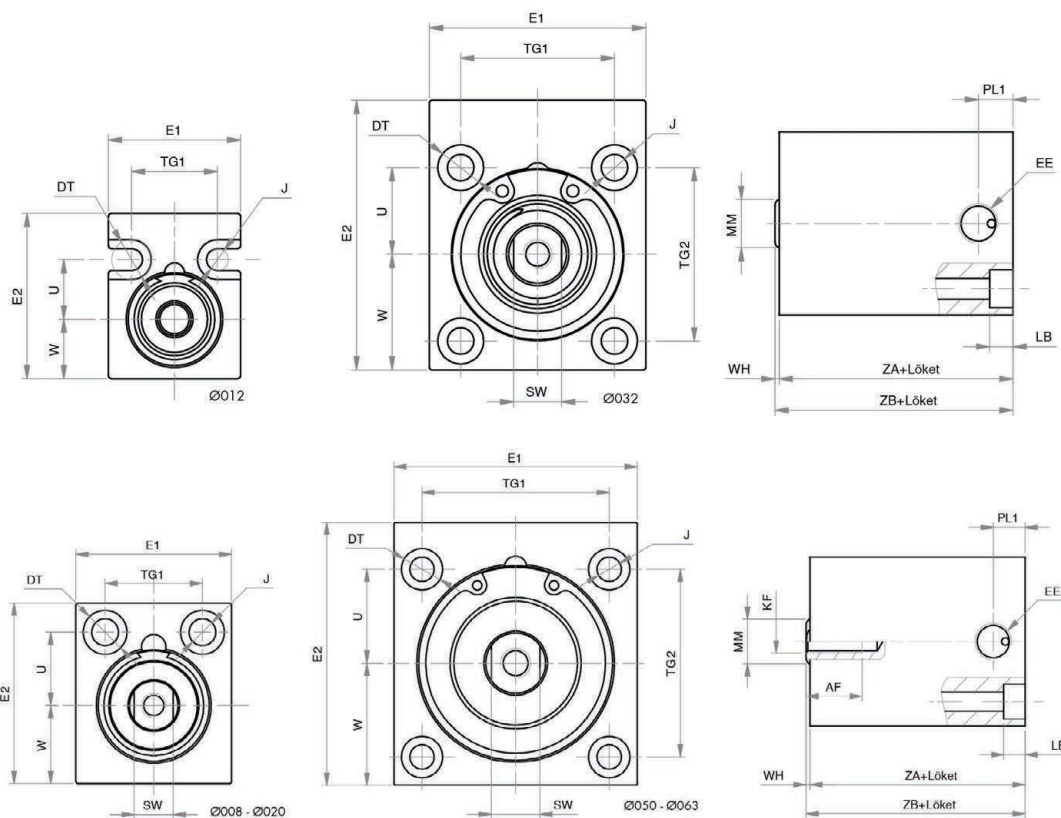
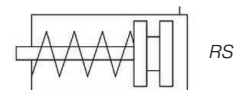

Ø [mm]	Zdvih [mm]	AF	DT	E1	E2	EE	KF	LB	MM	J	PL1	SW	TG1	TG2	U	W	WH	ZA+*	ZB+*
Ø 8	4	-	6	18	20	M5	-	3,1	4	3,4	5,5	-	11	-	8	6,5	1	12	13
Ø 12	4	-	6	20	25	M5	-	3,4	5	3,3	6	-	13	-	9	9	1	12	13
Ø 12	10	10	6	20	25	M5	M3	3,4	5	3,3	6	-	13	-	9	9	4	16	20
Ø 20	4	9	9	20	37	M5	M5	5,5	10	5,5	5	8	20	-	15	16	1	16	17
Ø 20	10	10	9	32	37	M5	M5	5,5	10	5,5	5	8	20	-	15	16	1	22	23
Ø 20	25	10	9	32	37	M5	M5	5,5	10	5,5	5	8	20	-	15	16	1	28	29
Ø 32	5	10	9,5	45	55	G1/8	M6	5,7	12	5,3	8,5	10	32	36	18	24	1	21	22
Ø 32	10	14,5	9,5	45	55	G1/8	M6	5,7	12	5,3	8,5	10	32	36	18	24	1	22	23
Ø 32	25	14,5	9,5	45	55	G1/8	M6	5,7	12	5,3	8,5	10	32	36	18	24	1	32,5	33,5
Ø 50	10	10,5	11	65	70	G1/8	M8	6,8	16	6,5	7,5	13	50	50	25	32,5	1	20	21
Ø 50	25	15,5	11	65	70	G1/8	M8	6,8	16	6,5	8	13	50	50	25	32,5	1	32,5	33,5
Ø 63	10	14,5	14	80	85	G1/8	M8	9	16	9	8	13	62	62	31	40	1	25	26
Ø 63	25	14,5	14	80	85	G1/8	M8	9	16	9	8	13	62	62	31	40	2	35,5	37,5

+ Prosíme, rátajte aj s pridaním dĺžky zdvihu!

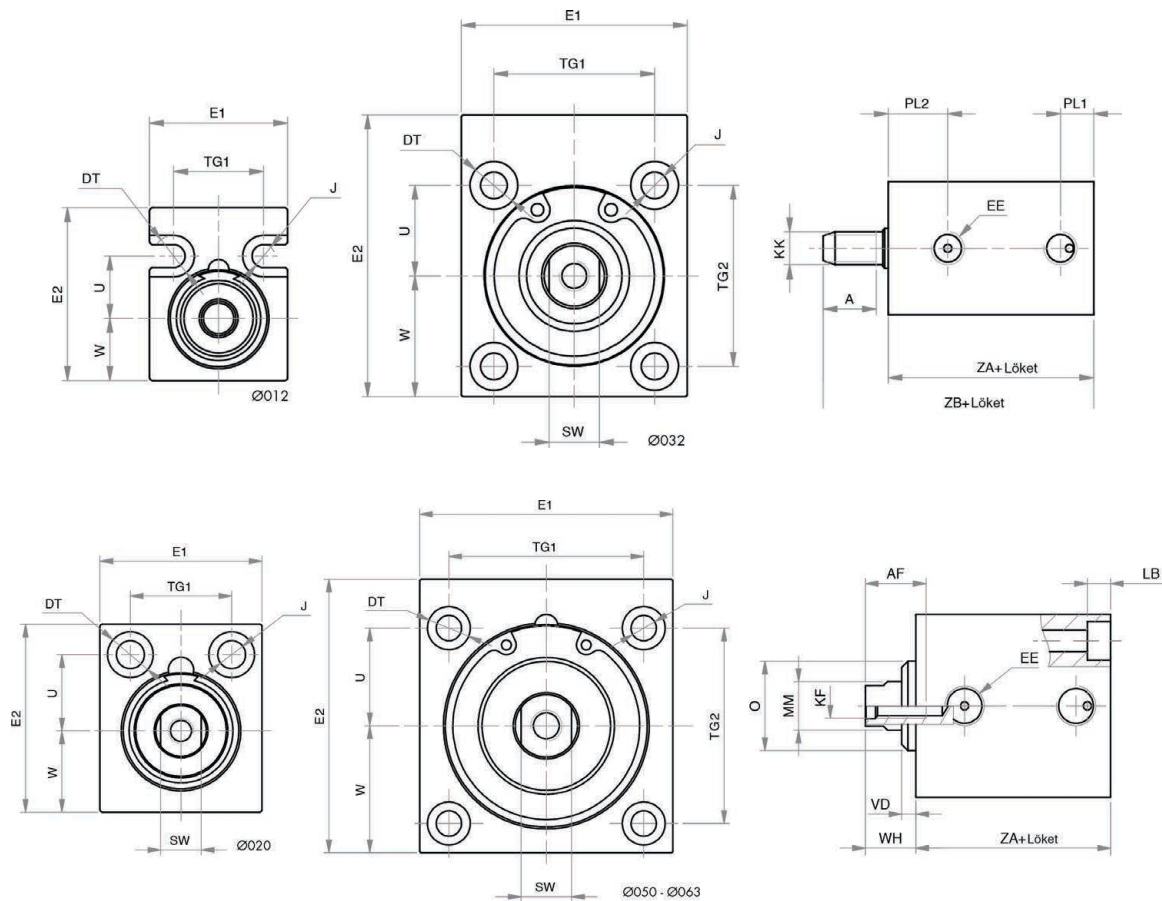
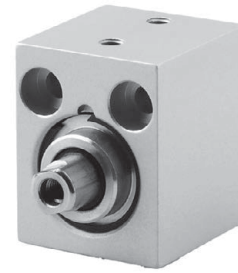
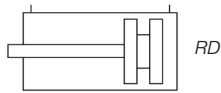

Ø [mm]	Zdvih [mm]	A	AF	DT	E1	E2	EE	KF	KK	LB	MM	J	O
Ø 12	5-10-15-20-25-30	9	-	6	20	25	M5	-	M5	3,4	6	3,3	-
Ø 20	5-10-15-20-25-30	-	10	9	32	37	M5	M5	-	5,5	10	5,5	-
Ø 32	5-10-15-20-25-30	-	15	9,5	45	56	G1/8	M6	-	5,7	12	5,3	22
Ø 50	5-10-15-20-25-30	-	17	11	65	70	G1/8	M8	-	6,8	16	6,5	35
Ø 63	5-10-15-20-25-30	-	17	14	80	85	G1/8	M8	-	9	16	9	35

Ø [mm]	Zdvih [mm]	PL1	PL2	SW	TG1	TG2	U	VD	W	WH	ZA+	ZB+
Ø 12	5-10-15-20-25-30	5	9	-	13	-	9	-	9	1	21	31
Ø 20	5-10-15-20-25-30	5	8,5	8	20	-	15	-	16	9,5	24,5	34
Ø 32	5-10-15-20-25-30	8,5	12	10	32	36	18	3,5	24	12,5	33	45,5
Ø 50	5-10-15-20-25-30	9	11	13	50	50	25	6	32,5	17	32,5	49,5
Ø 63	5-10-15-20-25-30	8	13	13	62	62	31	6,5	40	17	35,5	52,5

+ Prosíme, rátajte aj s pridaním dĺžky zdvihu!

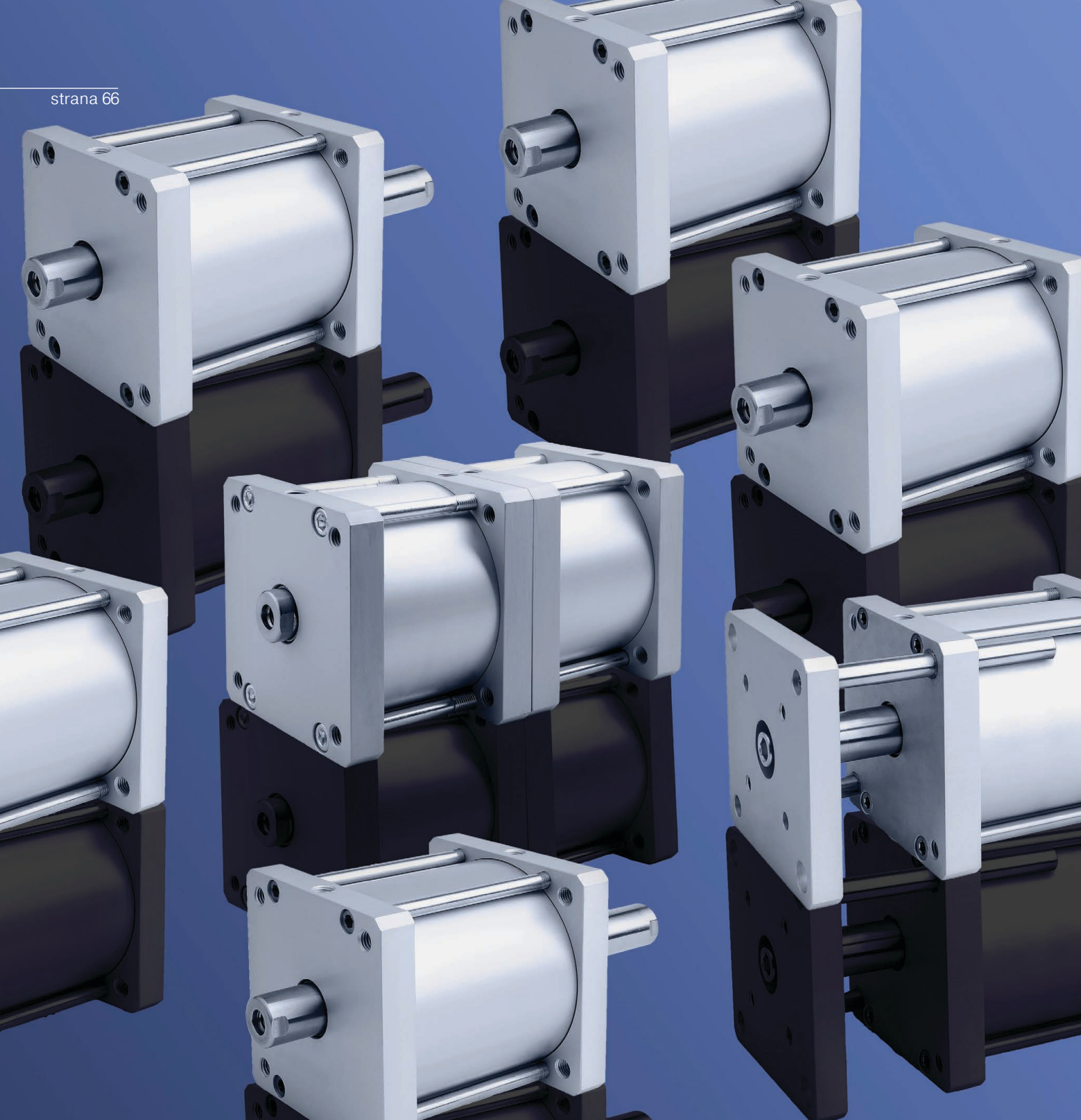

Svorníkové kompaktné valce

Všeobecný opis	
Priemer piestu	Ø125 - Ø160 - Ø200 - Ø250 mm
Štandardný zdvih	10 - 25 - 50 - 75 - 100 - 125 - 160 - 200 - 250 - 300 mm
	Jednočinný
	Dvojčinný
Pracovné médium	stlačený vzduch
Pracovný tlak	Jednočinný: 2 ... 10 bar Dvojčinný: 1 ... 10 bar
Teplota okolia	-20°C ... +80°C 0°C ... +150°C v prípade FPM tesnenia
	Pri teplotách pod 0°C je potrebné používať vhodne pripravený, suchý stlačený vzduch.
Použitý materiál	
Teleso valca	eloxovaný hliník
Kryt	eloxovaný hliník
Piest	hliník
Piestnica	nehrdzavejúca oceľ AISI 303
Vodiace puzdro	oceľ + PTFE
Tesnenia	polyuretán

J	I	N	V	125	/	50
				PRIEMER		ZDVIH
				125		10
				160		25
				200		50
				250		75
						100
						125
						160
						200
						250
						300
				VERZIE		
				PRÁZDNE	Štandardné tesnenie	
				K	FPM tesnenie stierača (v prípade valcov JI, JB, JINT do Ø200 mm)	
				V	FPM tesnenie (v prípade valcov JI, JB, JINT do Ø200 mm)	
				VERZIE		
				N	Piestnica s vnútorným závitom	
				F	Piestnica s vonkajším závitom	
				NT	S vedením zaistené proti pootočeniu (v prípade valcov JI)	
				VERZIE		
				E	Jednočinný valec	
				I	Dvojčinný valec	
				B	Dvojčinný valec, priebežná piestnica	

JEN/JEF/JIN/JIF

strana 68

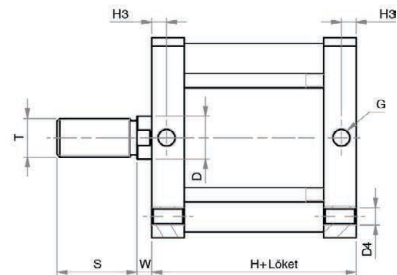
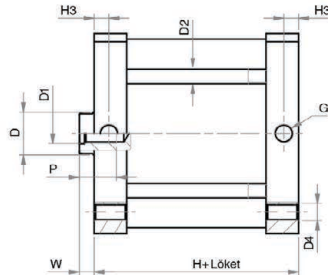
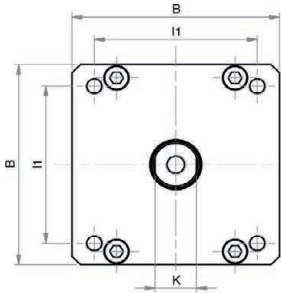
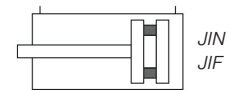
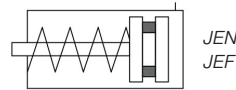
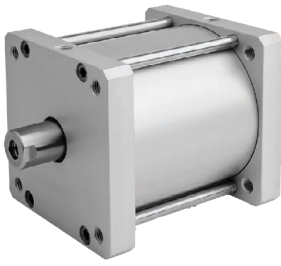

Ø [mm]	B	D	D1	D2	D4	G	H+	H+viton	H3	I1	K	P	S	T	W
Ø 125	140	30	M14	10	M12	G1/4	78	83	10	110	28	25	54	M27x2	10
Ø 160	180	40	M20	12	M16	G3/8	87	91	12	140	36	30	72	M36x2	12
Ø 200	220	40	M20	14	M16	G3/8	87	105	12	175	36	30	72	M36x2	12
Ø 250	270	40	M24	16	M20	G1/2	116	116	15	220	36	35	72	M36x2	12

JBN/JBF

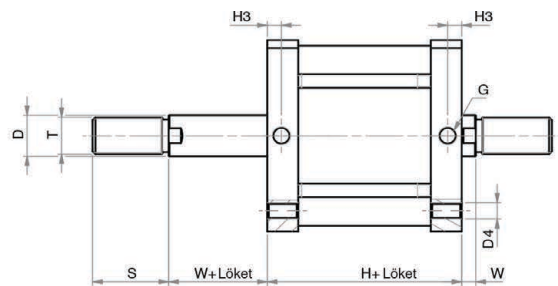
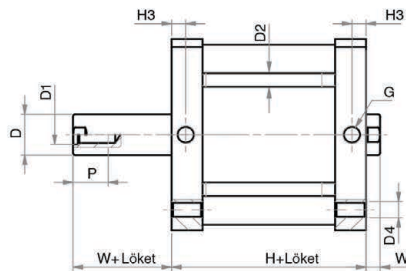
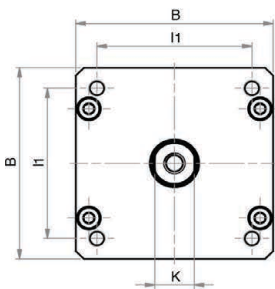
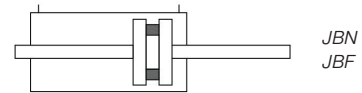
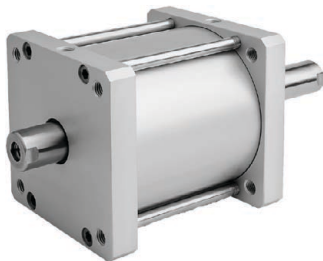

Ø [mm]	B	D	D1	D2	D4	G	H+	H+viton	H3	I1	K	P	S	T	W	W+
Ø 125	140	30	M14	10	M12	G1/4	78	83	10	110	28	25	54	M27x2	10	10
Ø 160	180	40	M20	12	M16	G3/8	87	91	12	140	36	30	72	M36x2	12	12
Ø 200	220	40	M20	14	M16	G3/8	87	105	12	175	36	30	72	M36x2	12	12
Ø 250	270	40	M24	16	M20	G1/2	116	116	15	220	36	35	72	M36x2	12	12

+ Prosíme, rátajte aj s pridaním dĺžky zdvihu!

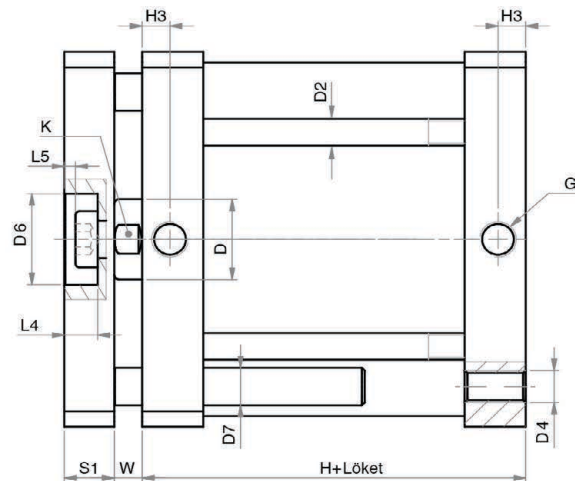
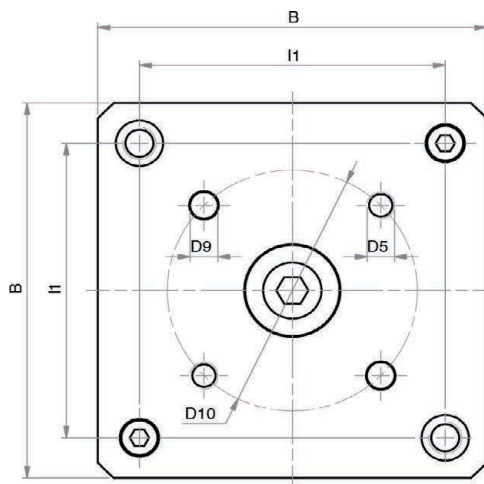
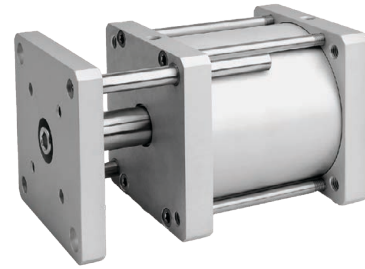
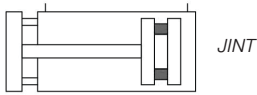

Ø [mm]	B	D	D1	D2	D4	D5	D6	D7	D9	D10
Ø 125	140	30	M14	10	M12	M10	34	14	10	90
Ø 160	180	40	M20	12	M16	M12	46	20	12	110
Ø 200	220	40	M20	14	M16	M12	46	20	12	110
Ø [mm]	G	H+	H+ viton	H3	l1	K	L4	L5	S1	W
Ø 125	G1/4	78	83	10	110	28	12	3	18	10
Ø 160	G3/8	87	91	12	140	36	16	3	23	12
Ø 200	G3/8	87	105	12	175	36	16	3	23	12

+ Prosíme, rátajte aj s pridaním dĺžky zdvihu!



Kompaktné valce s vedením

Všeobecný opis		
Priemer piestu	Ø6 - Ø8 - Ø12 - Ø16 - Ø20 - Ø25 - Ø32 - Ø40 - Ø50 - Ø63 mm A-CG04 A-CG02 A-CG01	
Štandardný zdvih	10 - 20 - 25 - 30 - 40 - 50 - 75 - 100 - 125 - 150 - 175 - 200 - 250 - 300 - 350 - 400 mm (A-CG01) 10 - 20 - 30 - 40 - 50 - 60 - 70 - 80 - 90 - 100 mm (A-CG02) 10 - 20 - 30 - 40 - 50 - 75 - 100 - 125 - 150 mm (A-CG04)	
Pracovné médium	stlačený vzduch	
Pracovný tlak	1,5 ... 7 bar (A-CG04) 0,5 ... 7 bar (A-CG02) 1 ... 10 bar (A-CG01, CC_)	
Teplota okolia	-5°C ... +60°C (S klzným ložiskom) -20°C ... +80°C (S guľôčkovým ložiskom)	
Rýchlosť	50 mm/s ... 500 mm/s	
Variácie	A-CG01, A-CG02, A-CG04 (S klzným ložiskom) CCIG6, CCBG6, CCLG6, CCVG (S guľôčkovým ložiskom)	
Použitý materiál	A_	C_
Teleso valca	hliník	hliník
Platňa	uhlíková oceľ	poniklovaná oceľ
Piestnica	Ø12 - Ø20 nehrdzavejúca oceľ Ø25 - Ø63 uhlíková oceľ	chrómovaná oceľ
Tesnenia	NBR	NBR, polyuretán

A-CG01

strana 72

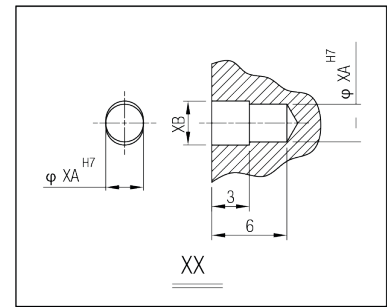
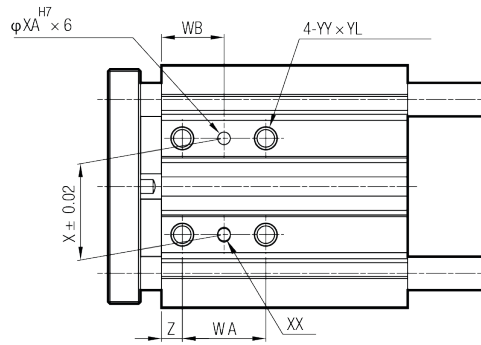
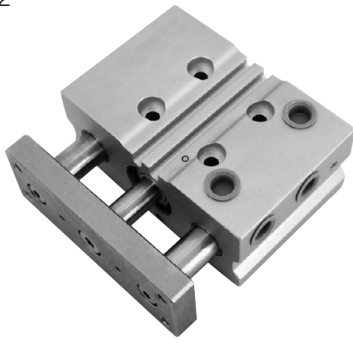

Ø12 - Ø32

Zadná strana

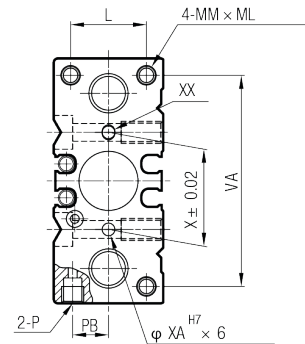
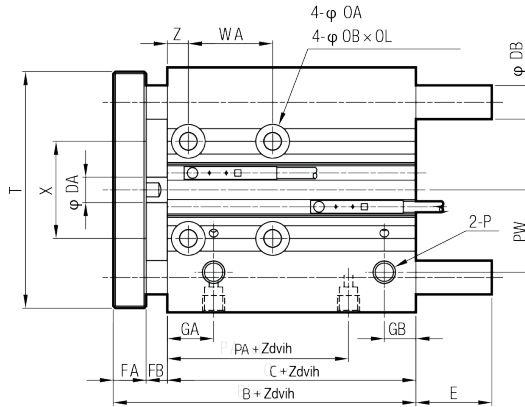
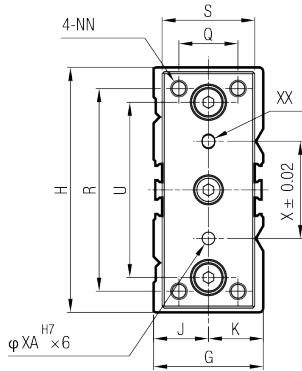

Ø	B	C	DA	DB	FA	FB	G	GA	GB	H	J	K	L	MM	ML	NN	OA	OB	OL	P	PA
Ø12	42	29	6	8	8	5	26	11	15*	58	13	13	18	M4x0,7	10	M4x0,7	4,3	8	4,5	M5x0,8	14
Ø16	46	33	8	10	8	5	30	11	18**	64	15	15	22	M5x0,8	12	M5x0,8	4,3	8	4,5	M5x0,8	15
Ø20	53	37	10	12	10	6	36	10,5	9	85	19	19	24	M5x0,8	13	M5x0,8	5,2	9,5	5,5	G1/8	12,5
Ø25	53,5	37,5	12	16	10	6	42	11,5	9	96	21	21	30	M6x1,0	15	M6x1,0	5,2	9,5	5,5	G1/8	12,5
Ø32	59,5	37,5	16	20	12	10	51	12,5	9	116	25	25	34	M8x1,25	20	M8x1,25	6,6	11,0	7,5	G1/8	7

Ø	PB	PW	Q	R	S	T	U	VA	X	XA	XB	YY	YL	Z
Ø12	8,5	18	14	48	22	56	41,5	50	23	3	3,5	M5x0,8	10	5
Ø16	10	19	16	54	25	62	46	56	24	3	3,5	M5x0,8	10	5
Ø20	11,5	25	18	70	30	81	55	72	28	3	3,5	M6x1,0	12	17
Ø25	13,5	29	26	78	38	91	65	82	34	4	4,5	M6x1,0	12	17
Ø32	16	34	30	96	44	110	80	98	42	4	4,5	M8x1,25	16	21

Ø [mm]	E		
	10-50 mm	51-100 mm	100+ mm
Ø12	-	18,5	43
Ø16	-	18,5	49
Ø20	-	31,5	69
Ø25	-	31,5	68,5
Ø32	37,5	52,5	80,5

Ø [mm]	WA					WB				
	~39 mm	40-100 mm	125-200 mm	201-300 mm	301~ mm	20-39 mm	40-100 mm	125-200 mm	201-300 mm	301~ mm
Ø12	20	40	110	200	-	15	25	60	105	-
Ø16	24	44	110	200	-	17	27	60	105	-
Ø20	24	44	120	200	300	29	39	77	117	167
Ø25	24	44	120	200	300	29	39	77	117	167
Ø32	24	48	124	200	300	33	45	83	121	171

* V prípade 19 mm zdvihu, alebo kratšieho. GB = 7,5 mm

** V prípade 19 mm zdvihu, alebo kratšieho. GB = 9 mm

Ø40 - Ø63

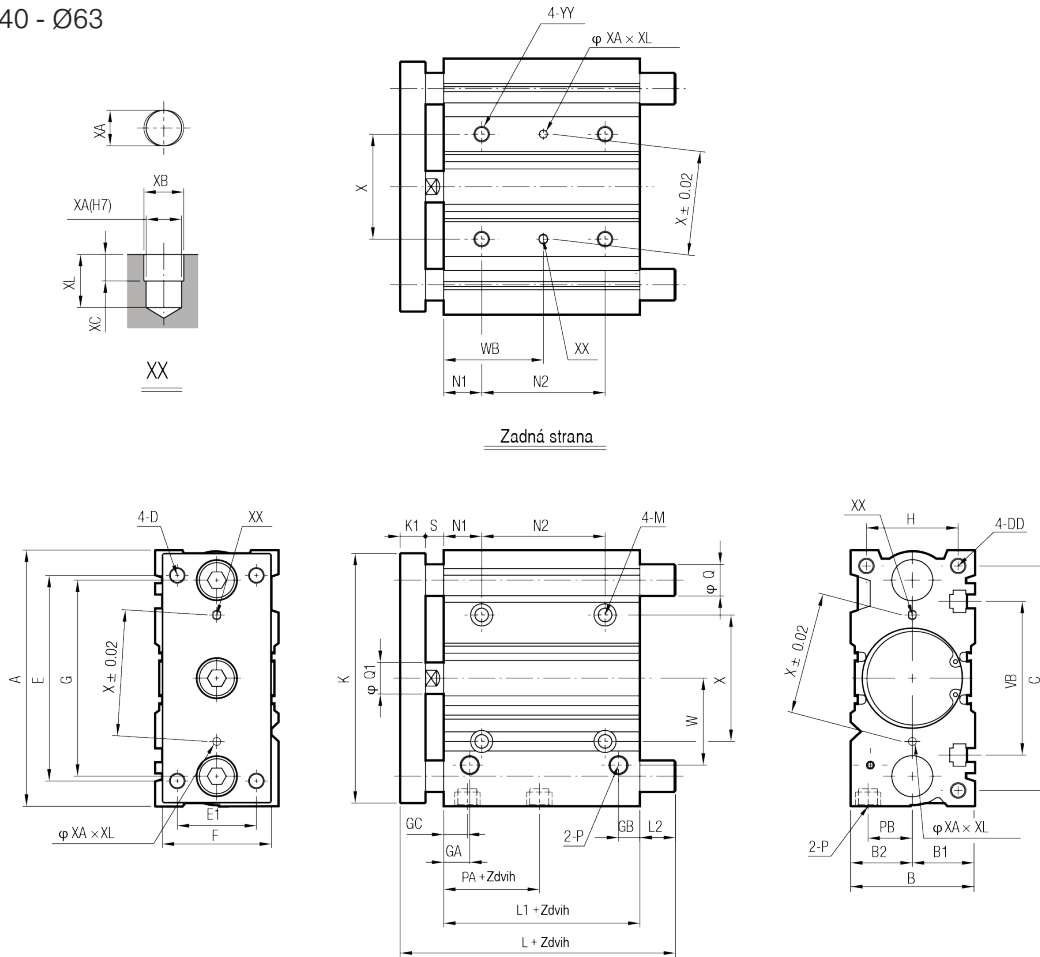

Zadná strana

Ø [mm]	A	B	B1	B2	C	D	DD	E	E1	F	G	GA	GB	GC	H	K	K1	L1
Ø40	120	54	27	27	106	M8x1,25	M8x1,25x20	104	30	44	86	14,0	10,0	14,0	40	118	12	44
Ø50	148	64	32	32	130	M10x1,5	M10x1,5x22	130	40	60	110	14,0	11,0	12,0	46	146	16	44
Ø63	162	78	39	39	142	M10x1,5	M10x1,5x22	130	50	70	124	16,5	13,5	16,5	58	158	16	49

Ø [mm]	M	N1	P	PA	PB	Q1	S	VB	W	X	XA	XB	XC	XL	YY
Ø40	Ø6,6-Ø11x7,5	22	G1/8	13	18,0	16	10	72	38	50	4	4,5	3	6,0	M8x1,25x16
Ø50	Ø8,6-Ø14,9	24	G1/4	9	21,5	20	12	92	47	66	5	6,0	4	8,0	M10x1,5x20
Ø63	Ø8,6-Ø14,9	24	G1/4	14	28,0	20	12	110	55	80	5	6,0	4	8,0	M10x1,5x20

Ø [mm]	N2			WB			L		L2		Q
	25 mm	50-100 mm	100~ mm	25 mm	50-100 mm	100~ mm	25 - 50 mm	50~ mm	25 - 50 mm	50~ mm	
Ø40	24	48	124	34	46	84	97,0	102	31,0	36	Ø20
Ø50	24	48	124	36	48	86	106,5	118	34,5	46	Ø25
Ø63	28	52	128	38	50	88	106,5	118	39,5	41	Ø25

A-CG02

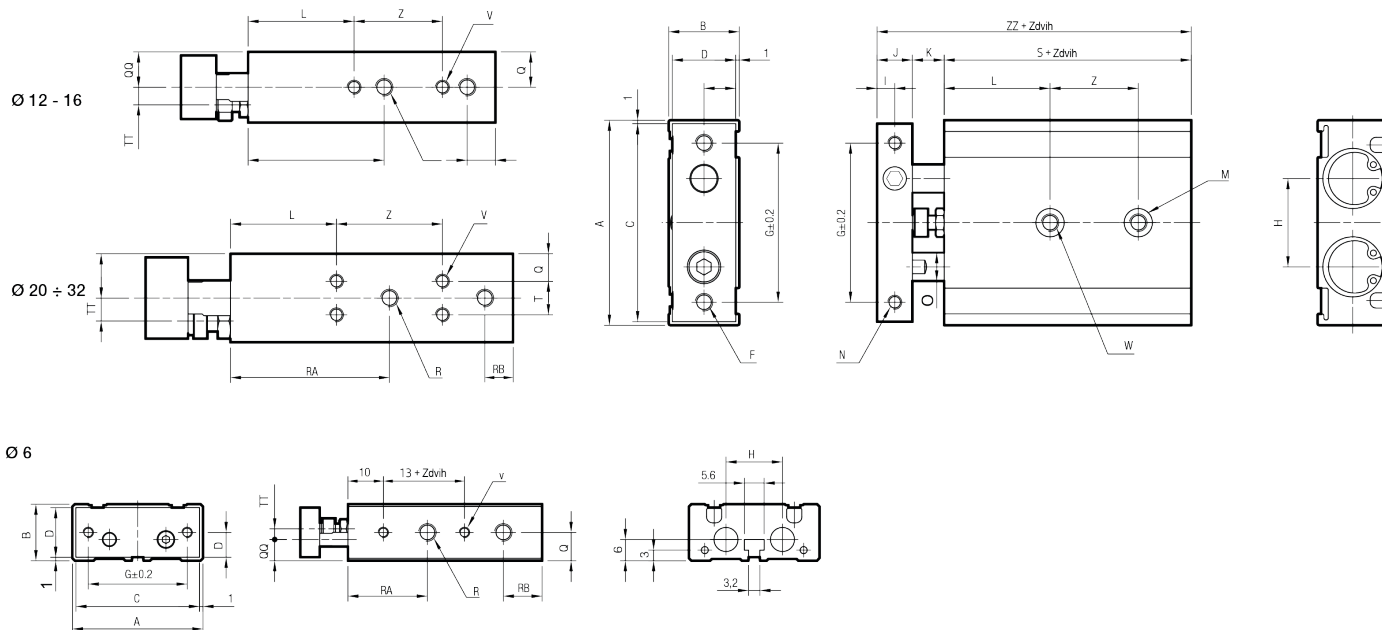
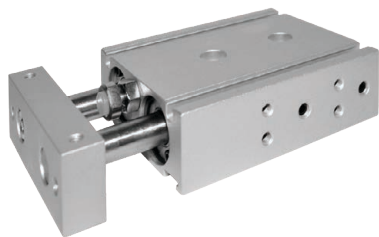

Ø [mm]	A	B	C	D	E	F	G	H	I	J	K	L	M	N	O
Ø6	37	16	35	14	7	2-M3x0,5	28	16	2,75	5,5	8	13	2-Ø6,5x3,3*	2-M3x0,5	4
Ø12	46	18	44	16	8	2-M4x0,7	35	19	4,00	8,0	9	20	4-Ø6,5x3,3	4-M3x0,5x5	6
Ø16	58	20	56	18	9	2-M5x0,8	45	25	5,00	10,0	9	30	4-Ø8x4,4	4-M4x0,7x6	8
Ø20	64	25	62	23	11,5	2-M5x0,8	50	28	6,00	12,0	12	30	4-Ø9,5x5,3	4-M4x0,7x6	10
Ø25	80	30	78	28	14	2-M6x1,0	60	35	6,00	12,0	12	30	4-Ø11x6,3	4-M4x0,8x8	12
Ø32	98	38	96	36	18	2-M6x1,0	75	44	8,00	16,0	14	30	4-Ø11x6,3	4-M4x0,8x8	16

Ø [mm]	Q	QQ	R	RA	RB	S	T	TT	V	W
Ø6	8,00	6,0	4-M5x0,8	22,5	11	45	-	3	4-M3x0,5x4,5	2-Ø3,4
Ø12	9,00	10,0	4-M5x0,8	30,0	8	55	-	3,5	4-M3x0,5x4,5	2-M4x0,7
Ø16	10,00	10,0	4-M5x0,8	38,5	8	60	-	5	4-M4x0,7x5	2-M5x0,8
Ø20	7,75	12,5	4-M5x0,8	45,0	8	70	9,5	6,5	8-M4x0,7x5,5	2-M6x1,0
Ø25	8,50	15,0	4-G1/8	46,0	9	72	13,0	9	8-M5x0,8x7,5	2-M8x1,25
Ø32	9,00	19,0	4-G1/8	56,0	10	82	20,0	11,5	8-M5x0,8x7,5	2-M8x1,25

Z (zdvih)						
Ø [mm]	10 ~ 25	30 ~ 50	60 ~ 75	80	90~100	ZZ
Ø6	10+1/2 zdvih**					58,8
Ø12	30	40	50	-	-	72
Ø16	25	35	45	45	55	79
Ø20	30	40	60	60	60	94
Ø25	30	40	60	60	60	96
Ø32	40	50	70	70	70	112

*Ø6 - iba na jednej strane

**Ø6 - v prípade zdvihov 10-20-30 mm

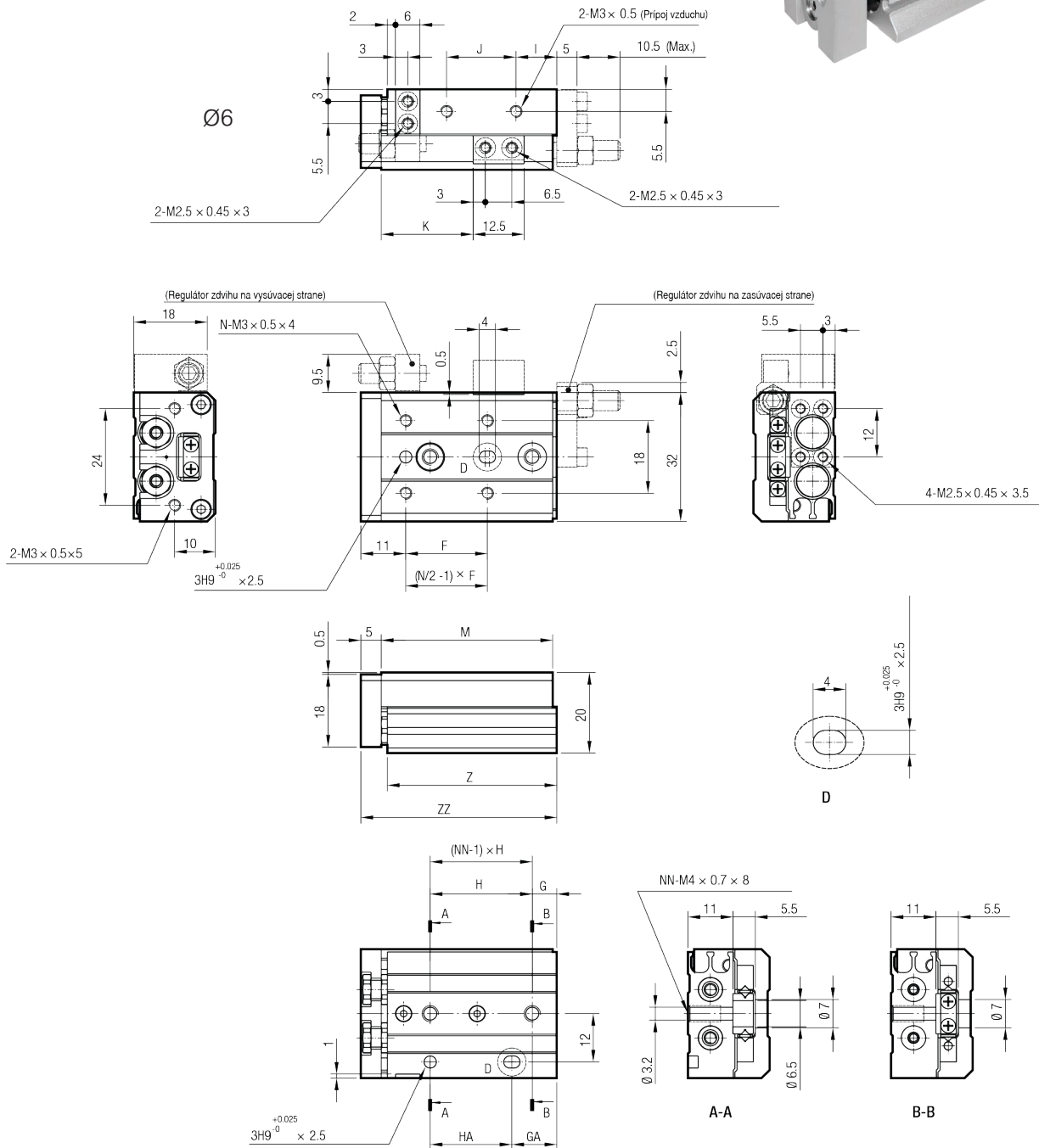
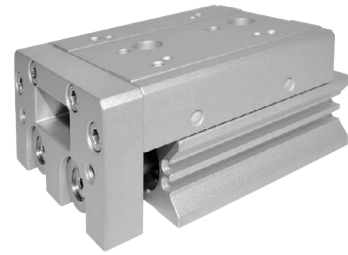

Zdvih [mm]	F	G	GA	H	HA	I	J	K	M	N	NN	Z	ZZ
10	20	6	11	25	20	10	17	22,5	42	4	2	41,5	48
20	30	6	21	35	20	10	27	32,5	52	4	2	51,5	58
30	20	11	31	20	20	7	40	42,5	62	6	3	61,5	68
40	28	13	43	30	30	19	50	52,5	84	6	3	83,5	90
50	38	17	41	24	48	25	60	62,5	100	6	4	99,5	106

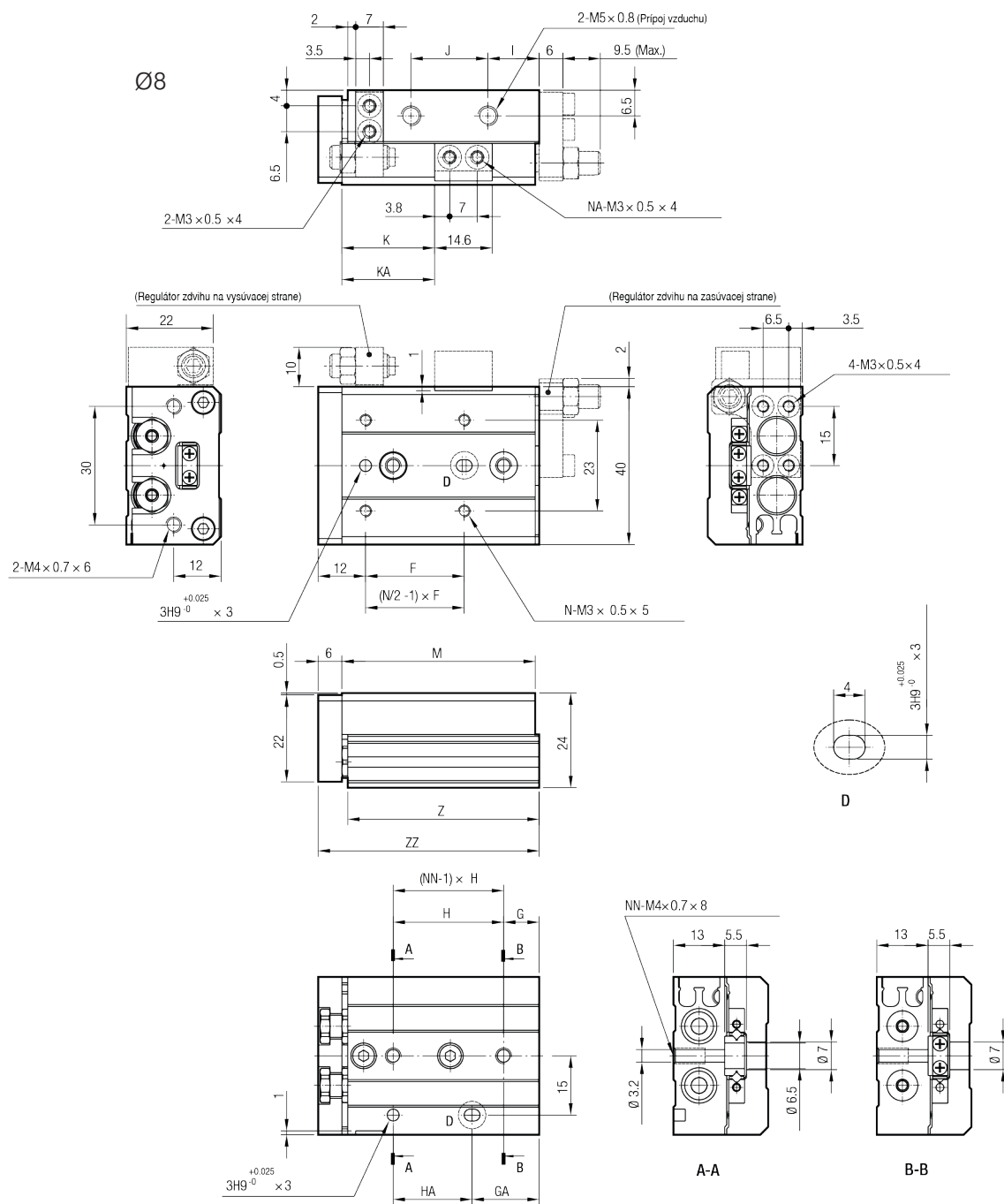

Zdvih [mm]	F	G	GA	H	HA	I	J	K	KA	M	N	NA	NN	Z	ZZ
10	25	9	17	28	20	13,0	19,5	23,5	-	49	4	2	2	48,5	56
20	25	12	12	30	30	8,5	29,0	33,5	-	54	4	2	2	53,5	61
30	40	13	33	20	20	9,5	39,0	43,5	-	65	4	2	3	64,5	72
40	50	15	43	28	28	10,5	56,0	53,5	-	83	4	2	3	82,5	90
50	38	20	43	23	46	24,5	60,0	63,5	82,5	101	6	4	4	100,5	108
75	50	27	83	56	56	38,5	96,0	88,5	132,5	151	6	4	5	150,5	158

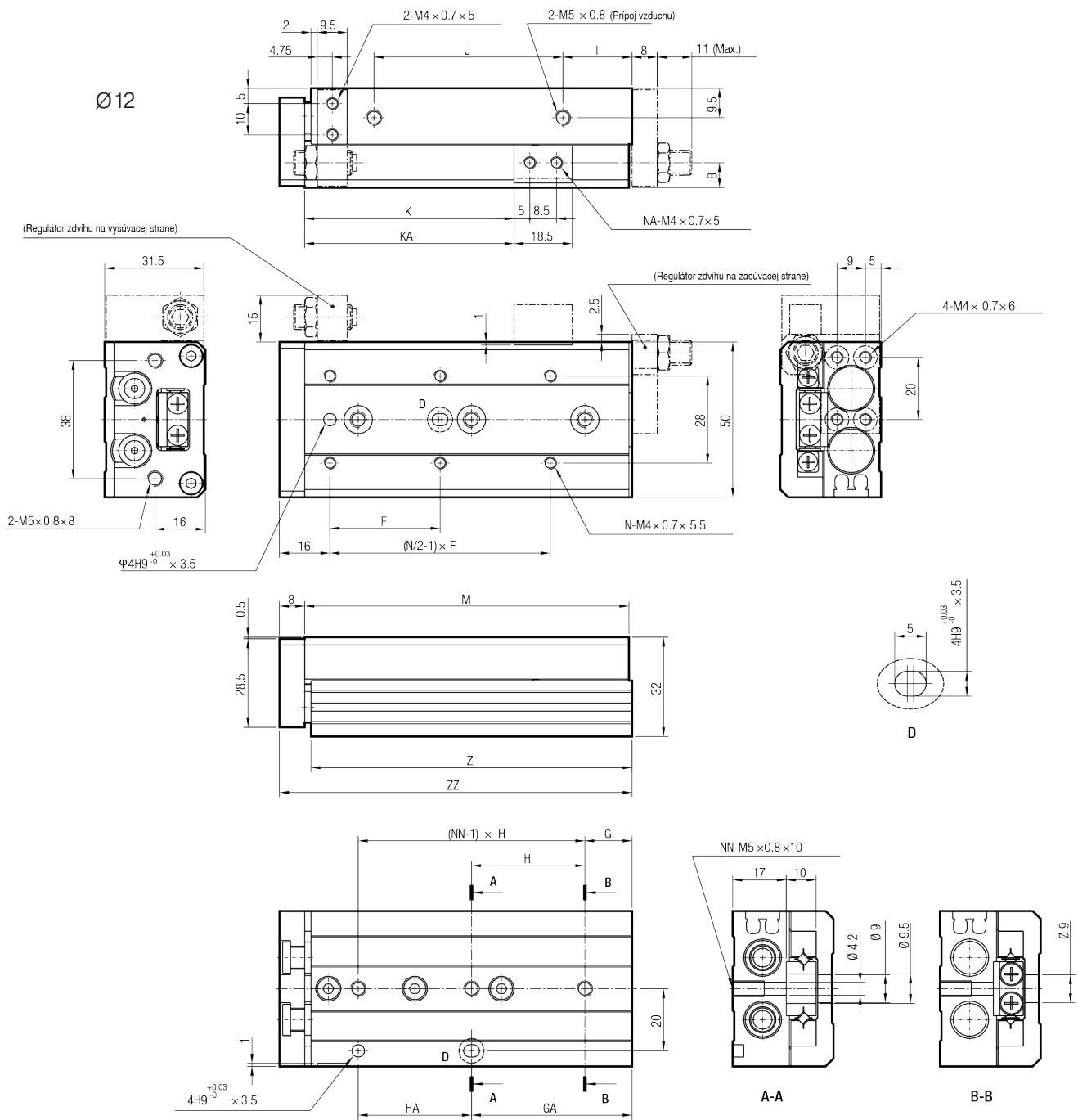

Zdvih [mm]	F	G	GA	H	HA	I	J	K	KA	M	N	NA	NN	Z	ZZ
10	35	15	15	40	40	10	40	26,5	-	71	4	2	2	70	80
20	35	15	15	40	40	10	40	36,5	-	71	4	2	2	70	80
30	35	15	15	40	40	10	40	46,5	-	71	4	2	2	70	80
40	50	17	42	25	25	10	52	56,5	-	83	4	2	3	82	92
50	35	15	51	36	36	22	60	66,5	-	103	6	2	3	102	112
75	55	25	61	36	72	43	85	91,5	125,5	149	6	4	4	148	158
100	65	35	111	38	76	52	130	116,5	116,5	203	6	4	5	202	212

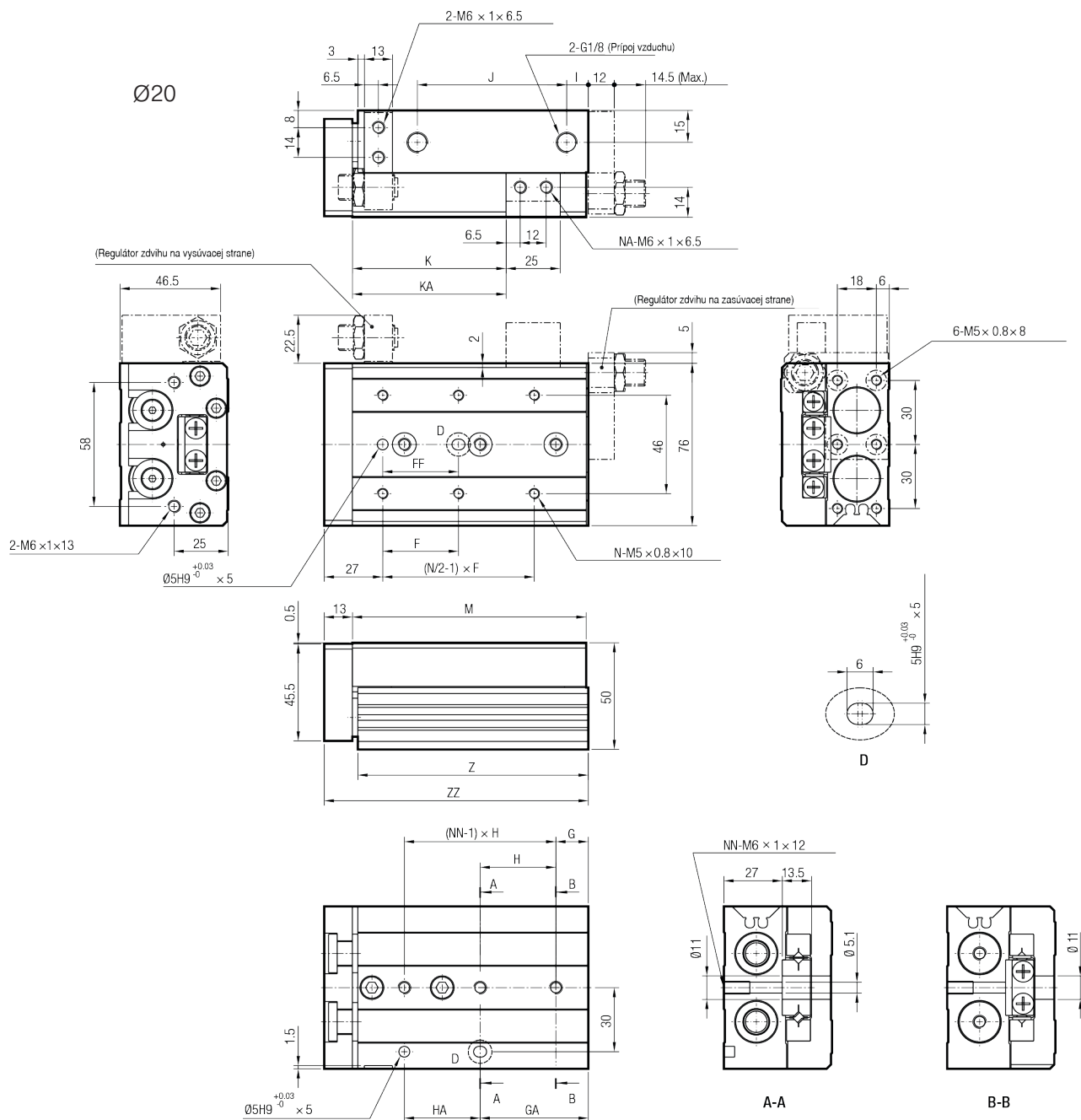

Zdvih [mm]	F	FF	G	GA	H	HA	I	J	K	KA	M	N	NA	NN	Z	ZZ
10	50	40	15	25	45	35	10	44	31	-	83	4	2	2	81,5	97
20	50	40	15	25	45	35	10	44	41	-	83	4	2	2	81,5	97
30	50	40	15	25	45	35	10	44	51	-	83	4	2	2	81,5	97
40	60	50	15	35	55	35	10	54	61	-	93	4	2	2	91,5	107
50	35	35	15	50	35	35	10	69	71	-	108	6	2	3	106,5	122
75	60	60	19	54	35	70	10	108	96	-	147	6	2	4	145,5	161
100	70	70	37	107	35	70	58	113	121	169	200	6	4	5	198,5	214
125	70	70	41	155	38	76	70	155	146	223	254	8	4	6	252,5	268
150	80	80	19	195	44	88	87	190	171	275	306	8	4	7	304,5	320

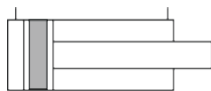

CCIG6

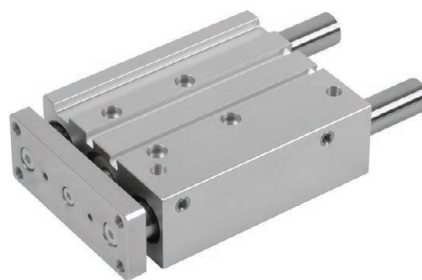

Ø12 - Ø 63 mm

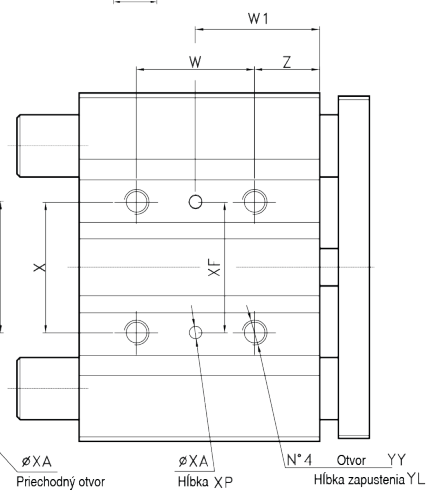
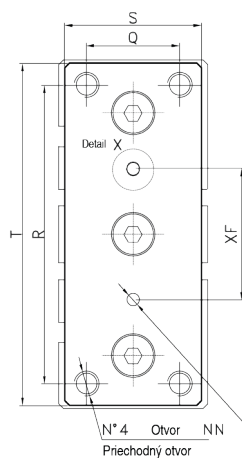
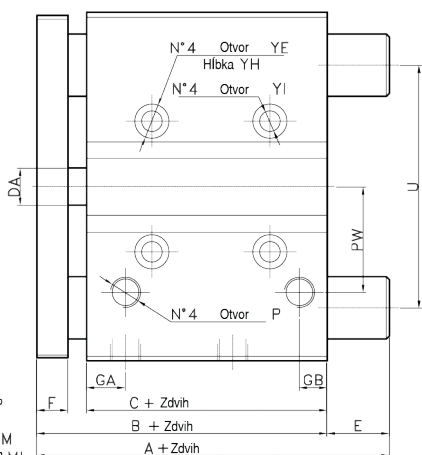
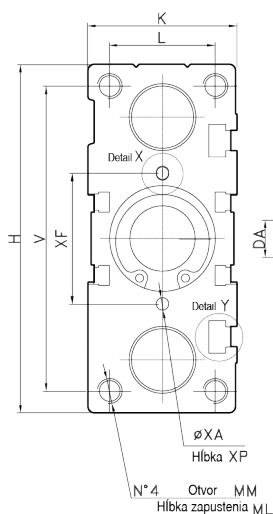
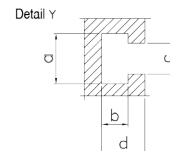
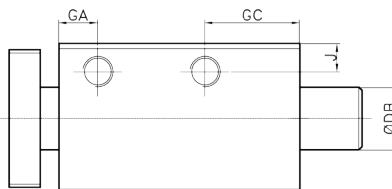
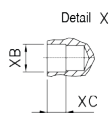

Ø [mm]	B	C	DA	F	GA	GB	GC	H	J	K	L	MM	ML	NN	P	PW	Q	R	S
Ø 12	42	29	6	7	10	7	18	58	5	26	18	M4	10	M4	M5	18	14	48	22
Ø 16	46	33	8	8	11	8	18	64	5	30	22	M5	12	M5	M5	19	16	54	25
Ø 20	53	37	10	10	10,5	8,5	24,5	83	6,5	36	24	M5	13	M5	G1/8	25	18	70	30
Ø 25	53,3	37,5	10	10	11,5	9	25	93	7,5	42	30	M6	15	M6	G1/8	28,5	26	78	38
Ø 32	59,5	37,5	12	12	12,5	9	30,5	112	9	48	34	M8	20	M8	G1/8	34	30	96	44
Ø 40	66	44	12	12	14	10	31	120	9	54	40	M8	20	M8	G1/8	38	30	104	44
Ø 50	72	44	16	16	14	11	35	148	9,5	64	46	M10	22	M10	G1/4	47	40	130	60
Ø 63	77	49	16	16	16,5	13,5	35	162	11	78	58	M10	22	M10	G1/4	55	50	130	70
Ø [mm]	T	U	V	X	YY	YL	YE	YH	YI	Z	XF	XA	XP	XB	XC	a	b	c	d
Ø 12	56	41	50	23	M4	10	8	4,5	4,3	5	23	3	6	3,5	3	7,4	3,7	4,4	6,2
Ø 16	62	46	56	24	M5	10	8	4,5	4,3	5	24	3	6	3,5	3	7,4	3,7	4,4	6,2
Ø 20	81	54	72	28	M6	12	9,5	5,5	5,6	17	28	3	6	3,5	3	8,4	4,5	5,5	7,3
Ø 25	91	64	82	34	M6	12	9,5	5,5	5,6	17	34	4	6	4,5	3	8,4	4,5	5,5	7,5
Ø 32	110	78	98	42	M8	16	11	7,5	6,6	21	42	4	6	4,5	3	10,5	5,5	6,5	9,0
Ø 40	118	86	106	50	M8	16	11	7,5	6,6	22	50	4	6	4,5	3	10,5	5,5	6,5	9,0
Ø 50	146	110	130	66	M10	20	14	9	8,6	24	66	5	8	6,0	4	13,5	7,5	8,5	12,0
Ø 63	158	124	142	80	M10	20	14	9	8,6	24	80	5	8	6,0	4	17,8	10	11,0	16,5

(S klzným ložiskom)

Ø [mm]	A (zdvih)		E (zdvih)		DB
Ø12	42 (10 - 50)	60,5 (75-100)	0 (10-50)	18,5 (75-100)	8
Ø16	46 (10-50)	64,5 (75-100)	0 (10-50)	18,5 (75-100)	10
Ø20	53 (20-50)	84,5 (75-200)	0 (20-50)	31,5 (75-200)	12
Ø25	53,5 (20-50)	85 (75-200)	0 (20-50)	31,5 (75-200)	16
Ø32	97 (25-50)	107 (75-200)	37,5 (25-50)	47,5 (75-200)	20
Ø40	97 (25-50)	107 (75-200)	31 (25-50)	41 (75-200)	20
Ø50	106,5 (25-50)	118 (75-200)	34,5 (25-50)	46 (75-200)	25
Ø63	106,5 (25-50)	118 (75-200)	29,9 (25-50)	41 (75-200)	25

(S guľôčkovým ložiskom)

Ø [mm]	A (zdvih)		E (zdvih)		DB		
Ø12	43 (10 - 30)	55 (40-100)	1 (10-30)	13 (40-100)	6		
Ø16	46 (10-30)	66 (40-100)	0 (10-30)	20 (40-100)	8		
Ø20	53 (20-30)	85,5 (40-200)	0 (20-30)	32,5 (40-200)	12		
Ø25	53,5 (20-30)	86 (40-200)	0 (20-30)	32,5 (40-200)	12		
Ø32	97 (25-50)	107 (75-200)	37,5 (25-50)	47,5 (75-200)	20		
Ø40	97 (25-50)	107 (75-200)	31 (25-50)	41 (75-200)	20		
Ø50	106,5 (25)	114 (50)	118 (75-200)	34,5 (25)	42 (50)	46 (75-200)	25
Ø63	106,5 (25)	114 (50)	118 (75-200)	29,5 (25)	37 (50)	41 (75-200)	25

Ø [mm]	W (zdvih)		W1 (zdvih)			
Ø12	20 (10 - 30)	40 (40-100)	15 (10-30)	25 (40-100)		
Ø16	24 (10-30)	44 (40-100)	17 (10-30)	27 (40-100)		
Ø20	24 (20-30)	44 (40-100)	120 (125-200)	29 (20-30)	39 (40-100)	77 (125-200)
Ø25	24 (25)	44 (40-100)	120 (125-200)	29 (20-30)	39 (40-100)	77 (125-200)

Ø [mm]	W (zdvih)		W1 (zdvih)			
Ø32	24 (25)	48 (50-100)	124 (125-200)	33 (25)	45 (50-100)	83 (125-200)
Ø40	24 (25)	48 (50-100)	124 (125-200)	34 (25)	46 (50-100)	84 (125-200)
Ø50	24 (25)	48 (50-100)	124 (125-200)	36 (25)	48 (50-100)	86 (125-200)
Ø63	28 (25-50)	52 (50-100)	128 (125-200)	38 (25)	50 (50-100)	88 (125-200)

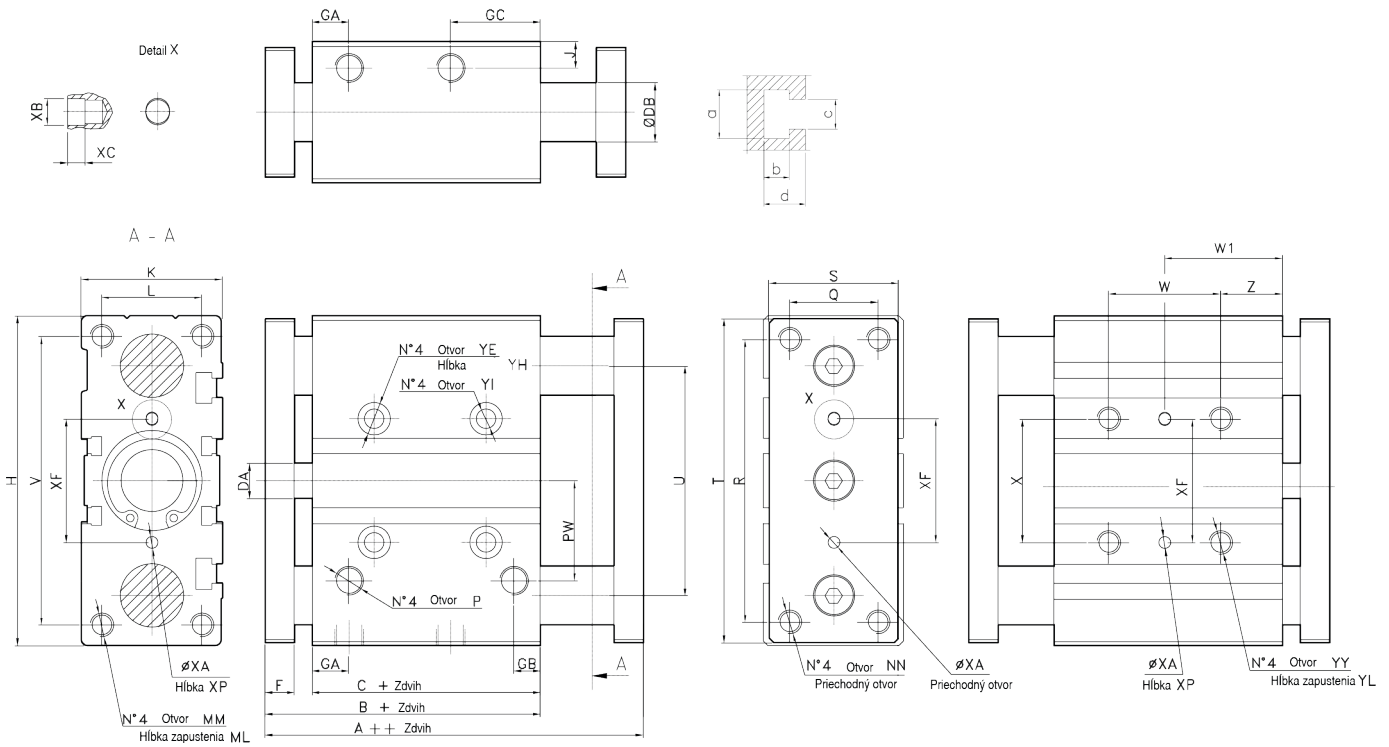
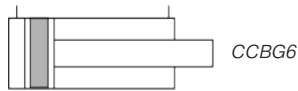

Ø	A	B	C	DA	F	GA	GB	GC	H	J	K	L	MM	ML	NN	P	PW	Q	R
Ø16	59	46	33	8	8	11	8	18	64	5	30	22	M5	12	M5	M5	19	16	54
Ø20	69	53	37	10	10	10,5	8,5	24,5	83	6,5	36	24	M5	13	M5	G1/8	25	18	70
Ø25	69,5	53,5	37,5	10	10	11,5	9	25	93	7,5	42	30	M6	15	M6	G1/8	28,5	26	78
Ø32	81,5	59,5	37,5	12	12	12,5	9	30,5	112	9	48	34	M8	20	M8	G1/8	34	30	96
Ø40	88	66	44	12	12	14	10	21	120	9	54	40	M8	20	M8	G1/8	38	30	104
Ø50	100	72	44	16	16	14	11	35	148	9,5	64	46	M10	22	M10	G1/4	47	40	130
Ø63	105	77	49	16	16	16,5	13,5	35	162	11	78	58	M10	22	M10	G1/4	55	50	130

Ø	S	T	U	V	X	XF	XA	XP	XB	XC	YY	YL	YE	YH	YI	Z	a	b	c	d
Ø16	25	62	46	56	24	24	3	6	3,5	3	M5	10	8	4,5	4,3	5	7,4	3,7	4,4	6,2
Ø20	30	81	54	72	28	28	3	6	3,5	3	M6	12	9,5	5,5	5,6	17	8,4	4,5	5,5	7,3
Ø25	38	91	64	82	34	34	4	6	4,5	3	M6	12	9,5	5,5	5,6	17	8,4	4,5	5,5	7,5
Ø32	44	110	78	98	42	42	4	6	4,5	3	M8	16	11	7,5	6,6	21	10,5	5,5	6,5	9
Ø40	44	118	86	106	50	50	4	6	4,5	3	M8	16	11	7,5	6,6	22	10,5	5,5	6,5	9
Ø50	60	146	110	130	66	66	5	8	6	4	M10	20	14	9	8,6	22	13,5	7,5	8,5	12
Ø63	70	158	124	142	80	80	5	8	6	4	M10	20	14	9	8,6	24	17,8	10	11	16,5

(S klzným ložiskom) (S gulôčkovým ložiskom)

Ø [mm]	DB	Ø [mm]	DB
Ø16	10	Ø16	8
Ø20	12	Ø20	12
Ø25	16	Ø25	12
Ø32	20	Ø32	20
Ø40	20	Ø40	20
Ø50	25	Ø50	25
Ø63	25	Ø63	25

Ø [mm]	W (zdvih)		W1 (zdvih)			
Ø16	24 (10 - 30)	44 (40-100)	17 (10-30)	27 (40-100)		
Ø20	24 (20-30)	44 (40-100)	29 (20-30)	39 (40-100)	77 (125-200)	
Ø25	24 (20-30)	44 (40-100)	120 (125-200)	29 (20-30)	39 (40-100)	77 (125-200)
Ø32	24 (25)	48 (40-100)	120 (125-200)	33 (25)	45 (50-100)	83 (125-200)
Ø40	24 (25)	48 (50-100)	124 (125-200)	34 (25)	46 (50-100)	84 (125-200)
Ø50	24 (25)	48 (50-100)	124 (125-200)	36 (25)	48 (50-100)	86 (125-200)
Ø60	28 (25)	52 (50-100)	128 (125-200)	38 (25)	50 (50-100)	88 (125-200)



Normalizované valce | ISO 15552

Normalizované valce | ISO 15552

strana 86

Všeobecný opis

Priemer piestu	Ø32 - Ø40 - Ø50 - Ø63 - Ø80 - Ø100 - Ø125 mm
Štandardný zdvih	25 - 50 - 80 - 100 - 125 - 160 - 200 - 250 - 320 - 400 - 500 - 600 - 700 - 800 - 900 - 1000 mm
Pracovné médium	stlačený vzduch
Pracovný tlak	1 ... 10 bar
Teplota okolia	-20°C ... +80°C 0°C ... +150°C v prípade FPM tesnenia
	Pri teplotách pod 0°C je potrebné používať vhodne pripravený, suchý stlačený vzduch.

Použitý materiál

Teleso valca	eloxovaný hliník
Kryt	hliníkový tlakový odliatok
Piest	hliník
Piestnica	tvrd chrómovaná oceľ
Vodiace puzdro	sinrovaný bronz
Tesnenia	polyuretán, NBR/FPM (v závislosti od typu)

H	I	F	V	32 /	80	Ex
				PRIEMER	ZDVIH	MOŽNOSTI
				32*	25 320	
				40*	40 400	
				50*	50 500	
				63*	80 600	
				80	100 700	
				100	125 800	
				125	160 900	
					200 1000	
					250	
				VERZIE		
				PRÁZDNE	Štandardné tesnenie	
				R	Piestnica z nehrdzavejúcej ocele (v prípade valcov HEF nedostupná)	
				K	FPM tesnenie stierača (v prípade valcov HEF nedostupné)	
				RK	Piestnica z nehrdzavejúcej ocele, FPM tesnenie stierača (v prípade valcov HEF nedostupná)	
				V	FPM tesnenie (v prípade valcov HEF nedostupné)	
				RV	Piestnica z nehrdzavejúcej ocele, FPM tesnenie (v prípade valcov HEF nedostupná)	
				VERZIE		
				E	Jednočinný valec (max. zdvih: 100 mm)	
				I	Dvojčinný valec	
				B	Dvojčinný valec, priebežná piestnica	

* Na požiadanie dostupné aj v prevedení s dutou tyčou na vákuum

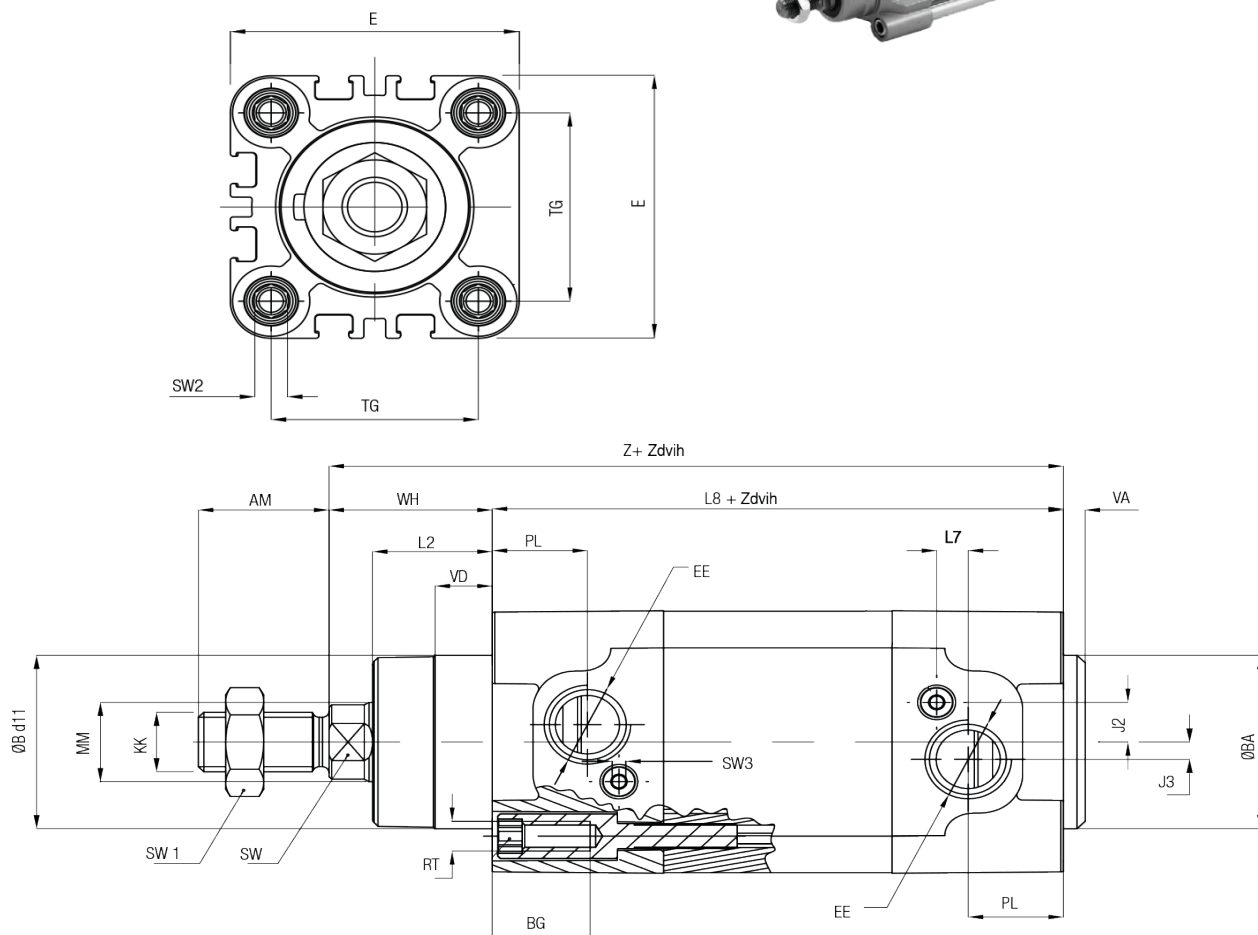
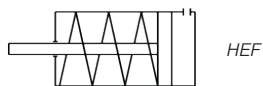

Ø [mm]	ØB d11	VD	VA	L2	WH	MM	SW	KK	AM	SW1	Z
Ø32	30	10	4	20	26	12	10	M10x1,25	22	17	145
Ø40	35	10,5	4	22	30	16	13	M12x1,25	24	19	160
Ø50	40	11,5	4	28	37	20	17	M16x1,5	32	22	168
Ø63	45	15	4	29	37	20	17	M16x1,5	32	22	183
Ø80	45	15,7	4	35	46	25	22	M20x1,5	40	30	199
Ø100	55	19,2	4	38	51,5	25	22	M20x1,5	40	30	214,5

Ø [mm]	L8	BG	RT	SW2	E	TG	EE	PL	J3	J2	L7	SW3
Ø32	119	18	M6	6	46	32,5	G1/8	18	4	6,5	2	2,5
Ø40	130	18	M6	6	54	38	G1/4	17,5	3,5	8	5,8	2,5
Ø50	131	20	M8	8	64	46,5	G1/4	20,5	7	10	2	4
Ø63	146	20	M8	8	74	56,5	G3/8	22	8	8,5	4	4
Ø80	153	19	M10	6	94	72	G3/8	22	11	8,5	4	4
Ø100	163	19	M10	6	111	89	G1/2	26	9	12,5	5	4

HIF/HIFO/HBF

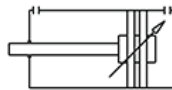
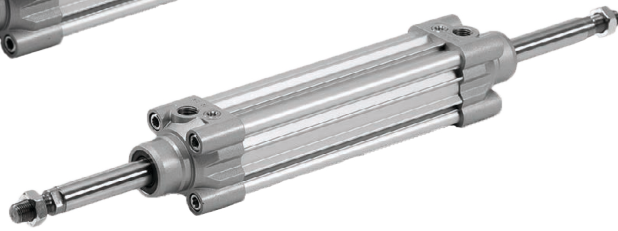

HIF

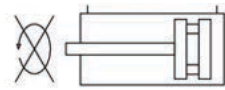

HIFO

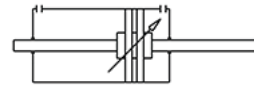

HBF

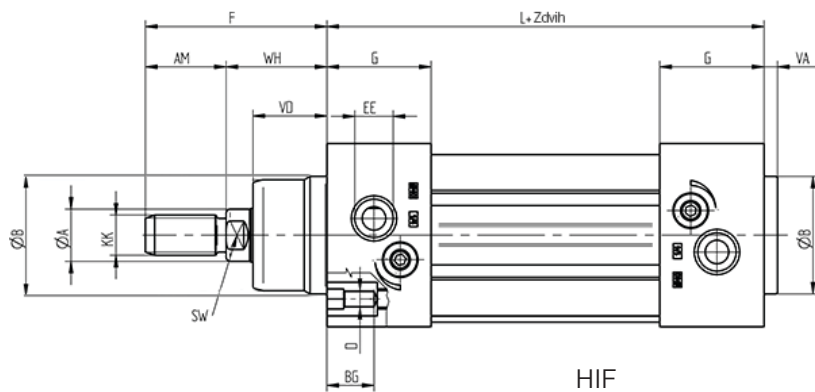

HIF

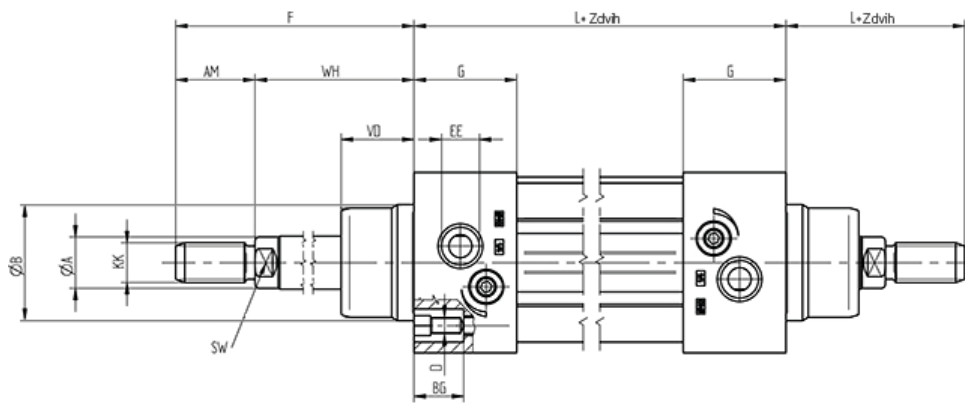
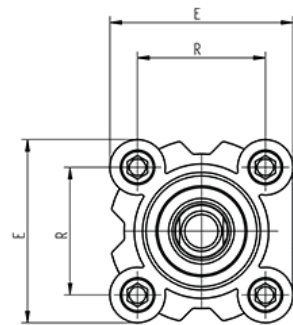

HBF

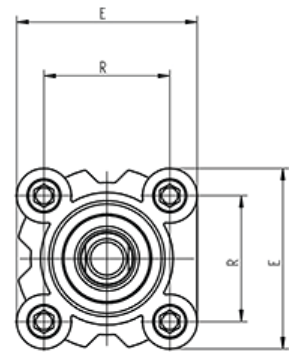

Ø [mm]	A	B	D	E	F	G	L	R	AM	BG	EE	KK	SW	VA	VD	WH
Ø32	12	30	M6	47	48	26,5	94	32,5	22	16	G1/8	M10x1,25	10	4	18	26
Ø40	16	35	M6	54,5	54	31	105	38	24	16	G1/4	M12x1,25	13	4	22	30
Ø50	20	40	M8	65	69	31	106	46,5	32	16	G1/4	M16x1,5	17	4	25,5	37
Ø63	20	45	M8	75	69	33,5	121	56,5	32	16	G3/8	M16x1,5	17	4	26	37
Ø80	25	45	M10	93	86	40	128	72	40	17	G3/8	M20x1,5	22	4	32	46
Ø100	25	55	M10	110	91	40,5	138	89	40	17	G1/2	M20x1,5	22	4	38	51
Ø125	32	60	M12	134	119	47	160	110	54	20	G1/2	M27x2	27	6	46	65

Všeobecný opis	
Priemer piestu	Ø32 - Ø40 - Ø50 - Ø63 - Ø80 - Ø100 - Ø125 mm
Štandardný zdvih	25 - 50 - 80 - 100 - 125 - 160 - 200 - 250 - 320 - 400 - 500 - 600 - 700 - 800 - 900 - 1000 mm
Pracovné médium	stlačený vzduch
Pracovný tlak	1 ... 10 bar
Teplota okolia	-20°C ... +80°C
Pri teplotách pod 0°C je potrebné používať vhodne pripravený, suchý stlačený vzduch.	

Použitý materiál	
Teleso valca	eloxovaný hliník
Kryt	hliníkový tlakový odliatok
Piest	hliník
Piestnica	tvrd chrómovaná oceľ
Vodiace puzdro	sintrovaný bronz
Tesnenia	polyuretán, NBR

T H I F				32 / 2 X			80 Ex	
VERZIE				PRIEMER	POČET VALCOV	ZDVIH	MOŽNOSTI	
T				32	2	25	Ex II 2GD c T4	
				40	3	40		
				50	4	50		
				63		80		
				80		100		
				100		125		
				125		160		
						200		
						250		
						320		
						400		
						500		
						600		
						700		
						800		
						900		
						1000		

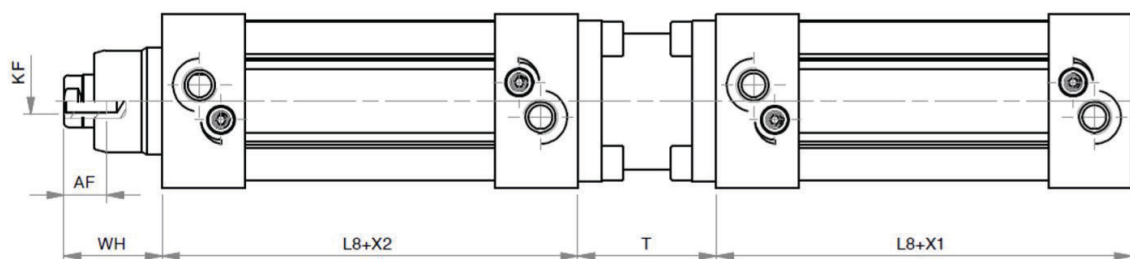
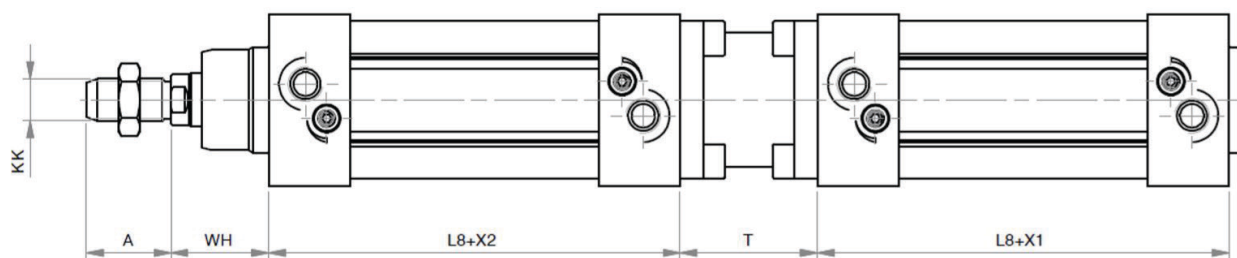
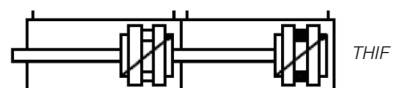
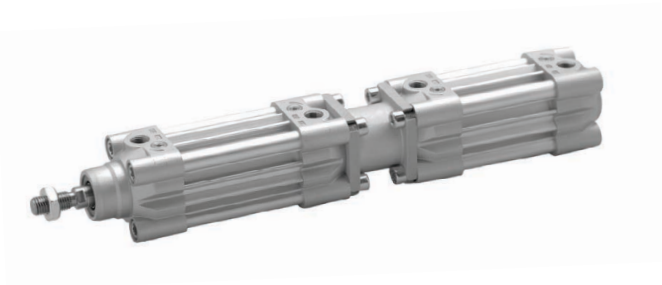

x1, x2: Zdvih

Ø [mm]	A	AF	KF	KK	L8	T	WH
Ø32	22	12	M6	M10x1,25	94	39	26
Ø40	24	12	M8	M12x1,25	105	45	30
Ø50	32	16	M8	M16x,15	106	52	37
Ø63	32	16	M10	M16x1,5	121	53	37
Ø80	40	20	M10	M20x1,5	128	65	46
Ø100	40	20	M12	M20x1,5	138	77	51
Ø125	54	32	M16	M27x2	160	93	65

Všeobecný opis	
Priemer piestu	Ø32 - Ø40 - Ø50 - Ø63 - Ø80 - Ø100 - Ø125 mm
Štandardný zdvih	25 - 50 - 80 - 100 - 125 - 160 - 200 - 250 - 320 - 400 - 500 - 600 - 700 - 800 - 900 - 1000 mm
Pracovné médium	stlačený vzduch
Pracovný tlak	1 ... 10 bar
Teplota okolia	-20°C ... +80°C 0°C ... +150°C v prípade FPM tesnenia
Pri teplotách pod 0°C je potrebné používať vhodne pripravený, suchý stlačený vzduch.	

Použitý materiál	DILA	DIL, DBL
Teleso valca	eloxovaný hliník	eloxovaný hliník
Kryt	hliníkový tlakový odliatok	hliníkový tlakový odliatok
Piest	hliník	technopolymér
Piestnica	tvrd chrómovaná oceľ	tvrd chrómovaná oceľ
Vodiace puzdro	sintrovaný bronz	sintrovaný bronz
Tesnenia	polyuretán, NBR	polyuretán, NBR

D	I	L	V	32 / 80
				PRIEMER
				32
				40
				50
				63
				80
				100
				125
				ZDVIH
				25
				40
				50
				80
				100
				125
				160
				200
				250
				320
				400
				500
				600
				700
				800
				900
				1000
VERZIE				
PRÁZDNE Štandardné tesnenie				
A Hliníkový piest				
R Piestnica z nehrdzavejúcej ocele				
V FPM tesnenie				
VERZIE				
I Dvojčinný valec				
B Dvojčinný valec, priebežná piestnica				

DIL/DILA/DBL

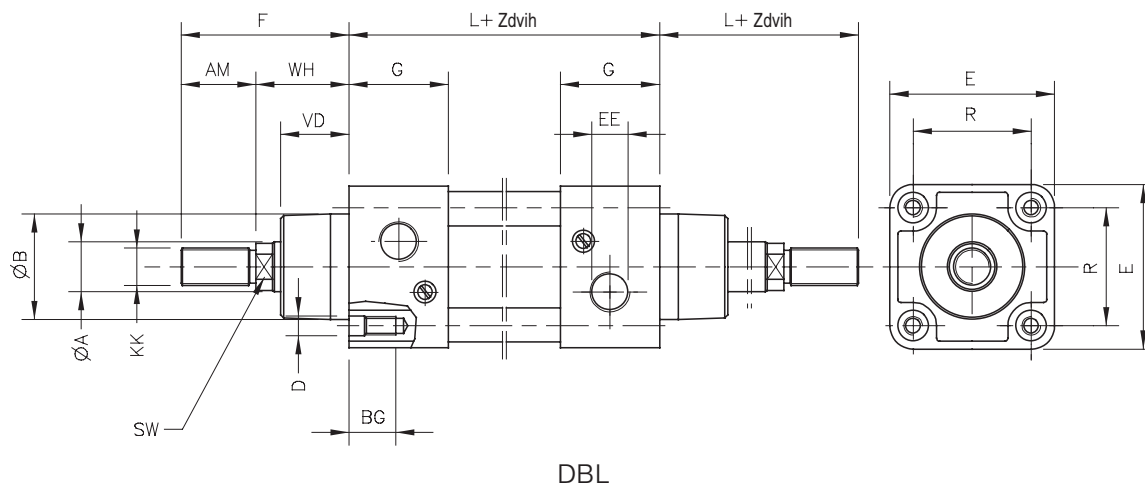
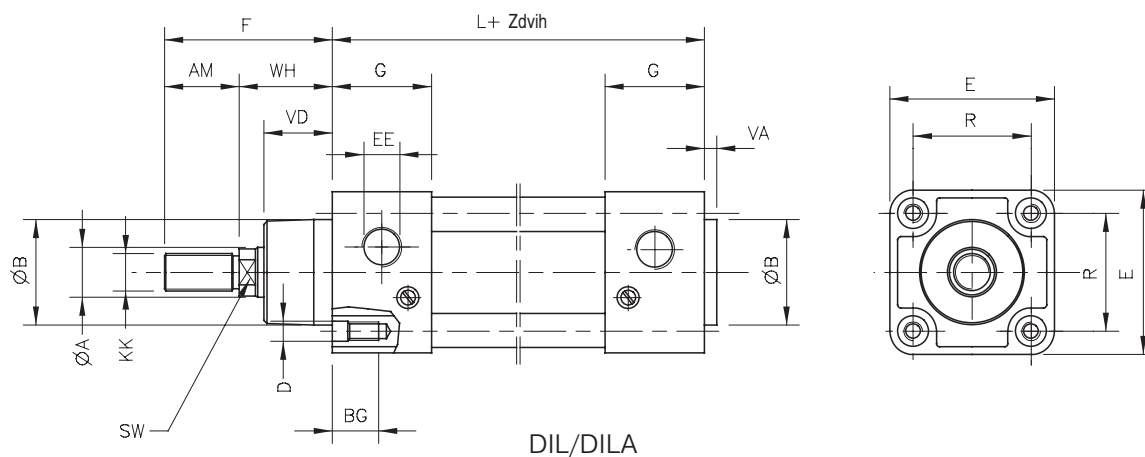
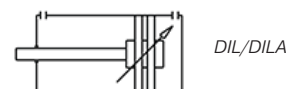
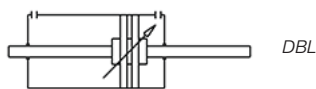

Ø [mm]	A	B	D	E	F	G	L	R	AM	BG	EE	KK	SW	VA	VD	WH
Ø32	12	30	M6	47	48	28	94	32,5	22	16	G1/8	M10x1,25	10	4	20	26
Ø40	16	35	M6	53	54	31,5	105	38	24	16	G1/4	M10x1,25	13	4	22	30
Ø50	20	40	M8	65	69	31,5	106	46,5	32	16	G1/4	M16x1,5	16	4	28	37
Ø63	20	45	M8	75	69	35	121	56,5	32	16	G3/8	M16x1,5	16	4	28	37
Ø80	25	45	M10	95	86	36	128	72	40	16	G3/8	M20x1,5	21	4	34	46
Ø100	25	55	M10	115	91	41	138	89	40	16	G1/2	M20x1,5	21	4	38	51
Ø125	32	60	M12	140	119	45	160	110	54	20	G1/2	M27x2	27	5	50	65

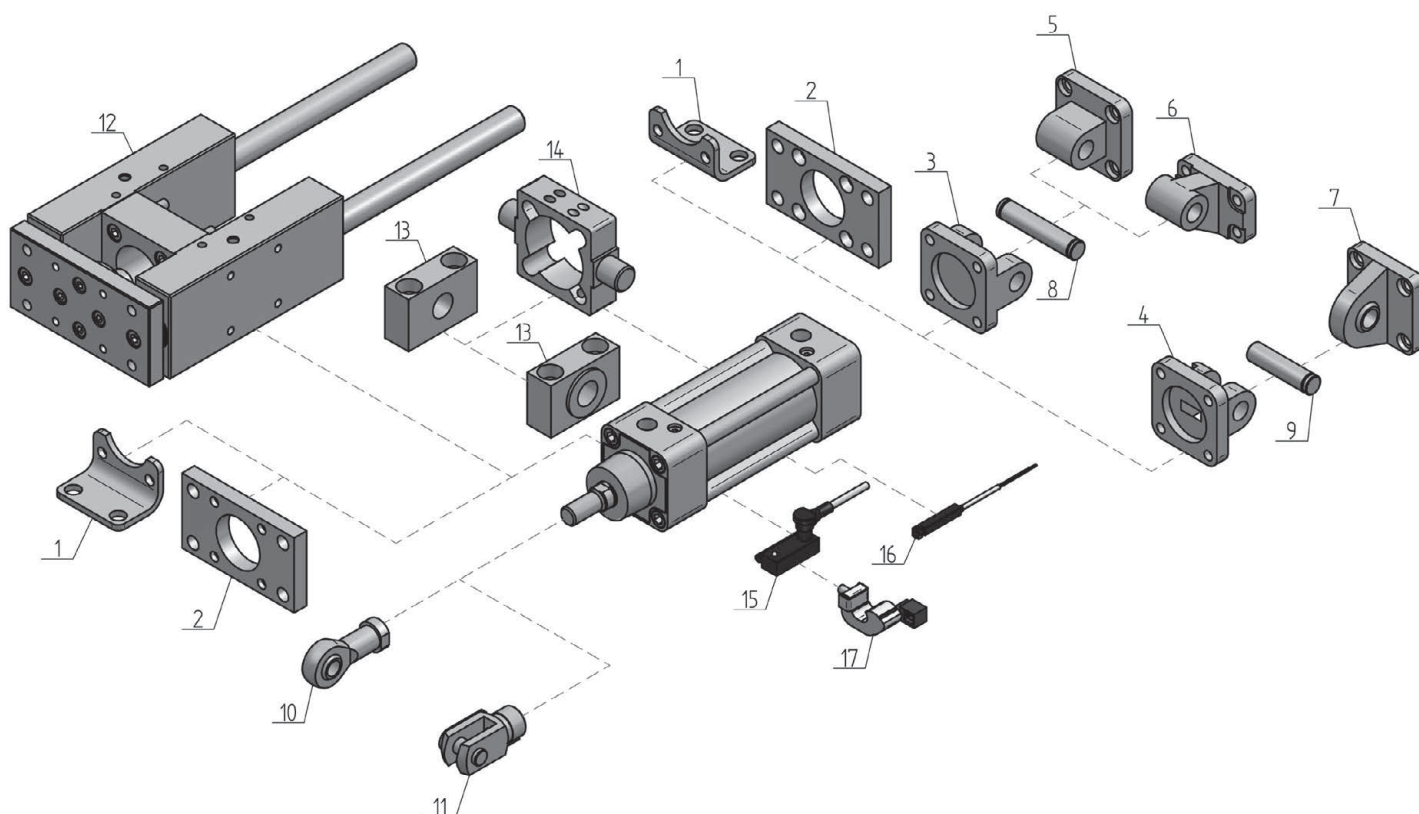

Označenie	Typ	Pomenovanie	Strana
1	DL	Pätkové upevnenie - rozmery upevnenia podľa ISO-VDMA	141
2	DF	Príruba - rozmery upevnenia podľa ISO-VDMA	140
3	DG	Vidlicová príruha - rozmery upevnenia podľa ISO-VDMA	142
4	DGS	Vidlicová príruha ku kĺbovej príruhe	142
5	DH	Príruba s okom - rozmery upevnenia podľa ISO-VDMA	143
6	DW	Príruba s okom (90°) - rozmery upevnenia podľa ISO-VDMA	145
7	DKL	Kĺbová príruha - rozmery upevnenia podľa ISO-VDMA	145
8	DC	Upínací kolík - rozmery upevnenia podľa ISO-VDMA	146
9	DCS	Upínací kolík k DGS príruhe - rozmery upevnenia podľa ISO-	146
10	UK	Kĺbová hlavica	135
11	UV	Vidlicová koncovka s upevňovacím čapom	134
12	DHS/DHSL	Lineárne H vedenie	155
12	DHG/DHGL	Lineárne H vedenie	156
13	DSL	Konzola na upevnenie	141
14	DS (Pre DIL valce)	Výkyvné upevnenie	144
14	DP (Pre HIF valce)	Výkyvné upevnenie - Pre valce s plochým profilom	144
15	SM	Snímač - REED relé / jazýčkové relé	150
16	SKR/SKH	Snímač	149
17	DXS	Upevňovacia jednotka pre SKR/SKH snímač	151

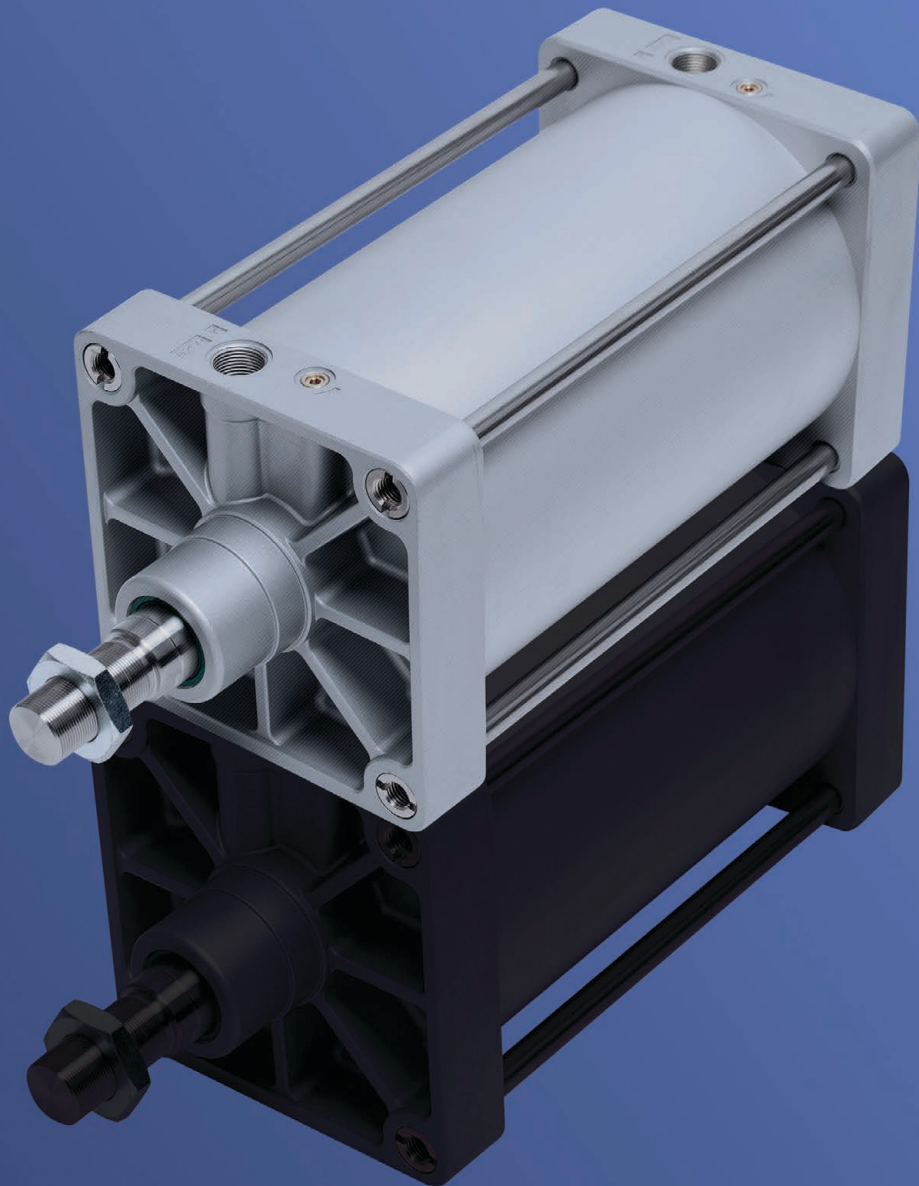

Svorníkové valce | ISO 15552

Všeobecný opis	
Priemer piestu	Ø160 - Ø200 - Ø250 - Ø320 mm
Štandardný zdvih	25 - 50 - 80 - 100 - 125 - 160 - 200 - 250 - 320 - 400 - 500 - 600 - 700 - 800 - 900 - 1000 mm
Pracovné médium	stlačený vzduch
Pracovný tlak	1 ... 10 bar
Teplota okolia	-20°C ... +80°C
Pri teplotách pod 0°C je potrebné používať vhodne pripravený, suchý stlačený vzduch.	

Použitý materiál	
Teleso valca	eloxovaný hliník
Kryt	hliníkový tlakový odliatok
Piest	hliník
Piestnica	nehrdzavejúca oceľ / tvrdo chrómovaná oceľ
Vodiace puzdro	sintrovaný bronz
Tesnenia	polyuretán, NBR

D	I	M	160	/	200
			PRIEMER	ZDVIH	
			160	25	
			200	50	
			250	80	
			320	100	
				125	
				160	
				200	
				250	
				320	
				400	
				500	
				600	
				700	
				800	
				900	
				1000	
VERZIE					
I			Dvojčinný valec		

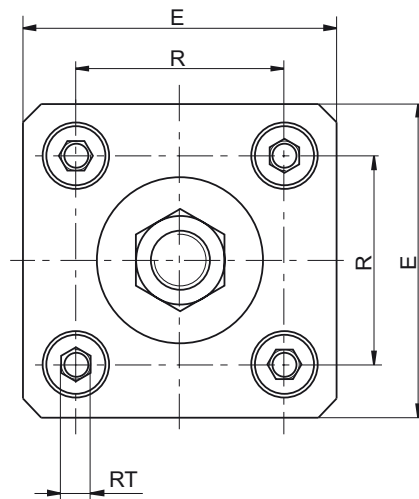
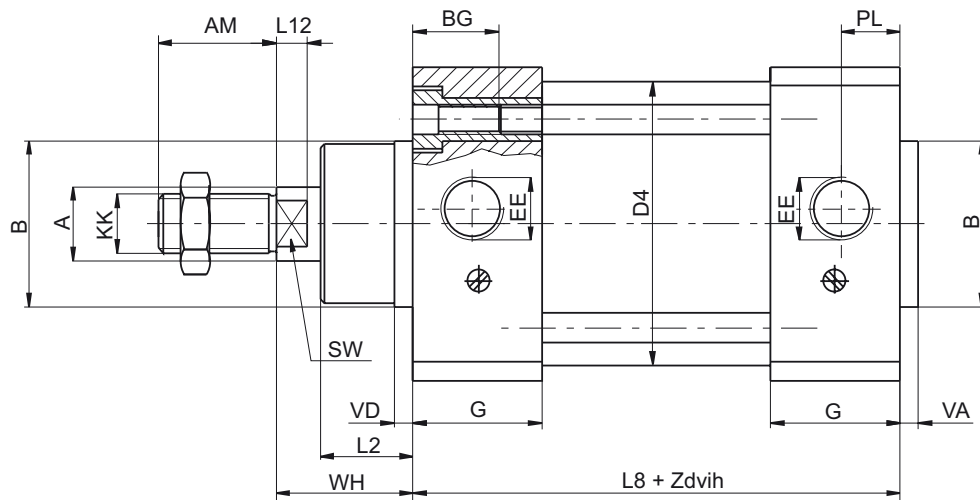
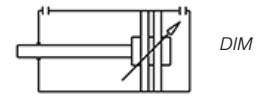

Ø [mm]	A	AM	B	BG	D4	E	EE	G	KK	L2	L8	L12	PL	R	RT	SW	VA	VD	WH
Ø160	40	72	65	24	170	182	G3/4	59	M36x2	38	180	12	27	140	M16	38	6	6	80
Ø200	40	72	75	24	210	222	G3/4	61	M36x2	55	180	12	35	175	M16	38	6	6	95
Ø250	50	84	90	25	264	274	G1	61	M42x2	65	200	20	31	220	M20	46	10	10	105
Ø320	60	96	110	28	336	352	G1	63	M42x2	75	220	20	34	270	M24	55	10	10	120

Všeobecný opis	
Priemer piestu	Ø160 - Ø200 - Ø250 - Ø320 mm
Štandardný zdvih	50 - 80 - 100 - 125 - 150 - 160 - 200 - 250 - 320 - 400 - 500 - 600 - 700 - 800 - 900 - 1000 mm
Pracovné médium	stlačený vzduch
Pracovný tlak	1 ... 10 bar
Teplota okolia	-20°C ... +80°C 0°C ... +150°C v prípade FPM tesnenia
Pri teplotách pod 0°C je potrebné používať vhodne pripravený, suchý stlačený vzduch.	

Použitý materiál	
Teleso valca	eloxovaný hliník
Kryt	hliníkový tlakový odliatok
Piest	hliník
Piestnica	nehrdzavejúca oceľ
Vodiace puzdro	sintovaný bronz
Tesnenia	polyuretán, NBR/FPM (v závislosti od typu)

U	D	M	N	V	160	/	200	Ex
					PRIEMER		ZDVIH	MOŽNOSTI
					160		50	⊕ II 2GD c T4
					200		80	
					250		100	
					300		125	
							160	
							200	
							250	
							320	
							400	
							500	
							600	
							700	
							800	
							900	
							1000	
					VERZIE			
					PRÁZDNE Štandardné tesnenie			
					R Piestnica z nehrdzavejúcej ocele			
					K FPM tesnenie stierača			
					V FPM tesnenie stierača (dostupné do Ø250 mm)			
					P Prieběžná piestnica			
					VERZIE			
					PRÁZDNE Piestnica s vonkajším závitom			
					N Piestnica s vnútorným závitom			

UDM

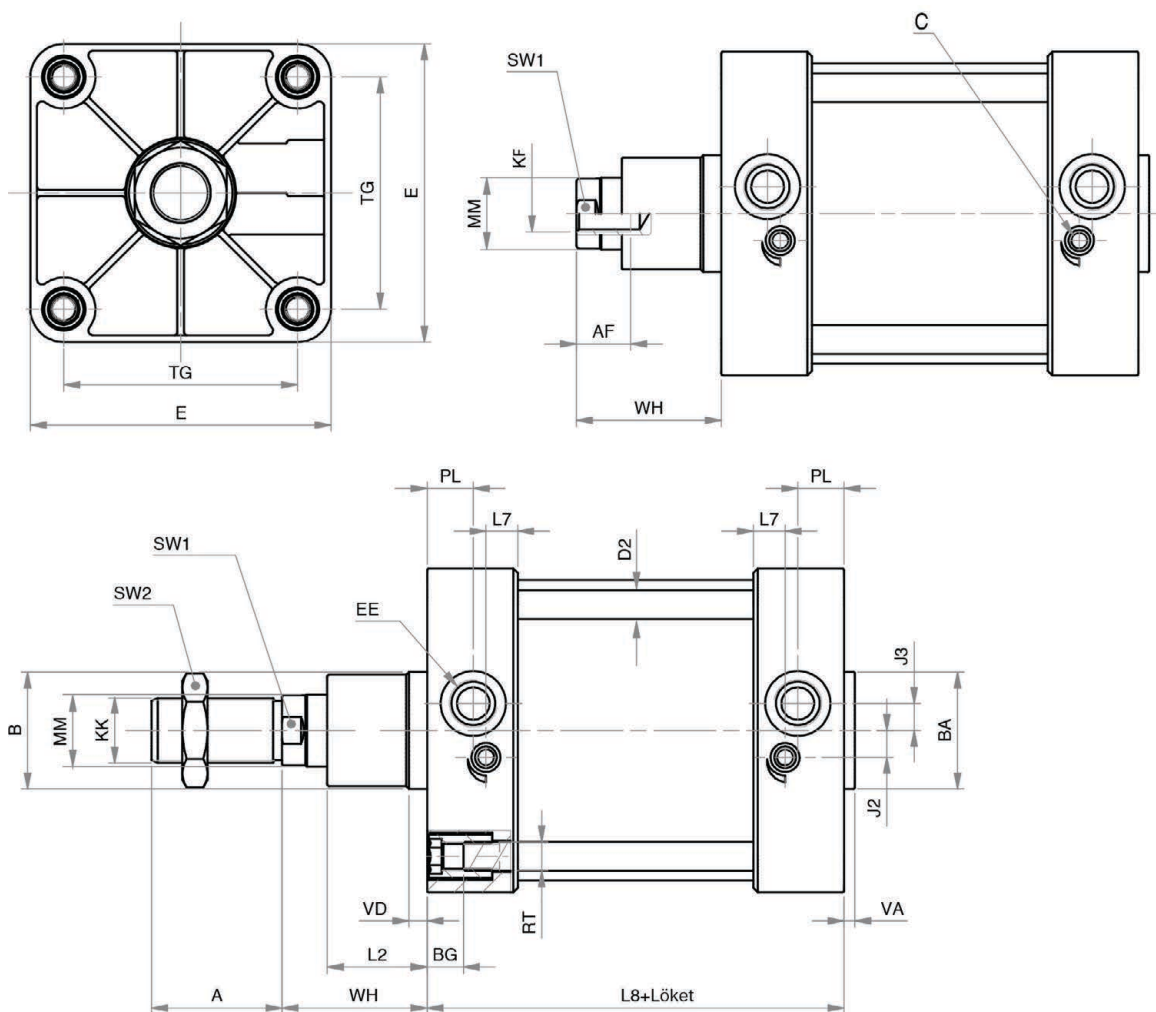
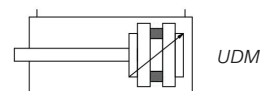
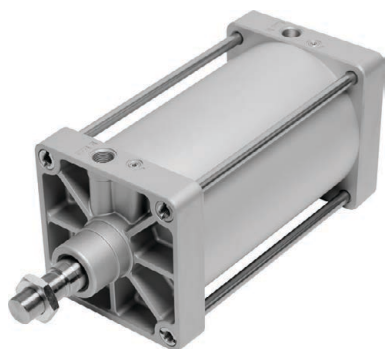

Ø [mm]	A	AF	B	BA	BG	D2	E	EE	J2	J3	KF	KK	L2	L7	L8+	MM	PL	RT	SW1	SW2	TG	VA	VD	WH
Ø160	72	30	65	65	24	16	180	G3/4	15	15	M20	M36x2	55	17,5	180	40	25,5	M16	36	55	140	6	10	80
Ø200	72	30	75	75	24	16	220	G3/4	15	15	M20	M36x2	65	16	180	40	25,5	M16	36	55	175	8	25	95
Ø250	84	40	90	90	25	20	270	G1	25	25	M24	M42x2	75	20	200	50	30	M20	46	65	220	8	25	105
Ø320	96	50	110	110	28	25	350	G1	35	35	M30	M48x2	90	20	220	63	30	M24	55	75	270	10	25	120

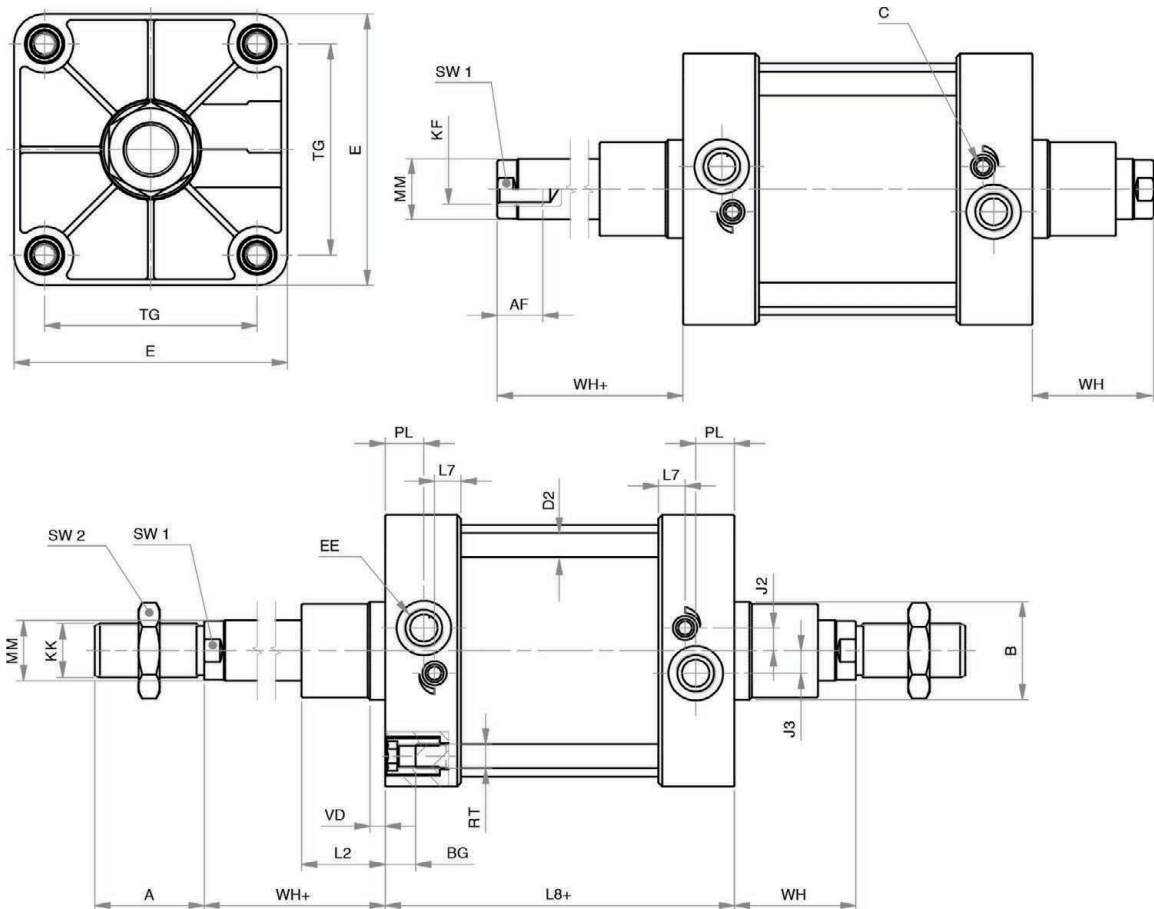
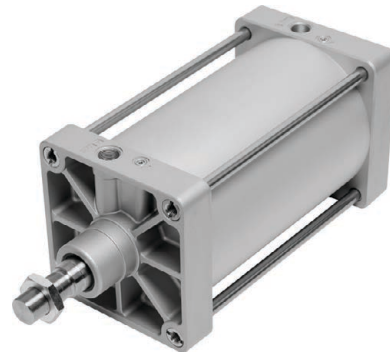
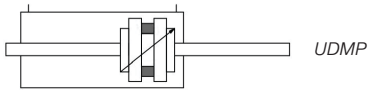

Ø [mm]	A	AF	B	BG	D2	E	EE	J2	J3	KF	KK	L2	L7	L8+	MM	PL	RT	SW1	SW2	TG	VD	WH	WH+
Ø160	72	30	65	24	16	180	G3/4	15	15	M20	M36x2	55	17,5	180	40	25,5	M16	36	55	140	10	80	80
Ø200	72	30	75	24	16	220	G3/4	15	15	M20	M36x2	65	16	180	40	25,5	M16	36	55	175	25	95	95
Ø250	84	40	90	25	20	270	G1	25	25	M24	M42x2	75	20	200	50	30	M20	46	65	220	25	105	105
Ø320	96	50	110	28	25	350	G1	35	35	M30	M48x2	90	20	220	63	30	M24	55	75	270	25	120	120

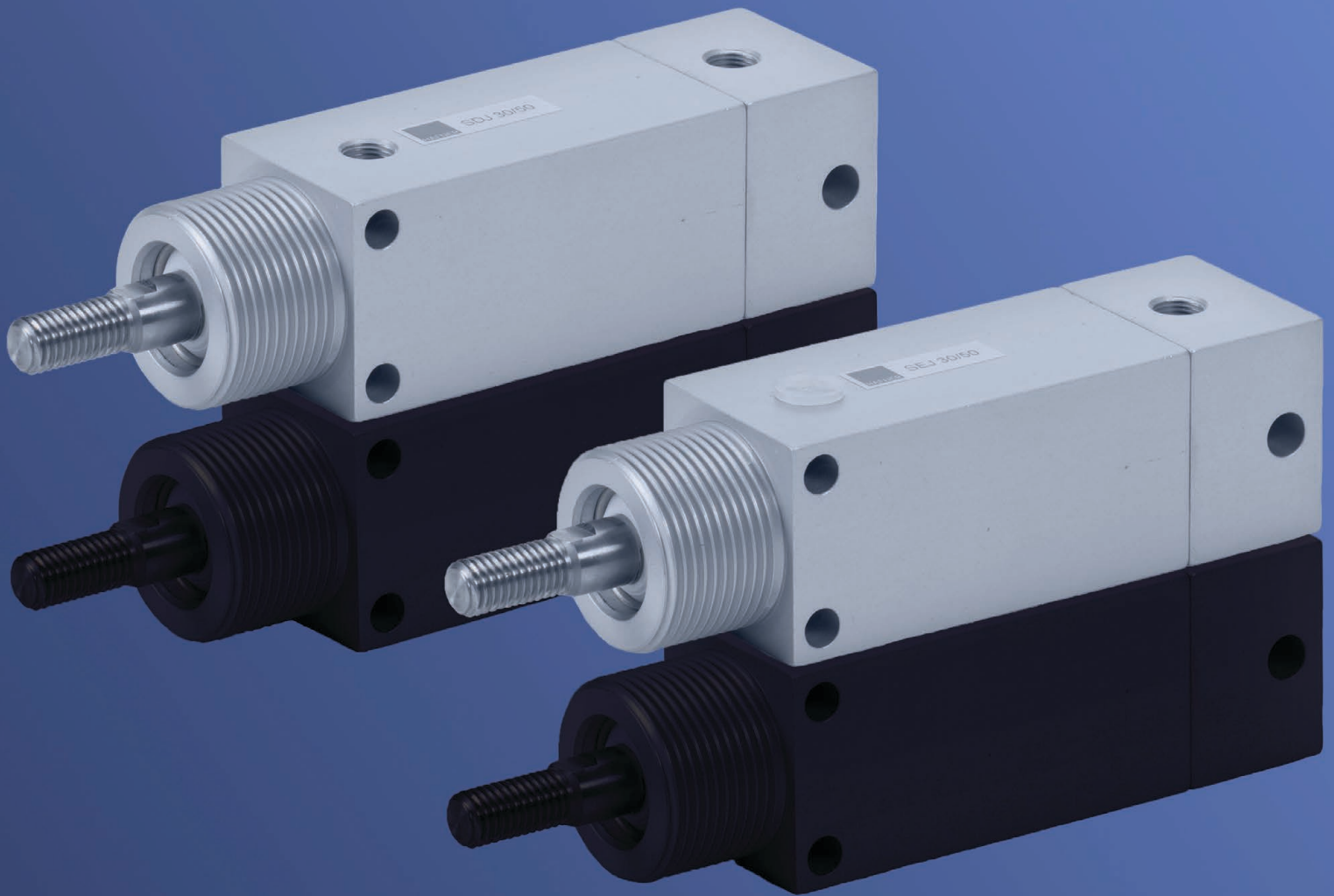

Prítlačné valce

Všeobecný opis	
Priemer piestu	Ø20 - Ø30 - Ø40 mm
Štandardný zdvih	10 - 20 - 30 - 50 - 75 - 100 - 125 - 150 mm
	Jednočinný
	Dvočinný
Pracovné médium	stlačený vzduch
Pracovný tlak	0,2 ... 10 bar
Teplota okolia	-20°C ... +80°C
	Pri teplotách pod 0°C je potrebné používať vhodne pripravený, suchý stlačený vzduch.
Variácie	SEJ (jednočinný) SDJ (dvočinný)
Použitý materiál	
Teleso valca	eloxovaný hliník
Kryt	eloxovaný hliník
Piest	hliník
Piestnica	nehrdzavejúca oceľ
Vodiace puzdro	plast - Iglidur D
Tesnenia	NBR

S	E	J	20	/	25
			PRIEMER		ZDVIH
			20		10
			30		20
			40		30
					50
					75
					100
					125
					150
			VERZIE		
			E	Jednočinný valec	
			D	Dvočinný valec	

SEJ/SDJ

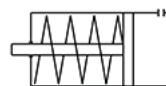

SEJ



SDJ

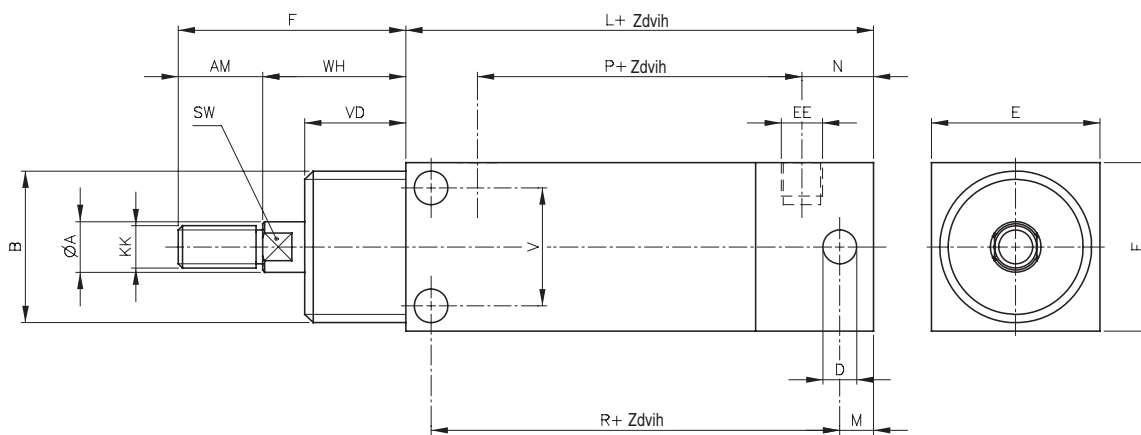

SEJ

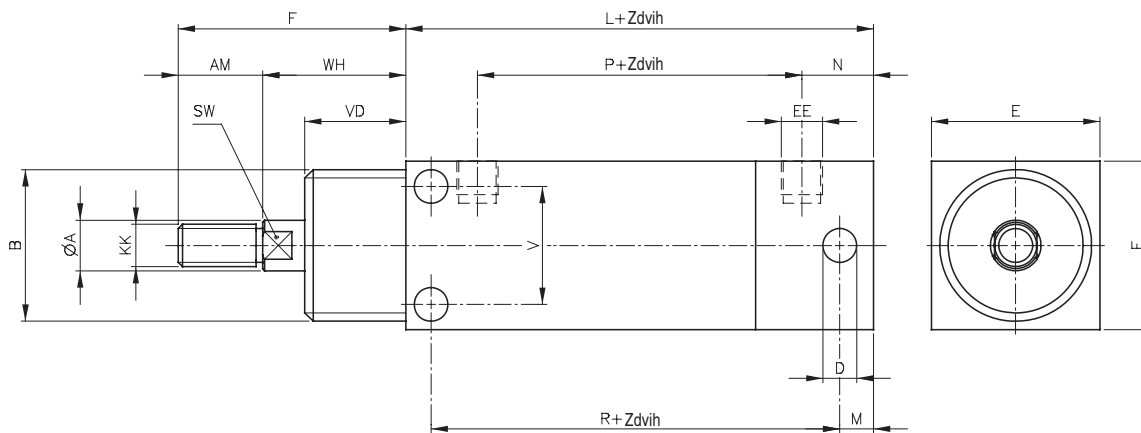

SDJ

Ø [mm]	A	B	D	E	F	L	M	N	P	R	V	AM	EE	KK	SW	VD	WH
Ø 20	10	M26x1,5	-	30	40	50	6	15	26	-	-	14	G1/8	M8	9	20	26
Ø 30	12	M36x2	7	40	54	61	8	17	27	47	28	20	G1/8	M10	10	24	34
Ø 40	12	M36x2	7	50	61,5	68,5	10	20,5	30	52	38	20	G1/8	M10	10	30	41,5



Tlmiče nárazov

Tlmiče nárazov

Všeobecný opis	
Štandardný zdvih	6 - 8 - 15 - 20 mm
Pracovné médium	stlačený vzduch
Teplota okolia	-10°C ... +70°C
	Pri teplotách pod 0°C je potrebné používať vhodne pripravený, suchý stlačený vzduch.
Variácie	SH, SH C

Použitý materiál	
Teleso valca	eloxovaný hliník
Kryt	eloxovaný hliník
Piest	hliník
Piestnica	nehrdzavejúca oceľ
Vodiace puzdro	plast - Iglidur D
Tesnenia	NBR

S	H	8	/	6	C
		10	/	8	MOŽNOSTI C Montované s viečkom
		14	/	15	
		20	/	20	

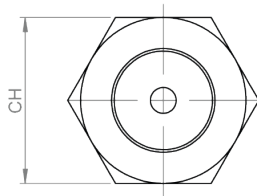

SH

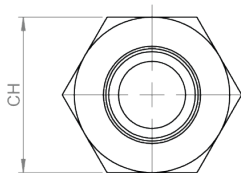
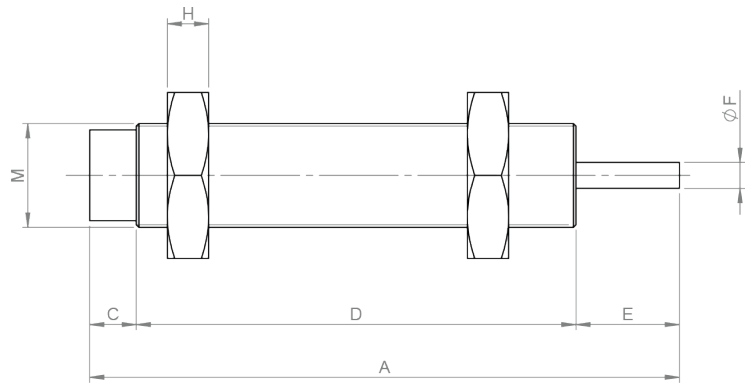

SHC

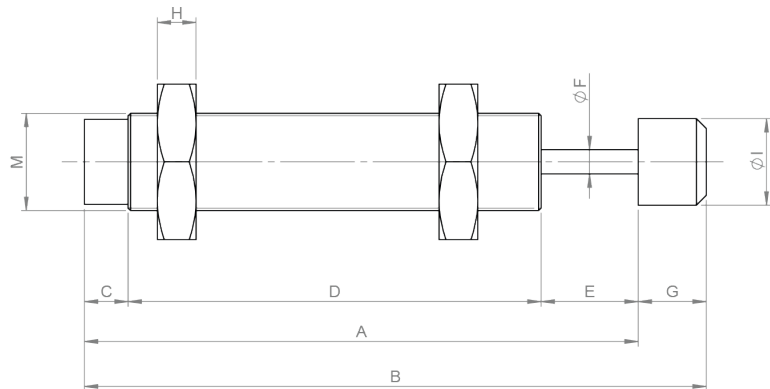

Zdvih	M	Max. rýchlosť	A	B	C	D	E	F	G	I	CH	H
6 mm	M8x1	1,2 m/s	46,5	55	5	35,5	6	2,8	8,5	6,5	11	3
8 mm	M10x1	1,5 m/s	53,5	62	5	40,5	8	3	8,5	8,5	13	3
15 mm	M14x1,5	1,5 m/s	90	102	8	67	15	3,5	12	12,2	19	6
20 mm	M20x1,5	2 m/s	114	128	9	85	20	5	14	17,8	26	8

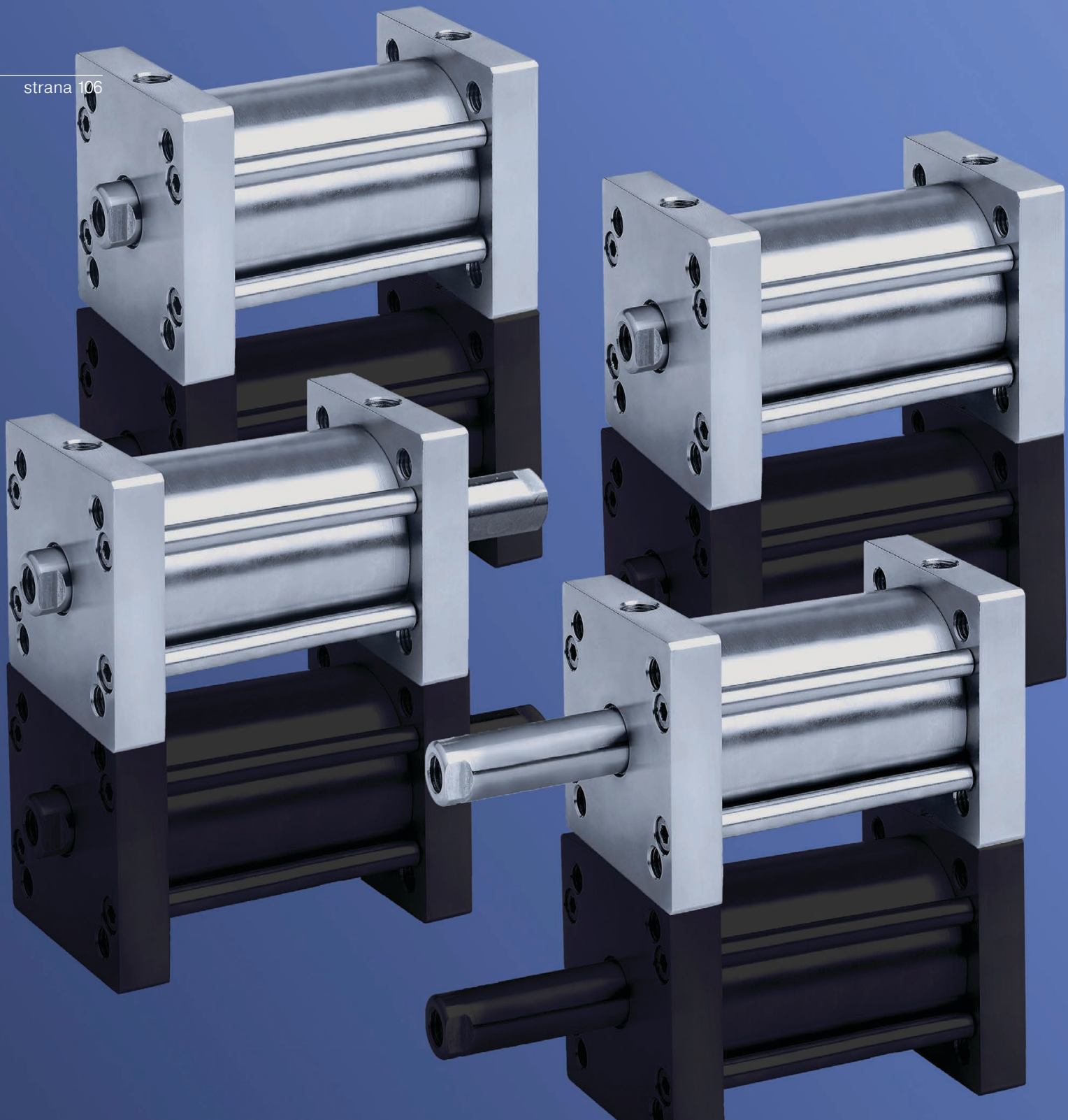

INOX

Všeobecný opis	
Priemer piestu	Ø20 - Ø25 - Ø32 - Ø40 - Ø50 - Ø63 - Ø80 - Ø100 - Ø125 - Ø160 - Ø200 mm
Štandardný zdvih	10 - 25 - 50 mm Jednočinný
	5 - 10 - 25 - 50 - 70 - 75 - 80 - 90 - 100 - 125 - 150 - 160 - 200 - 250 - 300 - 400 - 500 - 600 - 700 - 800 - 900 - 1000 mm Dvojčinný
Pracovné médium	stlačený vzduch
Pracovný tlak	Jednočinný: 1 ... 10 bar Dvojčinný: 2 ... 10 bar
Teplota okolia	0°C ... +80°C 0°C ... +150°C (v prevedení odolnom voči vysokým teplotám)
	Pri teplotách pod 0°C je potrebné používať vhodne pripravený, suchý stlačený vzduch.
Variácie	VENX, VEFX, VENXV, VEFXV (jednočinný) VINX/VIFX, VINTX, VBFX/VBNX, DIMX, RIMX/RIMOX, HIFX, HBFX (dvojčinný)

Použitý materiál		HIFX, HBFX
Teleso valca	nehrdzavejúca oceľ	nehrdzavejúca oceľ
Kryt	nehrdzavejúca oceľ	nehrdzavejúca oceľ
Piest	hliník	hliníkový tlakový odliatok
Piestnica	nehrdzavejúca oceľ	nehrdzavejúca oceľ
Vodiace puzdro	technopolymér	sintrovaný bronz
Tesnenia	polyuretán	polyuretán

Kruhové valce | ISO 6432

RIMX

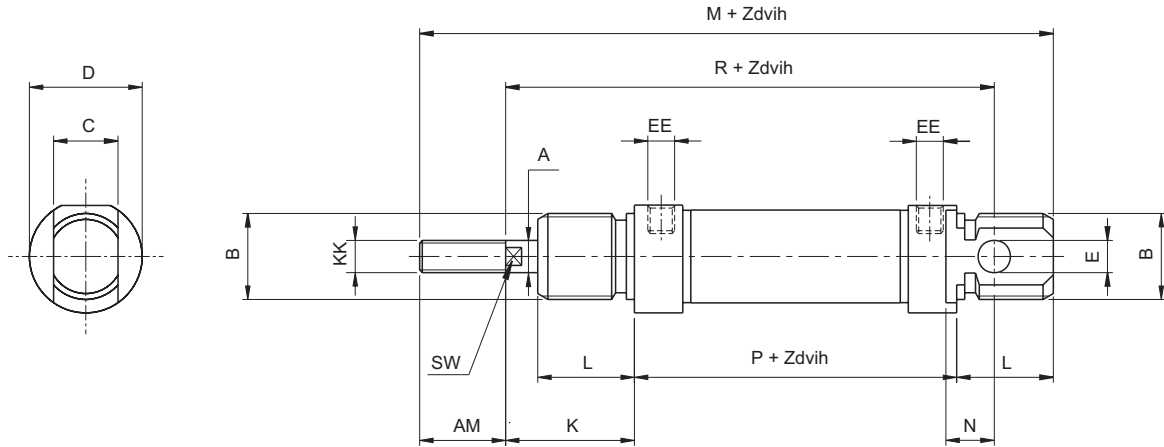
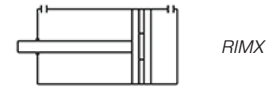

Ø [mm]	A	B	C	D	E	K	L	M	N	P	R	AM	EE	KK	SW
Ø16	6	M16x1,5	12	19	6	22	18	109	9	53	82	16	M5	M6	5
Ø20	8	M22x1,5	16	27	8	24	20	131	12	67	95	20	G1/8"	M8	7
Ø25	10	M22x1,5	16	30	8	28	22	140	12	68	104	22	G1/8"	M10x1,25	9

RIMOX

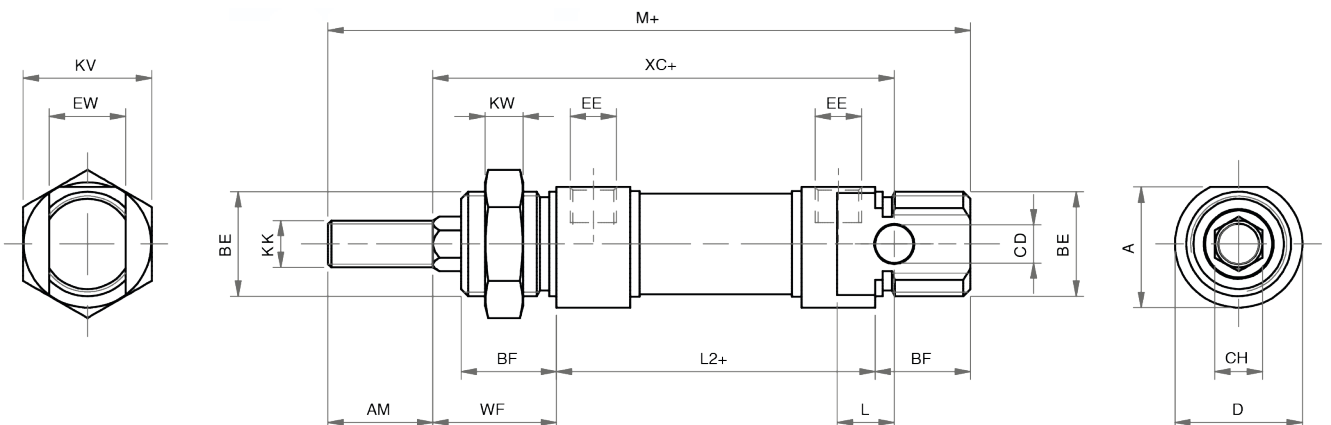
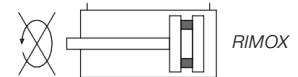

Ø [mm]	A	AM	BE	BF	CD	CH	D	EE	EW	KK	KV	KW	L	L2+	M+	WF	XC+
Ø16	18	16	M16x1,5	18	6	6	19	M5	12	M6	22	8	9	53	109	22	82
Ø20	25,5	20	M22x1,5	20	8	8	27	G1/8"	16	M8	27	11	12	67	131	24	95
Ø25	28,5	22	M22x1,5	22	8	10	30	G1/8"	16	M10x1,25	27	11	12	68	140	28	104

+ Prosíme, rátajte aj s pridaním dĺžky zdvihu!

Kruhové valce AFX/AJX

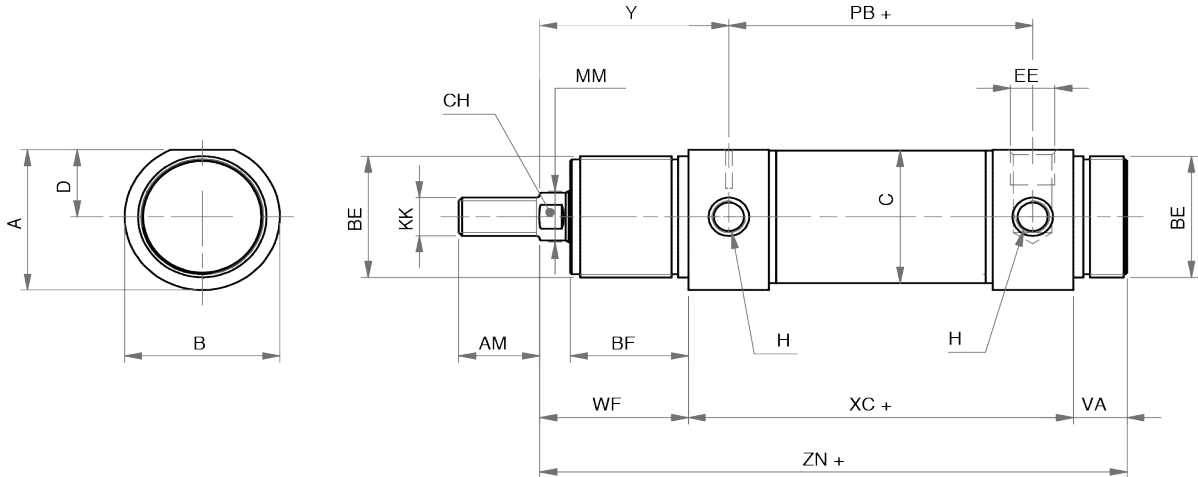
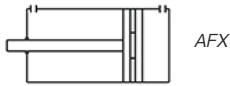

Ø [mm]	A	AM	B	BE	BF	C	CH	D	EE	H	KK	MM	PB+	VA	WF	XC+	Y	ZN+
Ø32	36,5	20	38	M30x1,5	30	33,6	10	17,5	G1/8	M8x1	M10x1,25	12	78	14	38	96	47	148
Ø40	44	24	46	M38x1,5	35	41,6	12	21	G1/4	M10x1	M12x1,25	16	89	16	45	113	57	174
Ø50	55	32	57	M45x1,5	38	52,4	16	26,5	G1/4	M12x1,5	M16x1,5	20	96	18	50	120	62	188
Ø63	67,5	32	70	M45x1,5	38	65,4	16	32,5	G3/8	M14x1,5	M16x1,5	20	98	18	50	124	63	192

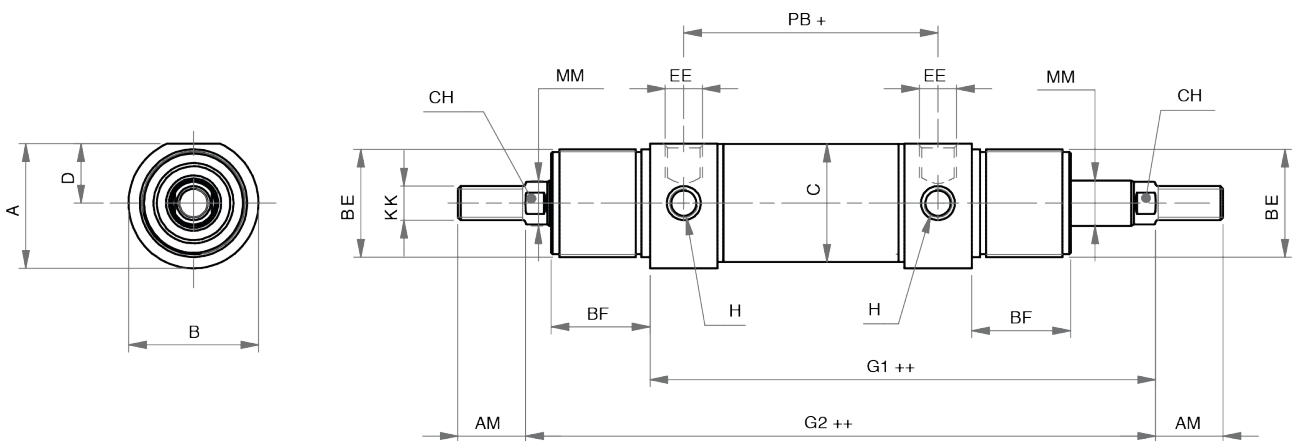
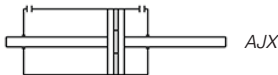

Ø [mm]	A	AM	B	BE	BF	C	CH	D	EE	G1	G2	H	KK	MM	PB+
Ø32	36,5	20	38	M30x1,5	30	33,6	10	17,5	G1/8	134	172	M8x1	M10x1,25	12	78
Ø40	44	24	46	M38x1,5	35	41,6	13	21	G1/4	158	203	M10x1	M12x1,25	16	89
Ø50	55	32	57	M45x1,5	38	52,4	17	26,5	G1/4	170	220	M12x1,5	M16x1,5	20	96
Ø63	67,5	32	70	M45x1,5	38	65,4	17	32,5	G3/8	174	224	M14x1,5	M16x1,5	20	98

+ Prosíme, rátajte aj s pridaním dĺžky zdvihu!

Kompaktné valce | ISO 21287

VENX/VEFX/VENVX/VEFVX

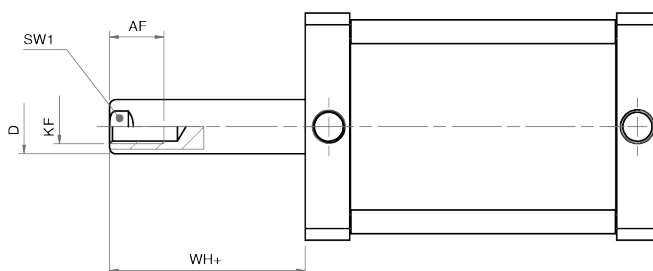
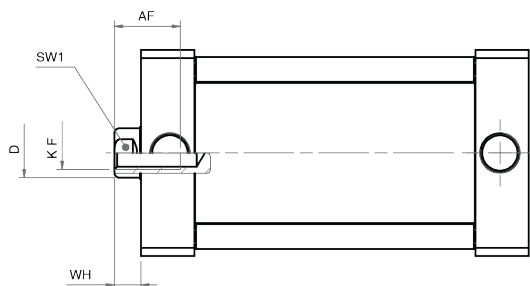
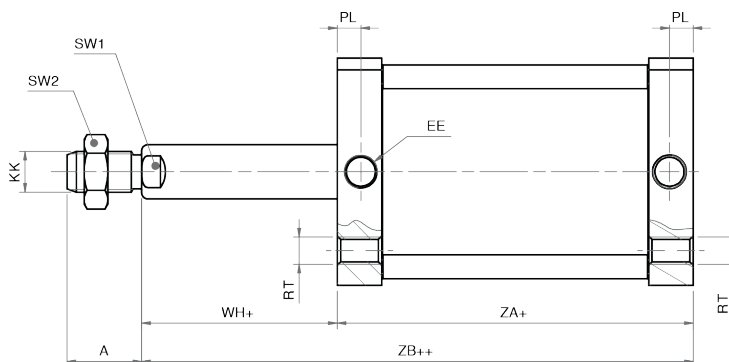
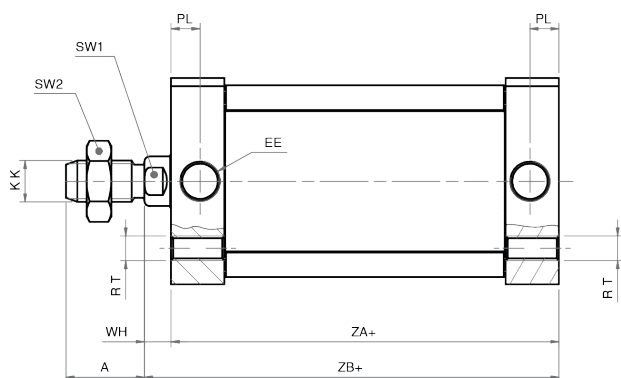
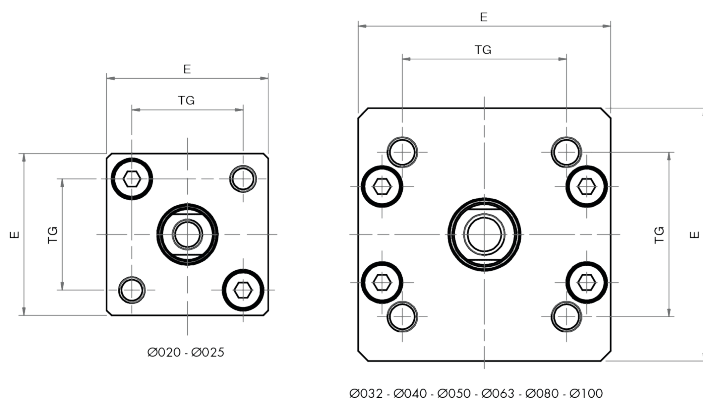
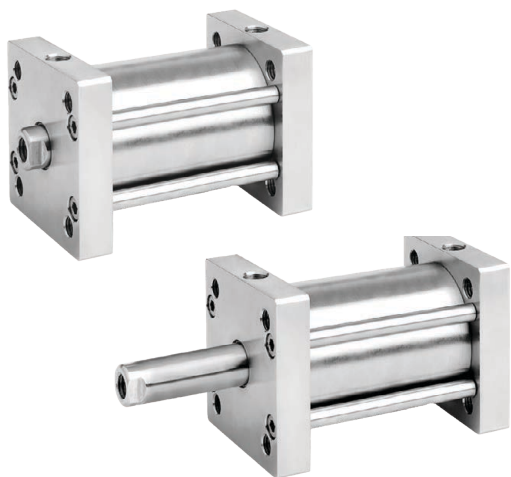

VENX/VEFX

VENVX/VEFVX

Ø [mm]	A	AF	D	E	EE	KF	KK	PL	RT	SW1	SW2	TG	WH	ZA+	ZB+
Ø20	16	10	10	32	M5	M6	M8	6	M5	8	13	22	6,5	47*	53,5*
Ø25	16	10	10	36	M5	M6	M8	6	M5	8	13	26	6	49*	55*
Ø32	19	12	12	50	G1/8	M8	M10x1,25	7	M6	10	17	32,5	6,5	44*	50,5*
Ø40	19	12	12	57	G1/8	M8	M10x1,25	7	M6	10	17	38	7	45*	52*
Ø50	22	16	16	67	G1/8	M10	M12x1,25	7	M8	13	19	46,5	8	45*	53*
Ø63	22	16	16	80	G1/8	M10	M12x1,25	7	M8	13	19	56,5	8	49*	57*
Ø80	28	20	20	96	G1/8	M12	M16x1,5	7,5	M10	17	24	72	10	54*	64*
Ø100	28	25	25	116	G1/8	M12	M16x1,5	7,5	M10	22	24	89	10	67*	77*

*VENX, VEFX v prípade zdvíhu 50 mm: +10 mm pre Ø20, +20 mm pre Ø25-Ø63, +30 mm pre Ø80-Ø100
 VENVX, VEFVX v prípade zdvíhu 50 mm: +10 mm pre Ø20-Ø25-Ø32-Ø63, +20 mm pre Ø80-Ø100
 + Prosíme, rátať aj s pridaním dĺžky zdvíhu!

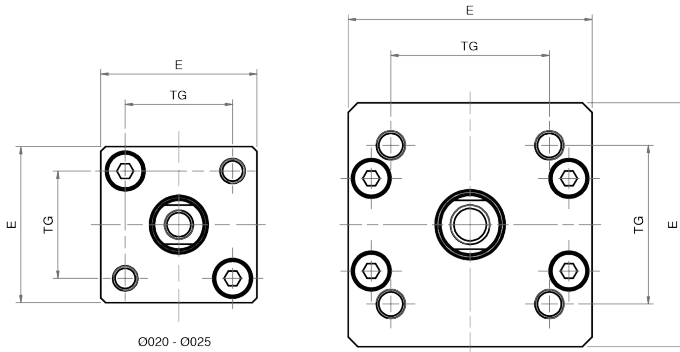
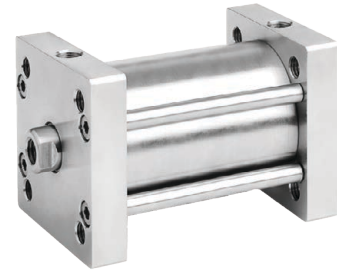
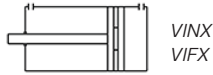

Ø020 - Ø025

Ø032 - Ø040 - Ø050 - Ø063 - Ø080

Ø100 - Ø125 - Ø160 - Ø200

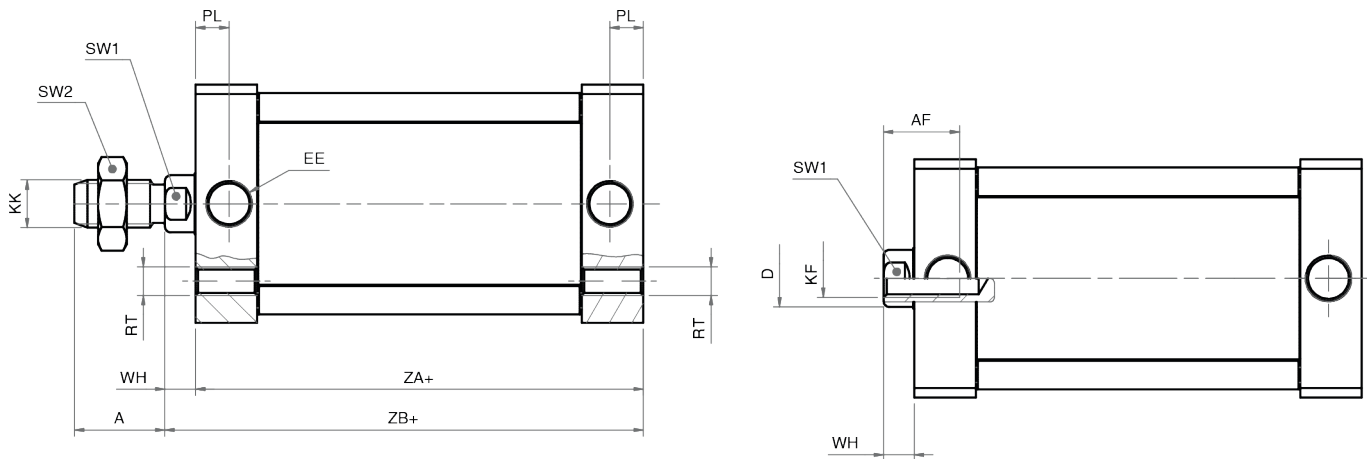

Ø [mm]	A	AF	D	E	EE	KF	KK	PL	RT	SW1	SW2	TG	WH	ZA+	ZB+
Ø20	16	10	10	32	M5	M6	M8	6	M5	8	13	22	6,5	37	43,5
Ø25	16	10	10	36	M5	M6	M8	6	M5	8	13	26	6	39	45
Ø32	19	12	12	50	G1/8	M8	M10x1,25	7	M6	10	17	32,5	6,5	44	50,5
Ø40	19	12	12	57	G1/8	M8	M10x1,25	7	M6	10	17	38	7	45	52
Ø50	22	16	16	67	G1/8	M10	M12x1,25	7	M8	13	19	46,5	8	45	53
Ø63	22	16	16	80	G1/8	M10	M12x1,25	7	M8	13	19	56,5	8	49	57
Ø80	28	20	20	96	G1/8	M12	M16x1,5	7,5	M10	17	24	72	10	54	64
Ø100	28	20	25	116	G1/8	M12	M16x1,5	7,5	M10	22	24	89	10	67	77
Ø125	54	25	30	140	1/4"	M14	M27x2	10	M12	28	41	110	10	78	88
Ø160	72	30	40	180	3/8"	M20	M36x2	12	M16	36	55	140	12	87	99
Ø200	72	30	40	220	3/8"	M20	M36x2	12	M16	36	55	175	12	87	99

+ Prosíme, rátajte aj s pridaním dĺžky zdvihu!

Kompaktné valce | ISO 21287

VINTX

strana 112

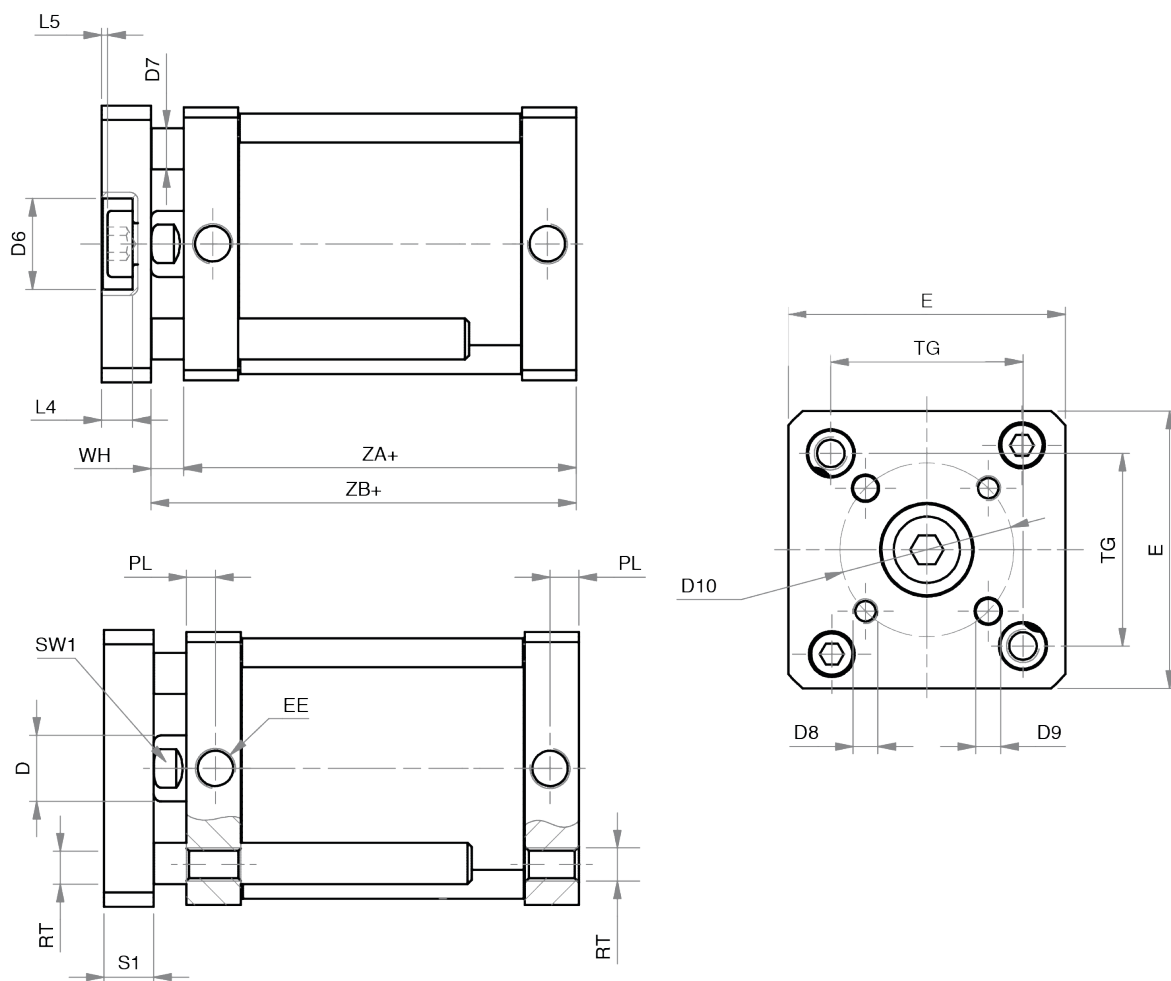
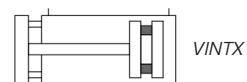

Ø [mm]	D	D6	D7	D8	D9	D10	E	EE	SW1	L4	L5	PL	RT	S1	TG	WH	ZA+	ZB+
Ø20	10	11	6	M4	4	17	32	M5	8	5	1	6	M5	8	22	6,5	37	43,5
Ø25	10	14	6	M5	5	22	36	M5	8	5	1	6	M5	8	26	6	39	45
Ø32	12	17	6	M5	5	28	50	G1/8	10	6,5	1,5	7	M6	10	32,5	6,5	44	50,5
Ø40	12	17	8	M5	5	33	57	G1/8	10	6,5	1,5	7	M6	10	38	7	45	52
Ø50	16	22	10	M6	6	42	67	G1/8	13	7,5	1,5	7	M8	12	46,5	8	45	53
Ø63	16	22	10	M6	6	50	80	G1/8	13	7,5	1,5	7	M8	12	56,5	8	49	57
Ø80	20	28	12	M8	8	65	96	G1/8	17	9	2	7,5	M10	14	72	10	54	64
Ø100	25	30	14	M10	10	80	116	G1/8	22	10	3	7,5	M10	14	89	10	67	77

+ Prosíme, rátajte aj s pridaním dĺžky zdvihu!

Kompakt hengerek | ISO 21287 VBFX/VBNX

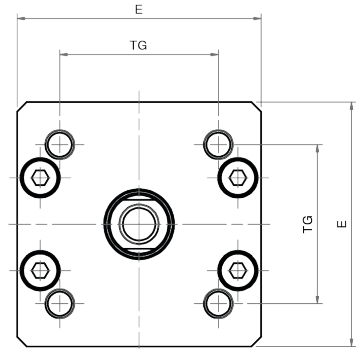
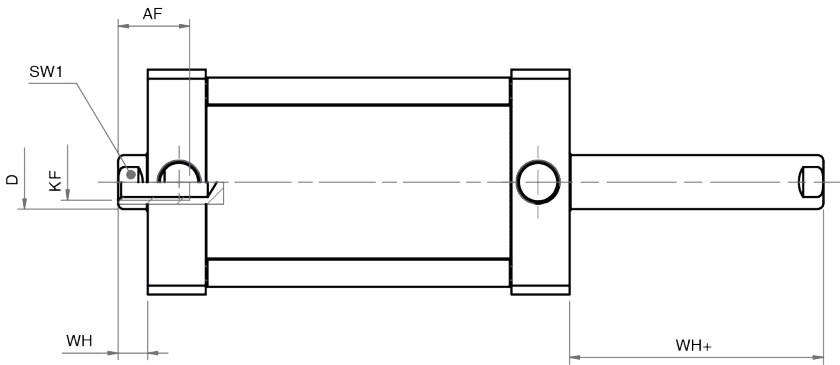
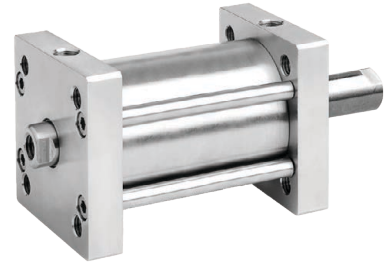
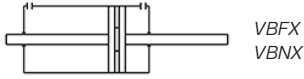

Ø032 - Ø040 - Ø050 - Ø063 - Ø080
Ø100 - Ø125 - Ø160 - Ø200

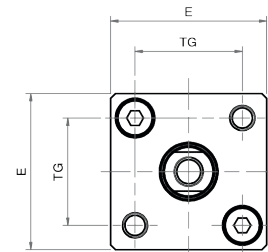
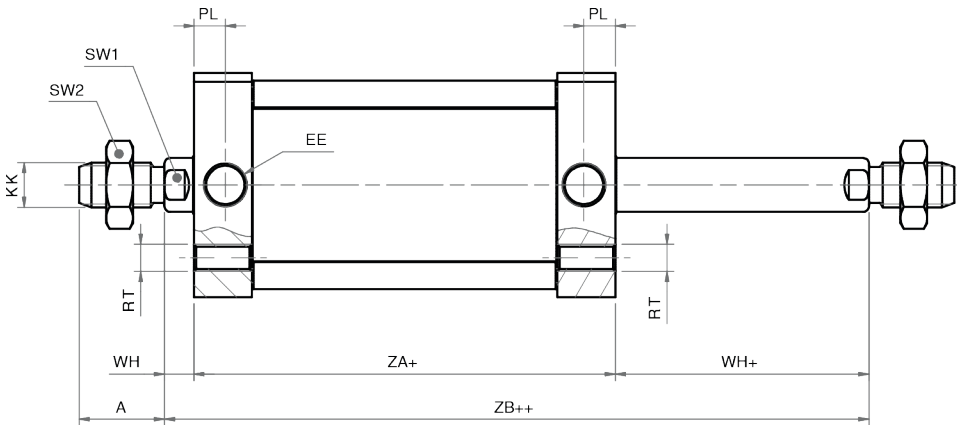

Ø020 - Ø025

Ø [mm]	A	AF	D	E	EE	KF	KK	PL	RT	SW1	SW2	TG	WH	WH+	ZA+	ZB++
Ø20	16	10	10	32	M5	M6	M8	6	M5	8	13	22	6,5	6,5	37	43,5
Ø25	16	10	10	36	M5	M6	M8	6	M5	8	13	26	6	6	39	45
Ø32	19	12	12	50	G1/8	M8	M10x1,25	7	M6	10	17	32,5	6,5	6,5	44	50,5
Ø40	19	12	12	57	G1/8	M8	M10x1,25	7	M6	10	17	38	7	7	45	52
Ø50	22	16	16	67	G1/8	M10	M12x1,25	7	M8	13	19	46,5	8	8	45	53
Ø63	22	16	16	80	G1/8	M10	M12x1,25	7	M8	13	19	56,5	8	8	49	57
Ø80	28	20	20	96	G1/8	M12	M16x1,5	7,5	M10	17	24	72	10	10	54	64
Ø100	28	20	25	116	G1/8	M12	M16x1,5	7,5	M10	22	24	89	10	10	67	77
Ø125	54	25	30	140	1/4"	M14	M27x2	10	M12	28	41	110	10	10	78	88
Ø160	72	30	40	180	3/8"	M20	M36x2	12	M16	36	55	140	12	12	87	99
Ø200	72	30	40	220	3/8"	M20	M36x2	12	M16	36	55	175	12	12	87	99

+ Prosíme, rátajte aj s pridaním dĺžky zdvihu!

Normalizované valce | ISO 15552

HIFX

strana 114

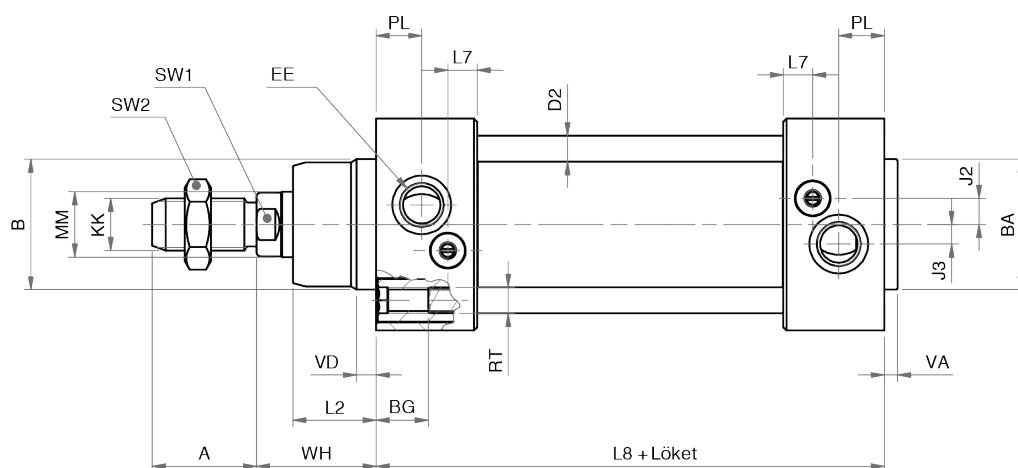
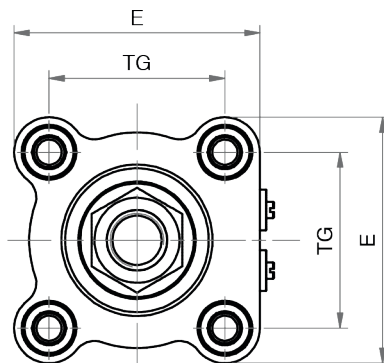
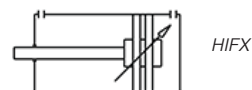

Ø [mm]	A	B	BA	BG	D2	E	EE	J2	J3	KK	L2
Ø32	32	30	30	16	6	48	G1/8	6,6	5,3	M10x1,25	18
Ø40	24	35	35	16	6	52	G1/4	8,5	5	M12x1,25	22
Ø50	32	40	40	16	8	65	G1/4	8	6	M16x1,5	25,5
Ø63	32	45	45	16	8	75	G3/8	10	6,5	M16x1,5	26
Ø80	40	45	45	18	10	95	G3/8	8	8	M20x1,5	32
Ø100	40	55	55	18	10	115	G1/2	15	7	M20x1,5	38
Ø125	54	60	60	20	12	140	G1/2	13	7	M27x2	46

Ø [mm]	L7	L8+	MM	PL	RT	SW1	SW2	TG	VA	VD	WH
Ø32	7,2	94	12	13	M6	10	17	32,5	4	5	26
Ø40	9,2	105	16	14	M6	13	19	38	4	5	30
Ø50	9	106	20	14	M8	17	24	46,5	4	6	37
Ø63	9,5	121	20	16	M8	17	24	56,5	4	6	37
Ø80	11	128	25	16	M10	22	30	72	4	7	46
Ø100	12	138	25	18	M10	22	30	89	4	7	51
Ø125	12	160	32	18	M12	27	41	110	6	10	65

+ Prosíme, rátajte aj s pridaním dĺžky zdvihu!

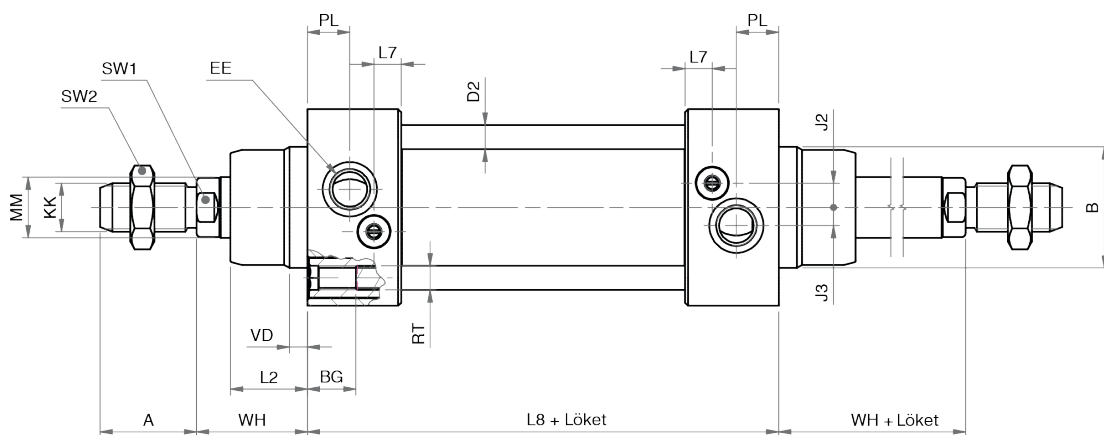
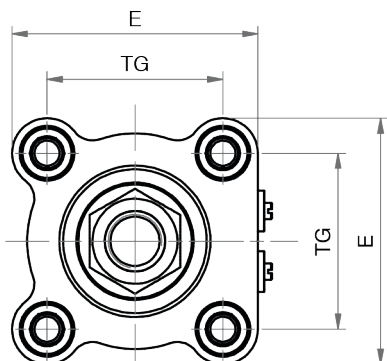
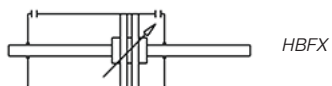

Ø [mm]	A	B	BA	BG	D2	E	EE	J2	J3	KK	L2
Ø32	22	30	30	16	6	48	G1/8	6,6	5,3	M10x1,25	18
Ø40	24	35	35	16	6	52	G1/4	8,5	5	M12x1,25	22
Ø50	32	40	40	16	8	65	G1/4	8	6	M16x1,5	25,5
Ø63	32	45	45	16	8	75	G3/8	10	6,5	M16x1,5	26
Ø80	40	45	45	18	10	95	G3/8	8	8	M20x1,5	32
Ø100	40	55	55	18	10	115	G1/2	15	7	M20x1,5	38
Ø125	54	60	60	20	12	140	G1/2	13	7	M27x2	46

Ø [mm]	L7	L8+	MM	PL	RT	SW1	SW2	TG	VD	WH	WH+
Ø32	7,2	94	12	13	M6	10	17	32,5	5	26	26
Ø40	9,2	105	16	14	M6	13	19	38	5	30	30
Ø50	9	106	20	14	M8	17	24	46,5	6	37	37
Ø63	9,5	121	20	16	M8	17	24	56,5	6	37	37
Ø80	11	128	25	16	M10	22	30	72	7	46	46
Ø100	12	138	25	18	M10	22	30	89	7	51	51
Ø125	12	160	32	18	M12	27	41	110	10	65	65

+ Prosíme, rátajte aj s pridaním dĺžky zdvihu!

Svorníkové valce | ISO 15552 DIMX

strana 116

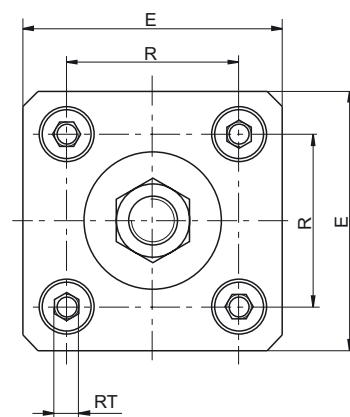
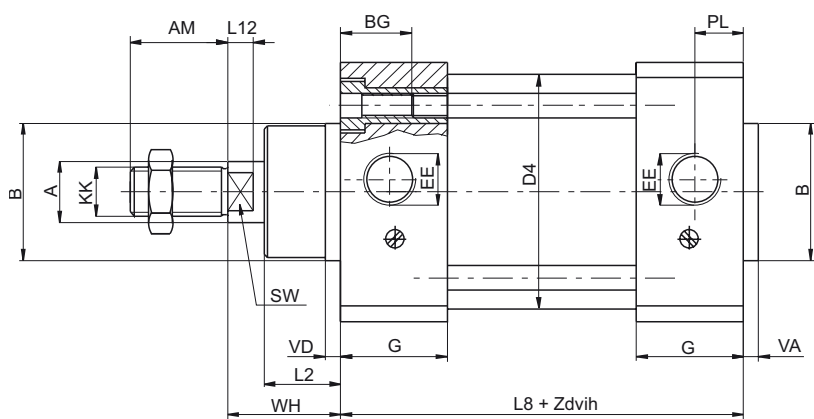
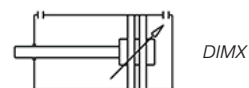

Ø [mm]	A	AM	B	BG	E	EE	G	KK	L2	L8	L12	PL	R	RT	SW	VA	VD	WH
Ø160	40	72	65	24	182	G3/4	59	M36x2	38	180	12	27	140	M16	38	6	6	80
Ø200	40	72	75	24	222	G3/4	61	M36x2	55	180	12	35	175	M16	38	6	6	95

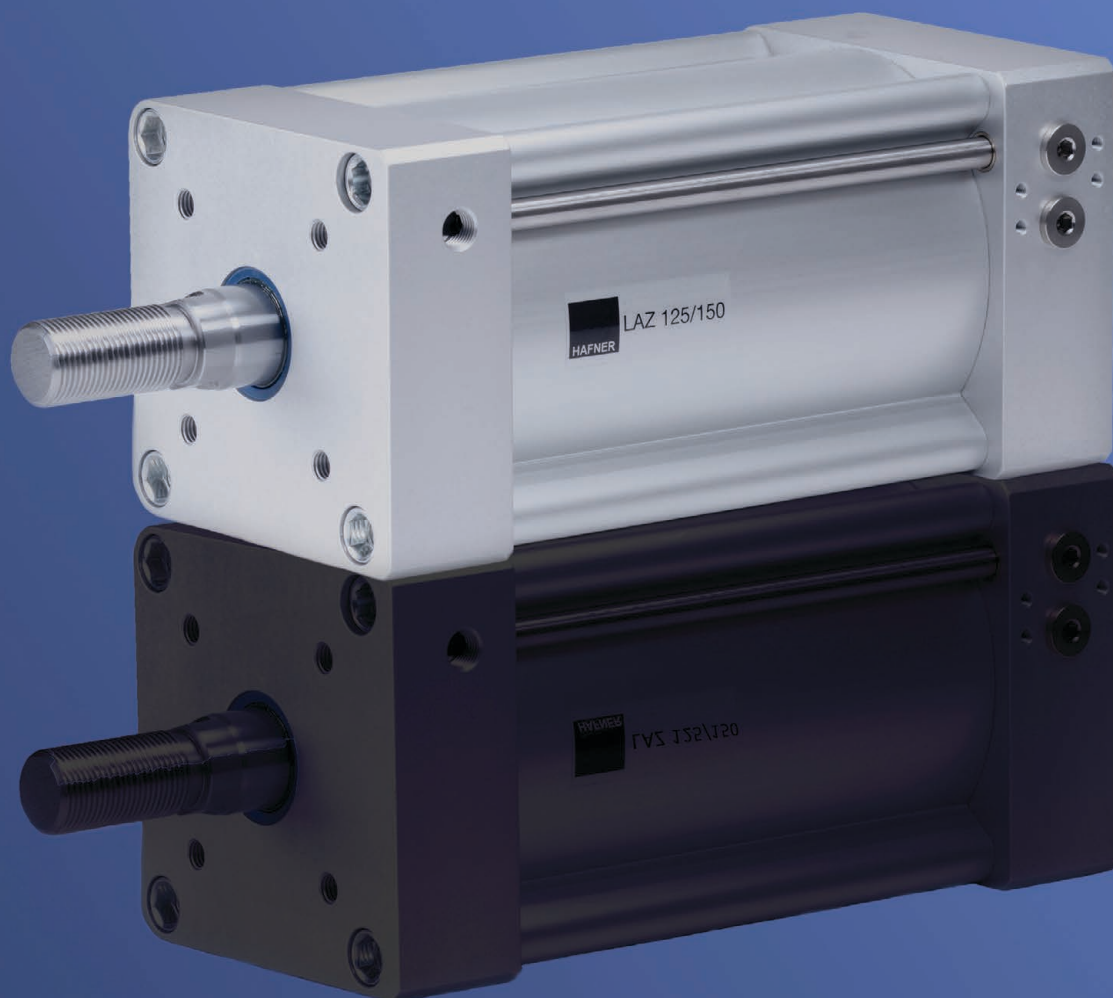

Valce k nožovým posúvačom

Valce k nožovým posúvačom

strana 118

Všeobecný opis	
Priemer piestu	Ø80 - Ø100 - Ø125 - Ø160 - Ø200 - Ø250 - Ø320 mm
Štandardný zdvih	25 - 50 - 80 - 100 - 125 - 160 - 200 - 250 - 320 - 400 - 500 - 600 - 700 - 800 - 900 - 1000 mm
Pracovné médium	stlačený vzduch
Pracovný tlak	1 ... 10 bar
Teplota okolia	-20°C ... +80°C
Pri teplotách pod 0°C je potrebné používať vhodne pripravený, suchý stlačený vzduch.	

L	A	Z	80	/	200
			PRIEMER		ZDVIH
			80		25
			100		50
			125		80
			160		100
			200		125
			250		160
			320		200
					250
					320
					400
					500
					600
					700
					800
					900
					1000

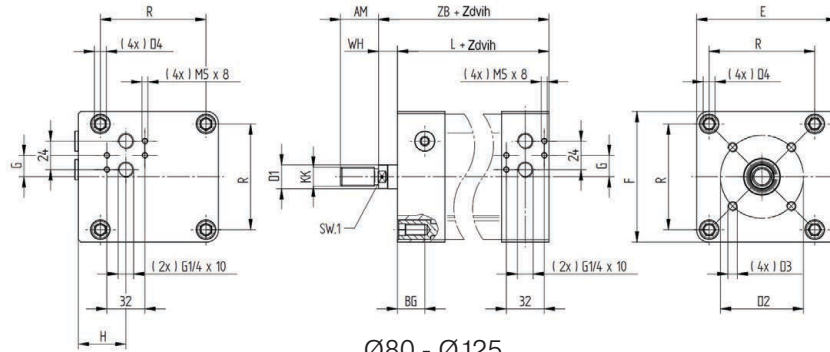
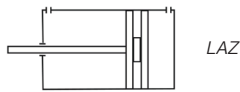

Ø80 - Ø125

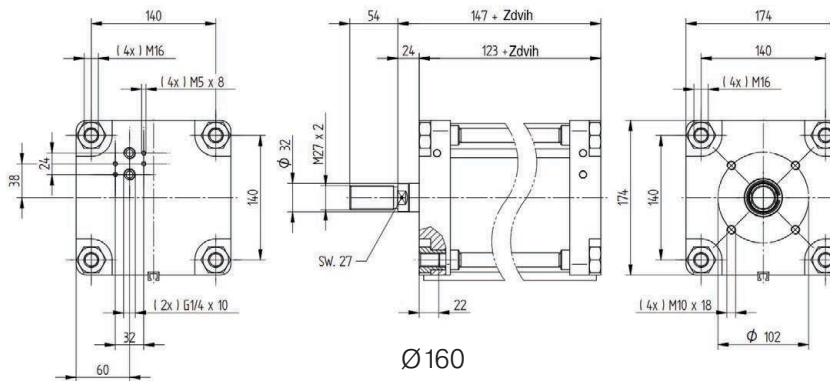

Ø160

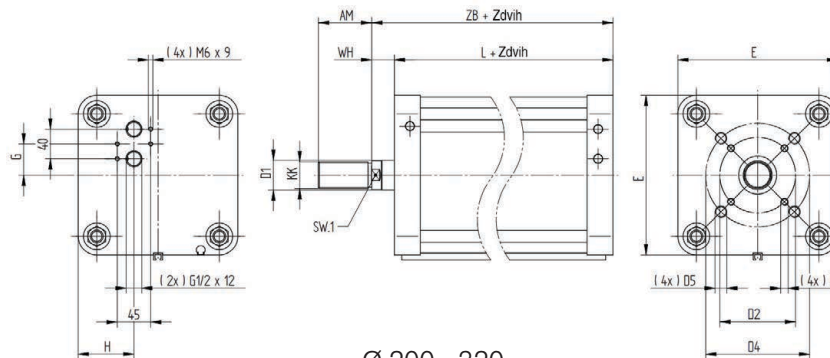

Ø200 - 320

Ø [mm]	AM	D1	KK	SW.1	D2	D3	D4	BG	R	D5	E	F	G	H	WH	L	ZB
Ø 80	32	Ø20	M16x1,5	17	Ø70	M8x15	M10	22	72	-	100	90	8	35	16	114	130
Ø 100	32	Ø20	M16x1,5	17	Ø70	M8x15	M10	22	89	-	118	110	18	40	16	118	134
Ø 125	54	Ø32	M27x2	27	Ø102	M10x18	M12	26	110	-	140	134	28	45	24	138	162
Ø 200	72	Ø40	M36x2	36	Ø102	M10x20	Ø140	-	-	M16x25	215	-	-	75	30	123	153
Ø 250	72	Ø40	M36x2	36	Ø102	M10x20	Ø140	-	-	M16x25	265	-	-	80	30	138	168
Ø 320	72	Ø40	M36x2	36	Ø102	M10x20	Ø140	-	-	M16x25	340	-	-	100	30	135	168

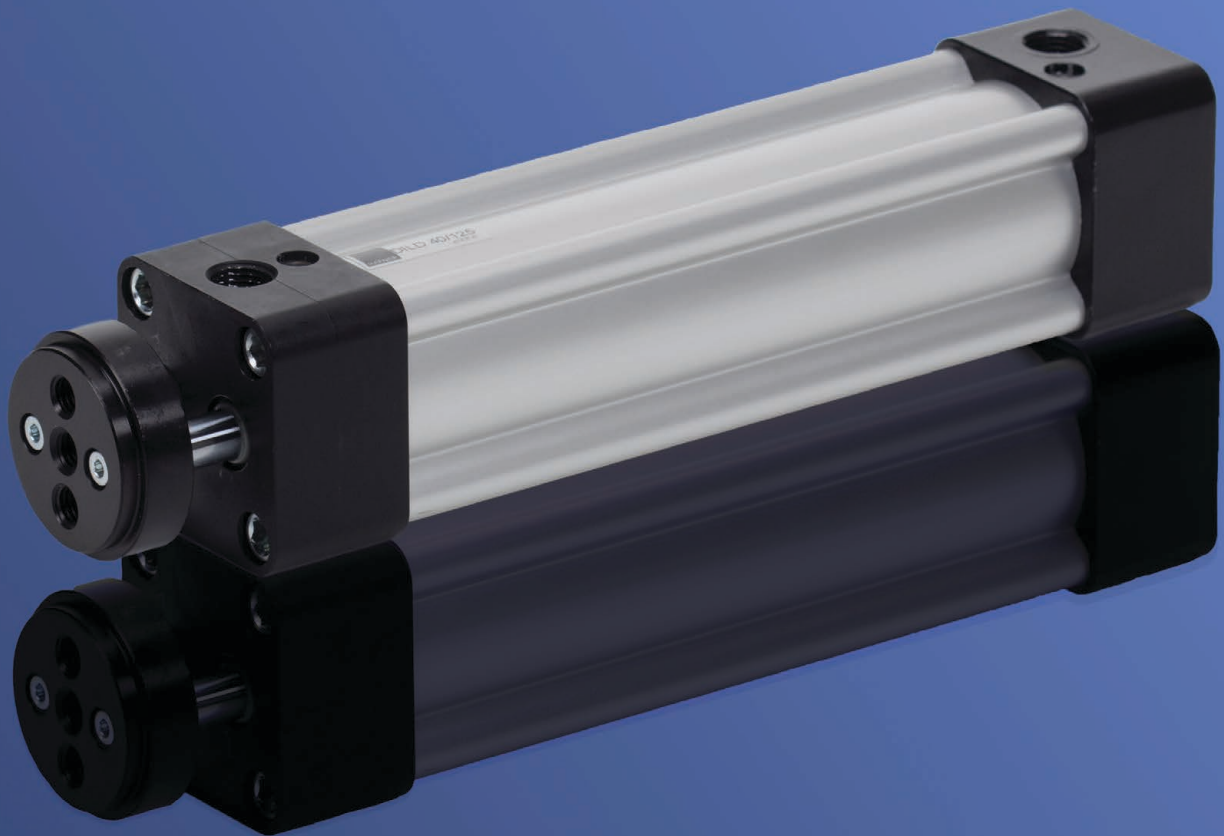

Valce s dvojitou piestnicou

Valce s dvojitou piestnicou

Všeobecný opis	
Priemer piestu	Ø32 - Ø40 - Ø50 - Ø63 - Ø80 - Ø100 mm
Štandardný zdvih	25 - 50 - 80 - 100 - 125 - 160 - 200 - 250 - 320 - 400 - 500 mm Ø32 - Ø50 mm Ø63 mm Ø80 - Ø100 mm
Pracovné médium	stlačený vzduch
Pracovný tlak	1 ... 10 bar
Teplota okolia	-20°C ... +80°C
	Pri teplotách pod 0°C je potrebné používať vhodne pripravený, suchý stlačený vzduch.

Použitý materiál	
Teleso valca	eloxovaný hliník
Kryt	hliníkový tlakový odliatok
Piest	hliník
Piestnica	tvrd chrómovaná oceľ
Vodiace puzdro	sintrovaný bronz
Tesnenia	polyuretán, NBR

D	I	F	D	50	/	100	Ex
				PRIEMER		ZDVIH	MOŽNOSTI
				32		25	Ex S certifikátom ATEX
				40		50	
				50		80	
				63		100	
				80		125	
				100		160	
						200	
						250	
						320	
						400	
						500	
VERZIE							
I Dvojčinný valec							
B Dvojčinný valec, priebežná piestnica							

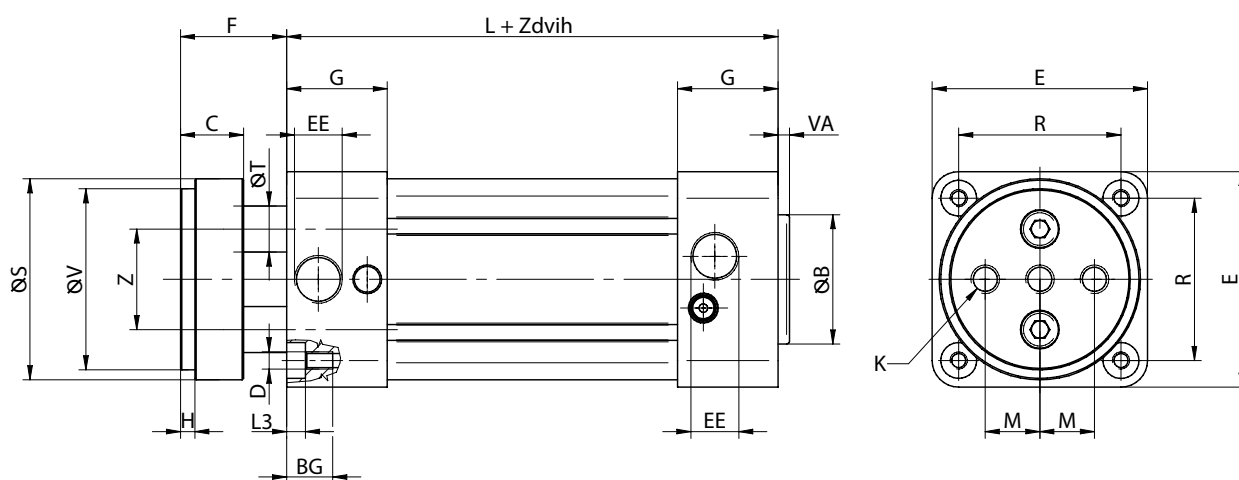
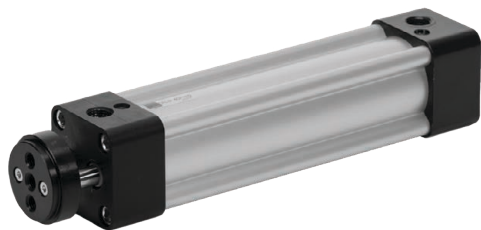
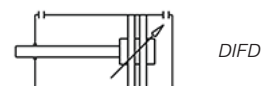

\emptyset [mm]	B	F	E	H	C	K	M	S	T	V	Z	VA	L	BG	D	R	EE	L3
$\emptyset 32$	30	26	47	4	15	M6	9,5	35	8	32	18	4	94	16	M6	32,5	G1/8	5
$\emptyset 40$	35	30	53	4	15	M8	11,25	45	10	40	22	4	105	16	M6	38	G1/4	5
$\emptyset 50$	40	37	65	5	18	M8	15	55	12	50	26	4	106	16	M8	46,5	G1/4	5
$\emptyset 63$	45	37	75	5	22	M10	19	70	16	63	35	4	121	16	M8	56,5	G3/8	5
$\emptyset 80$	45	46	95	5	22	M12	25	85	20	80	40	4	128	17	M10	72	G3/8	6,5
$\emptyset 100$	55	51	115	5	22	M12	35	105	20	100	50	4	138	17	M10	89	G1/2	6,5

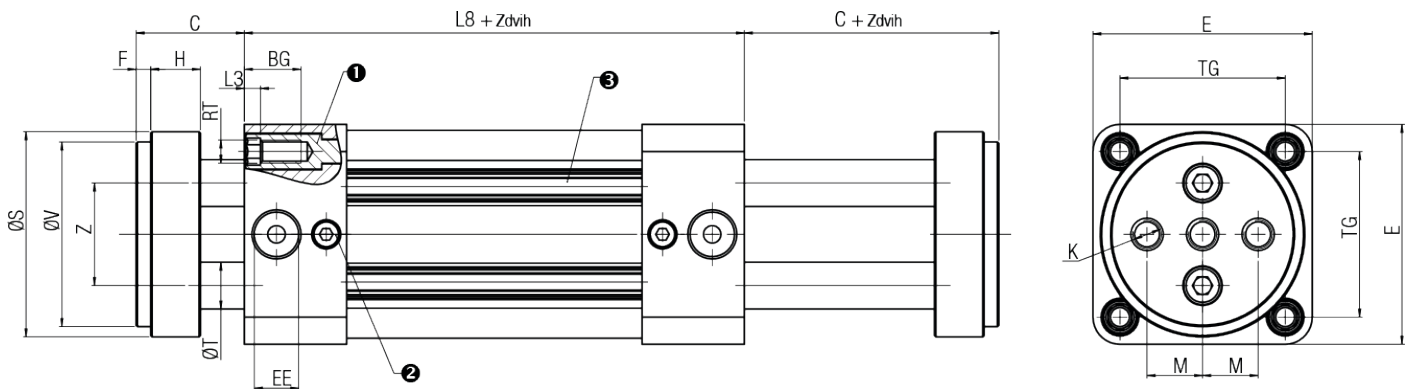
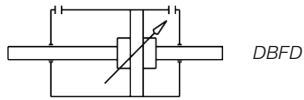

Ø [mm]	Ø Bd11	C	E	F	H	K	M	S	T	V	Z	F1	VA	L2
Ø32	30	26	47	4	15	M6	9,5	35	8	32	18	48	4	20
Ø40	35	30	53	4	15	M8	11,25	45	10	40	22	54	4	22
Ø50	40	37	65	5	18	M8	15	55	12	50	26	69	4	28
Ø63	45	37	75	5	22	M10	19	70	16	63	35	69	4	28
Ø80	45	46	95	5	22	M12	25	85	20	80	40	86	4	34
Ø100	55	51	115	5	22	M12	35	105	20	100	50	91	4	38

Ø [mm]	WH	MM	SW	KK	L8	BG	RT	E	TG	EE	PL	L3	ZM
Ø32	26	12	10	M10x1,25	94	16	M6	47	32,5	G1/8	14	5	146
Ø40	30	16	13	M12x1,25	105	16	M6	53	38	G1/4	16	5	165
Ø50	37	20	17	M16x1,5	106	16	M8	65	46,5	G1/4	21	5	180
Ø63	37	20	17	M16x1,5	121	16	M8	75	56,5	G3/8	22	5	195
Ø80	46	25	22	M20x1,5	128	18	M10	95	72	G3/8	23	6	220
Ø100	51,5	25	22	M20x1,5	138	18	M10	115	89	G1/2	26	6	240

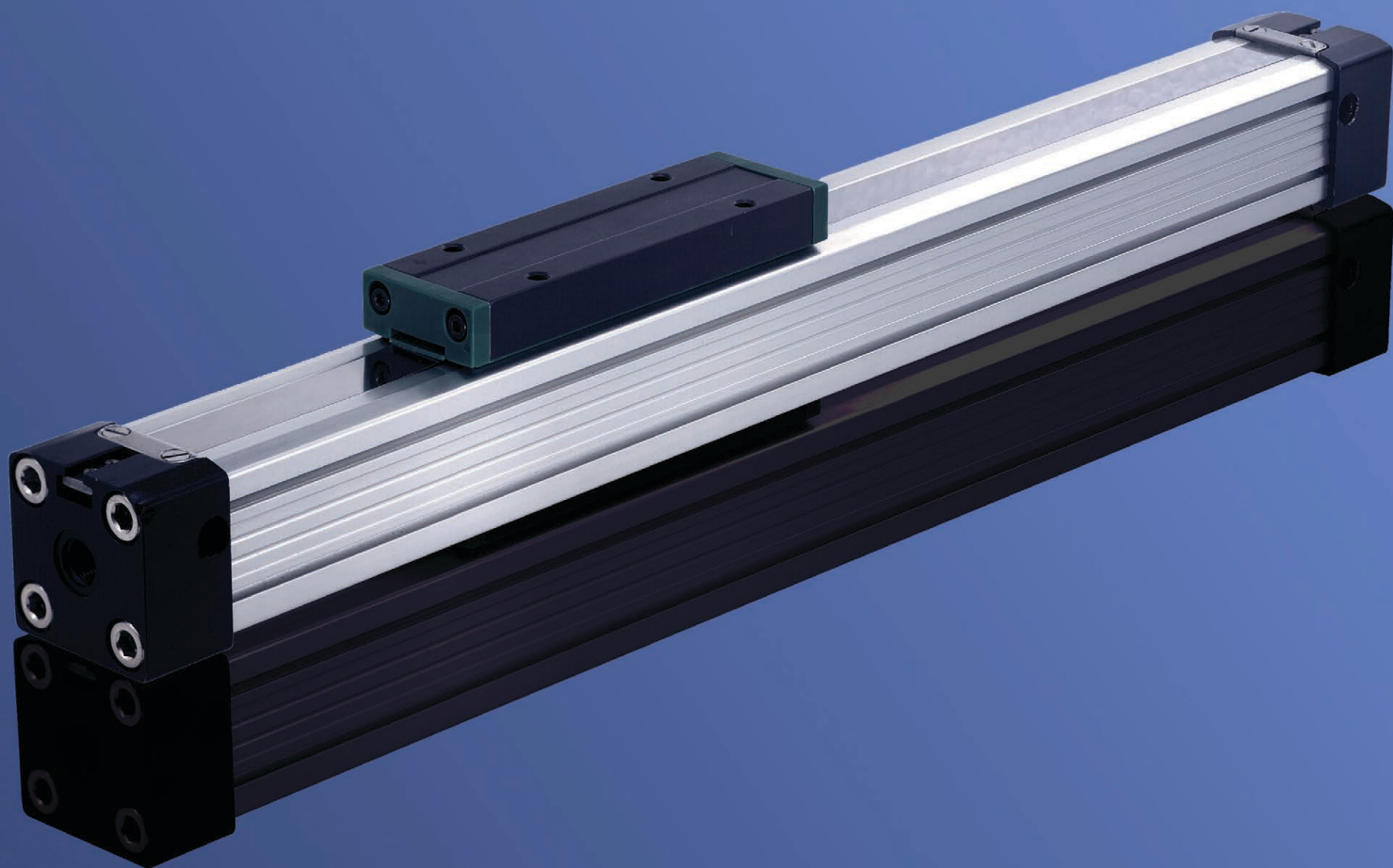

Bezpiestnicové valce

Všeobecný opis	
Priemer piestu	Ø16 - Ø25 - Ø32 - Ø40 - Ø50 - Ø63 mm
Štandardný zdvih	100 - 3300 - 4400 - 5700 mm (po 1 mm) Ø16 mm (PLK, PLG) Ø16 mm (PL, PLF) Ø25 - Ø63 mm (PL, PLF, PLK, PLG, PLR, PLS)
Pracovné médium	stlačený vzduch
Pracovný tlak	0,5 ... 8 bar
Teplota okolia	-10°C ... +80°C -10°C ... +55°C (PLS) Pri teplotách pod 0°C je potrebné používať vhodne pripravený, suchý stlačený vzduch.
Variácie	PL, PLF, PLK, PLG, PLR, PLS (pneumaticky ovládané)
Použitý materiál	
Teleso valca	eloxovaný hliník
Kryt	eloxovaný hliník
Piest	eloxovaný hliník
Tesnenia	syntetický materiál odolný voči olejom ($V < 1\text{m/s}$ (NBR) $V \geq 1\text{m/s}$ (VITON))

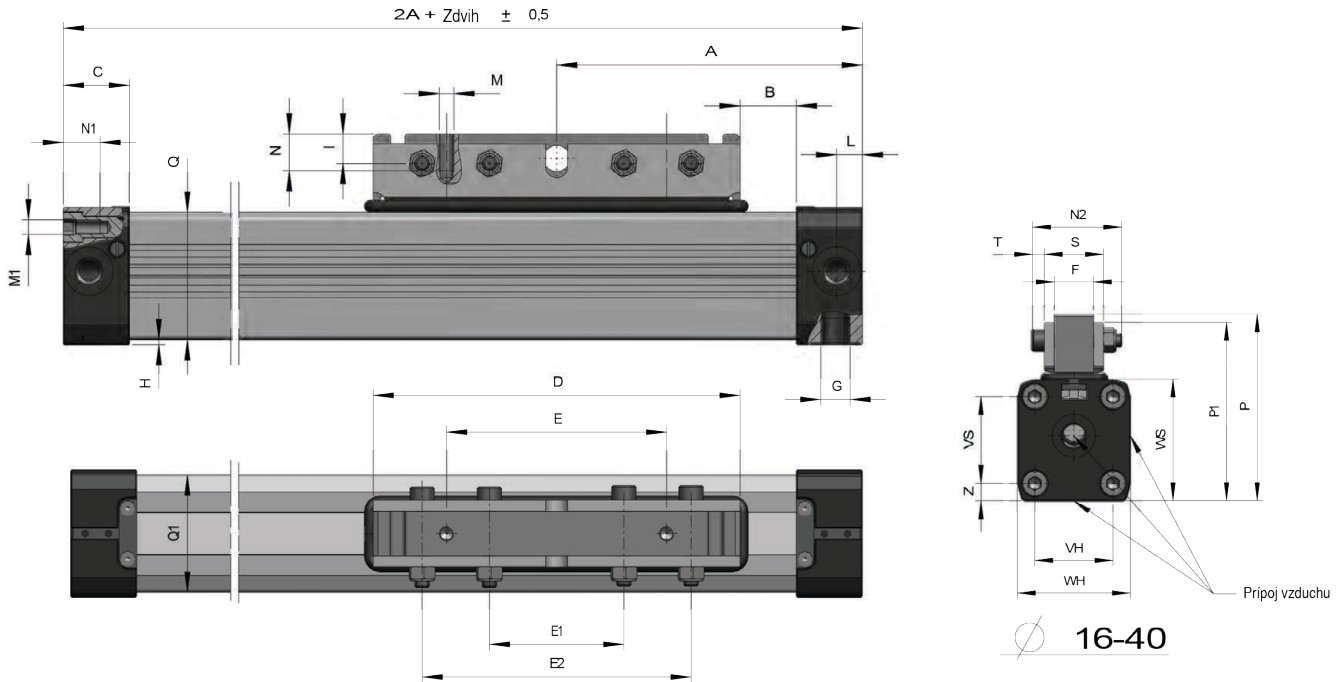

Ø [mm]	A	B	C	D	E	E1	F	G	I	L	M	M1	N1	N2	P-P1
Ø16	65	12	15	76	48	32	10	M5	6	5,5	M4	M3	7	27	43,5 - 42,3
Ø16L	90	37	15	76	48	32	10	M5	6	5,5	M4	M3	7	27	43,5 - 42,3
Ø25	100	17	23	120	80	50	15	G1/8	13	8,5	M5	M5	10	35	66-58
Ø25L	150	67	23	120	80	50	15	G1/8	13	8,5	M5	M5	10	35	66-58
Ø32	125	23	27	150	90	55	18	G1/4	12	10,5	M6	M6	14	41	86-82
Ø32L	200	23	27	300	180	120	18	G1/4	12	10,5	M6	M6	14	41	86-82
Ø40	150	45	30	150	90	55	18	G1/4	12	15	M6	M6	17	41	97-93
Ø40L	250	70	30	300	180	120	18	G1/4	12	15	M6	M6	17	41	97-93

Ø [mm]	P-P1	P1	QxQ1	E2	H	S	T	VH	WH	VS	WS	Z
Ø16	43,5 - 42,3	37,5	24,5x25	64	1	18	4	18	27	18	27	4,5
Ø16L	43,5 - 42,3	37,5	24,5x25	64	1	18	4	18	27	18	27	4,5
Ø25	66-58	53	36x36	100	2	23	5	27	40	27	40	6,5
Ø25L	66-58	53	36x36	100	2	23	5	27	40	27	40	6,5
Ø32	86-82	74	52x51	110	2	27	6	40	52	40	56	8
Ø32L	86-82	74	52x51	240	2	27	6	40	52	40	56	8
Ø40	97-93	85	58,5x59	110	7	28	6	54	72	54	69	9
Ø40L	97-93	85	58,5x59	240	7	28	6	54	72	54	69	9

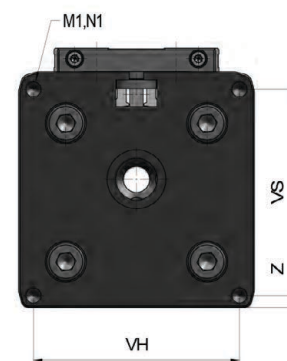
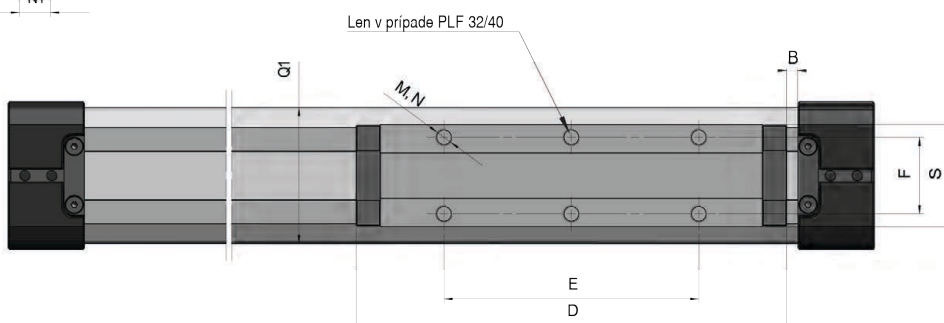
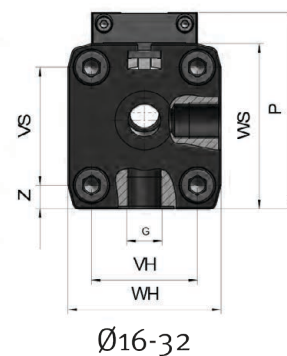
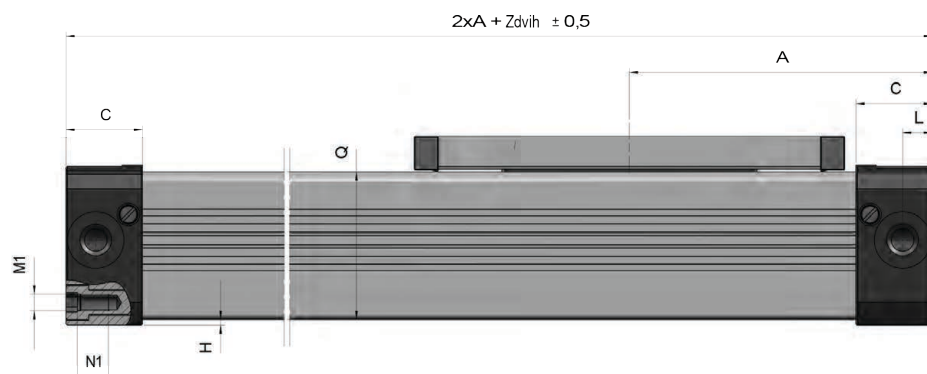

Ø [mm]	A	B	C	D	E	F	G	H	L	M	M1
Ø16	65	15,5	15	69	36	16,5	M5	1	5,5	M4	M3
Ø25	100	21	23	111	65	25	G1/8	2	8,5	M5	M5
Ø32	125	22	27	152	90	27	G1/4	2	10,5	M6	M6
Ø40	150	44	30	152	90	27	G1/4	6,8	15	M6	M6
Ø50	175	42	33	200	110	27	G1/4	0,5	11,7	M6	M6
Ø63	215	47,5	50	235	155	36	G3/8	1,5	25	M8	M8

Ø [mm]	N	N1	P	QxQ1	S	VS	VH	WS	WH	Z
Ø16	7	7	36,5	24,5x25	22	18	18	27	27	4,5
Ø25	10	12	52,5	36x36	33	27	27	40	40	6,5
Ø32	7	14	66,5	52x51	36	40	36	56	52	8
Ø40	10	17	80	58,5x59	36,4	54	54	69	72	9
Ø50	6	18	88	77x78	56	70	70	80	80	4
Ø63	15	18	123	102x102	50	78	78	106	106	14,5

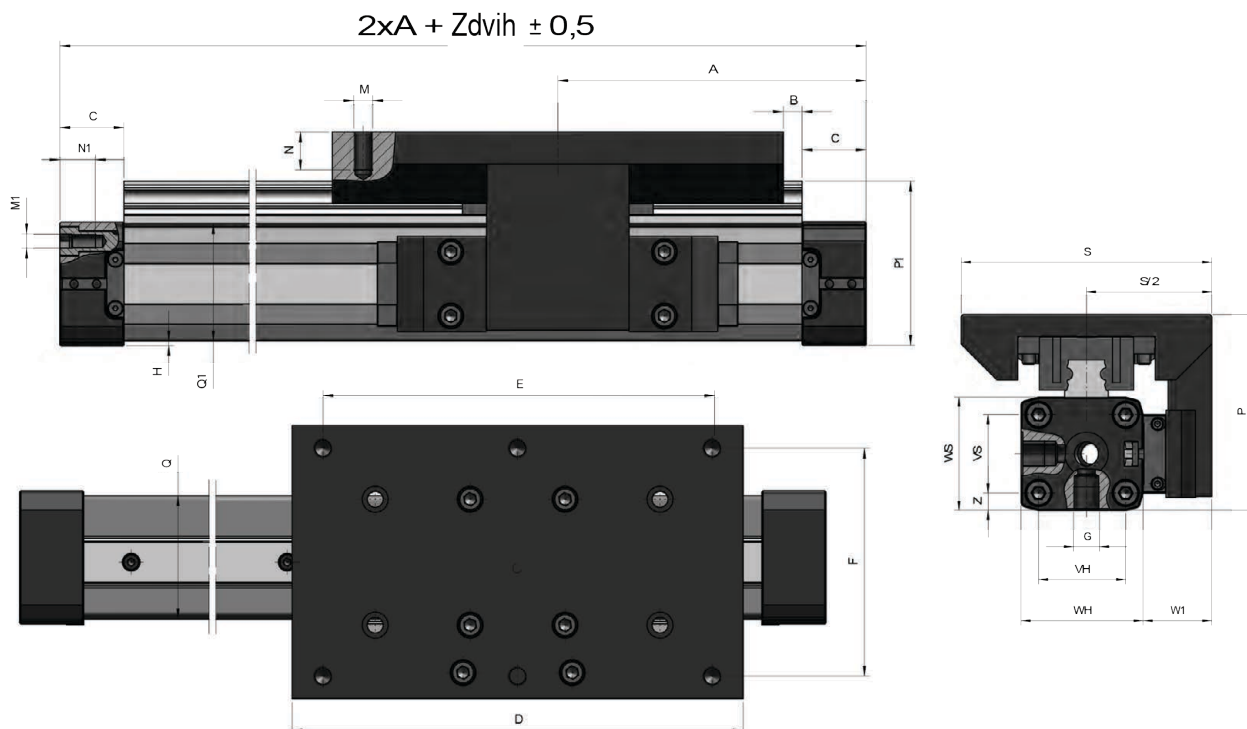

Ø [mm]	A	B	C	D	E	F	G	H	M	N	M1	N1
Ø16	65	5	15	90	70	36	M5	1	M4	10	M3	7
Ø25	100	4,5	23	145	125	64	G1/8	2	M6	12	M5	10
Ø32	125	3	27	190	164	96	G1/4	2	M8	13	M6	14
Ø40	150	25	30	190	164	96	G1/4	7	M8	18	M6	17
Ø50	175	34,5	33	215	180	110	G1/4	1	M8	20	M6	18
Ø63	215	57,5	50	215	180	140	G3/8	2	M8	20	M8	18

Ø [mm]	P	P1	QxQ1	S	S2	VH	VS	WH	WS	W1	Z
Ø16	48,9	34	24,5x25	63	31,5	18	18	27	27	18	4,5
Ø25	73	52,3	36x36	80	40	27	27	40	40	20	6,5
Ø32	90	69,3	48x52	115	57,5	40	36	56	52	30,5	8
Ø40	105	84,3	58x58	115	57,5	54	54	69	72	24,5	9
Ø50	130	102,3	77x78	130	65	70	70	80	80	28,5	5
Ø63	155	128,3	102x102	170	85	78	78	106	106	31,5	14

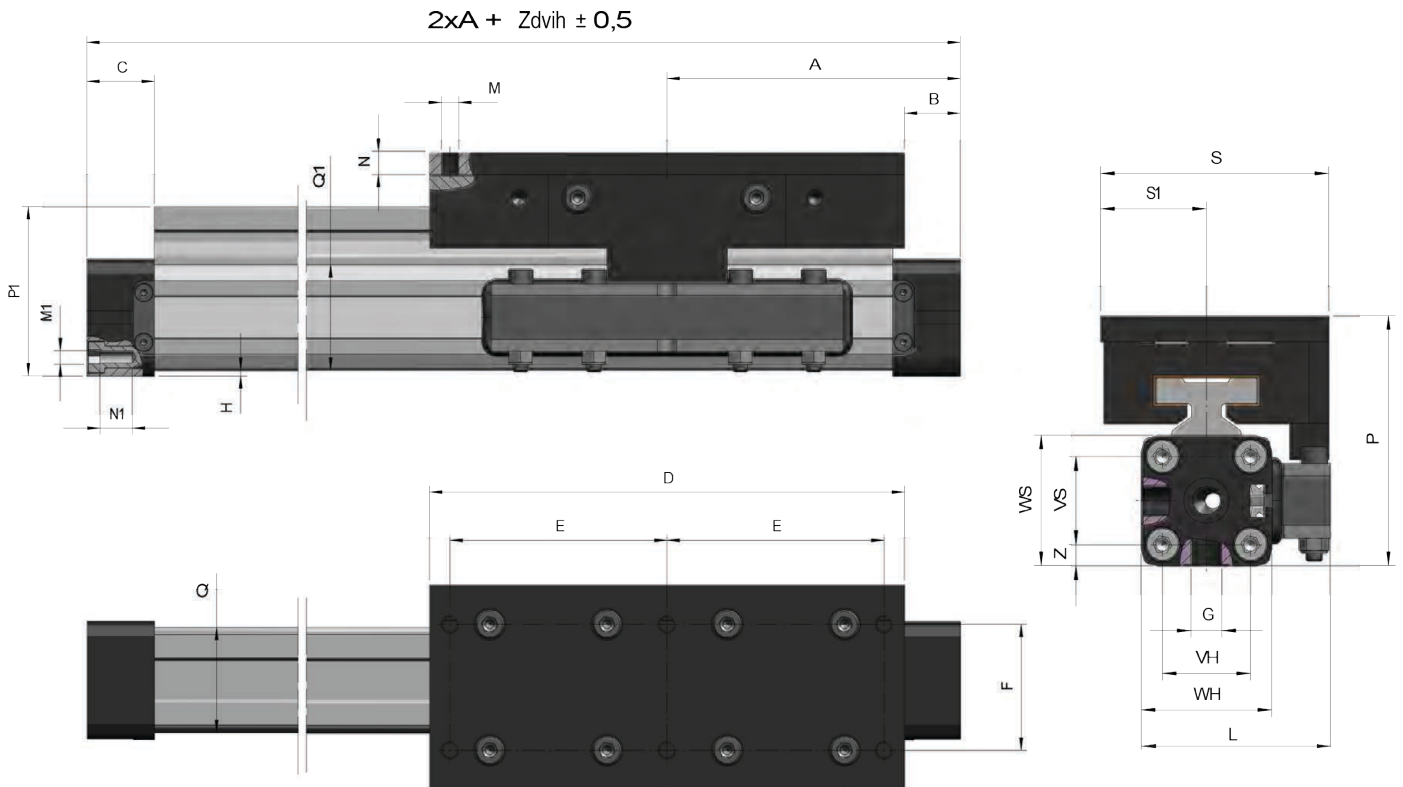
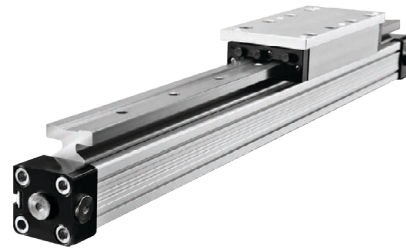

Ø [mm]	A	C	D	E	F	G	H	L	M	N	M1	N1	P	QxQ1	S	S1	VH	VS	WH	WS	Z
Ø 16	65	15	90	20	36	M5	1,5	42,3	M4	10	M3	7	48,5	24,5x25	63	31,5	18	18	27	27	4,5
Ø 25	100	23	162	74	53	G1/8	2	59,5	M6	8	M5	10	76	36x36	70	32,5	27	27	40	40	6,5
Ø 32	125	27	162	74	53	G1/4	2	82	M6	8	M6	14	88,5	52x48	70	32,5	40	36	52	52	8
Ø 40	150	30	162	74	53	G1/4	7	93	M6	8	M6	17	103	58x58	70	32,5	54	54	69	72	9

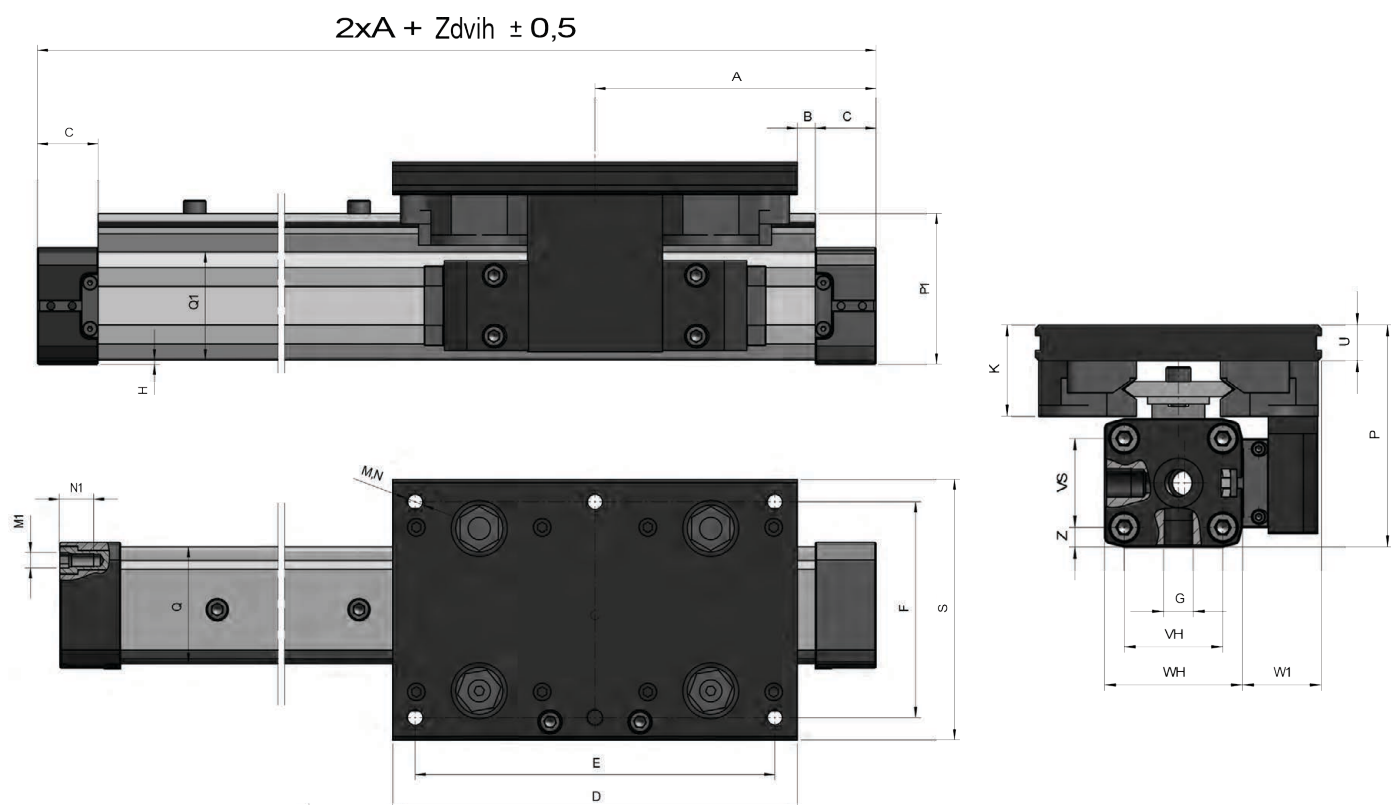
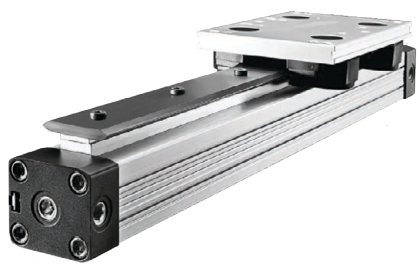

Ø [mm]	A	B	C	D	E	F	G	H	K	M	N	M1
Ø 25	100	9,5	23	135	120	65	G1/8	2	29,5	M6	11	M5
Ø 32	125	8	27	180	160	96	G1/4	2	37	M8	14,5	M6
Ø 40	150	0	30	240	216	115	G1/4	6,75	39	M8	16,5	M6
Ø 50	175	22	33	240	216	115	G1/4	1	39	M8	16,5	M6

Ø [mm]	N1	P	P1	QxQ1	S	U	VH	VS	WH	W1	Z
Ø 25	10	73,5	50,5	36x36	80	11	27	27	40	22	6,5
Ø 32	14	90	64,5	52x48	116	14,5	40	36	56	32	8
Ø 40	17	108,5	84	58,5x59	135	16,5	54	54	69	34,5	9
Ø 50	18	122	97,5	77x78	135	16,5	70	70	80	31	5

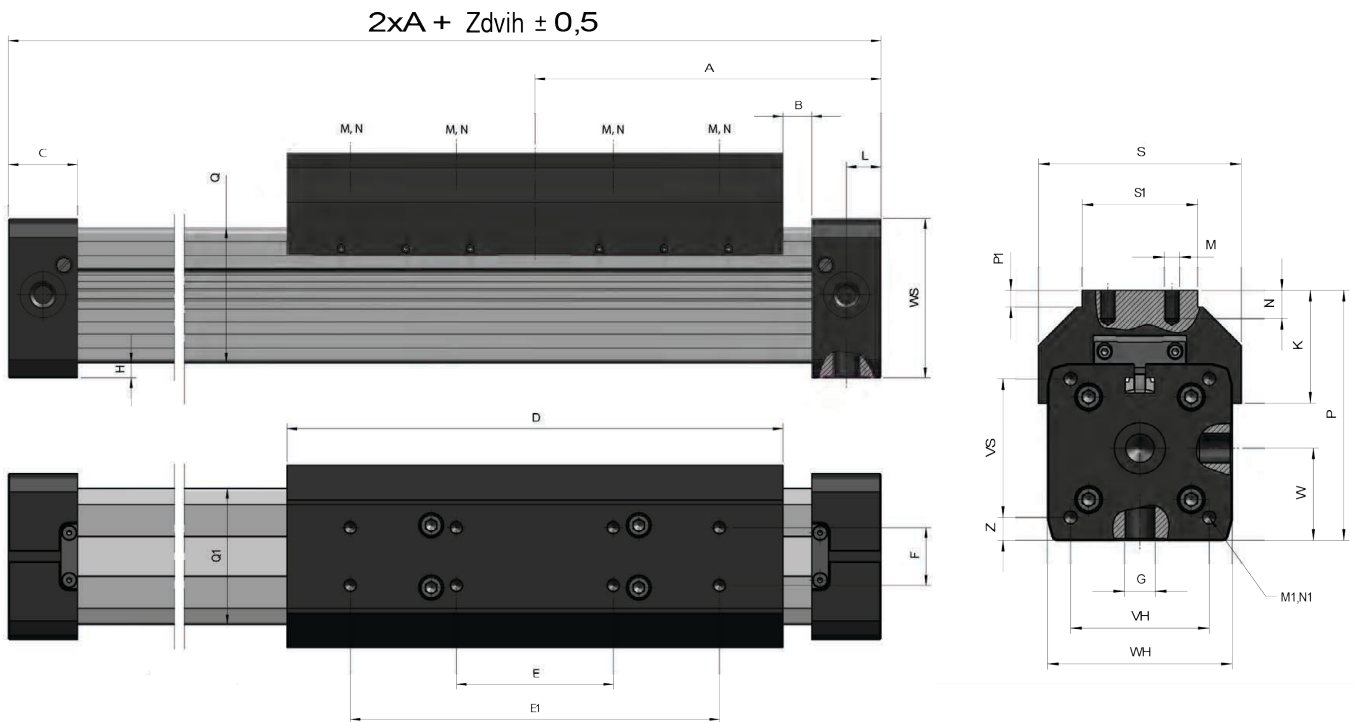

Ø [mm]	A	B	C	D	E	E1	F	G	H	K	L	M	N
Ø 32	125	22	27	152	60	120	25	G1/4	2	42,5	10,5	M5	10
Ø 40	150	12,5	30	215	68	160	25	G1/4	7	44	15	M8	10
Ø 50	175	17,5	33	250	84	190	25	G1/4	0,5	48,5	11,7	M8	10
Ø 63	215	6,5	55	320	120	240	25	G3/8	1,5	56	25	M8	14

Ø [mm]	M1	N1	P	P1	QxQ1	S	S1	VH	VS	W	WH	WS	Z
Ø 32	M6	14	81,5	6,5	52x51	66	40	36	40	30	52	56	8
Ø 40	M6	17	97,5	6,5	58,5x59	79	45	54	54	36	72	69	9
Ø 50	M6	18	110	6,5	77x78	92	50	70	70	43,5	80	80	4
Ø 63	M8	18	137	5	102x102	116	50	78	78	62,5	106	106	14,5

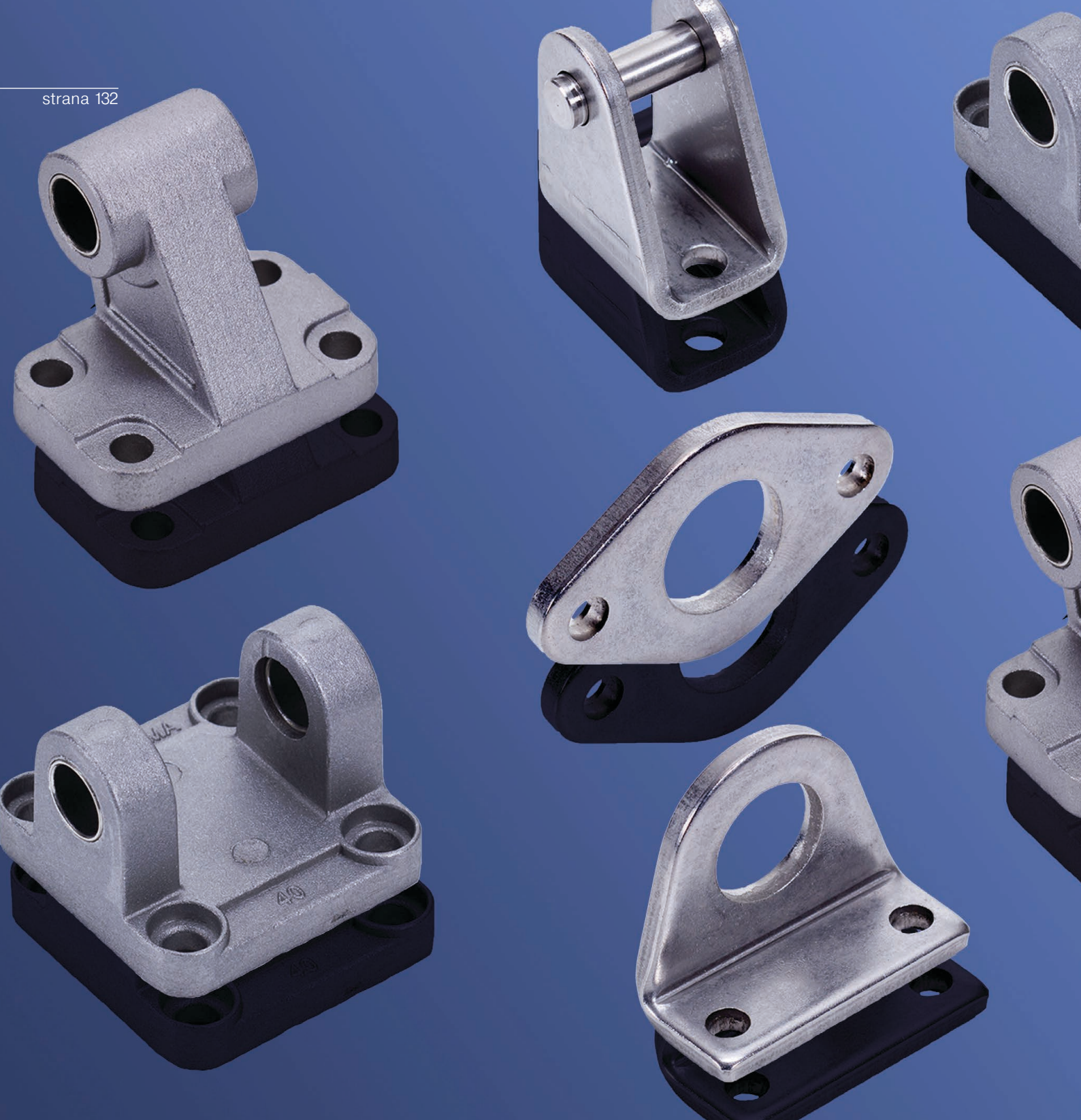

Príslušenstvo k valcom

Príslušenstvo pre montáž na piestnu tyč

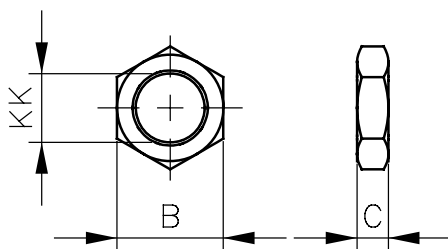

Upevňovacia matica

UA

Typ	Prípoj	KK	B	C
UA-M4	M4	M4	7	3,2
UA-M6	M6	M6	10	5
UA-M8	M8	M8	13	6,5
UA-M10x1,25	M10x1,25	M10x1,25	17	5
UA-M12x1,25	M12x1,25	M12x1,25	19	6
UA-M16x1,5	M16x1,5	M16x1,5	24	8
UA-M20x1,5	M20x1,5	M20x1,5	30	10
UA-M27x2	M27x2	M27x2	41	13

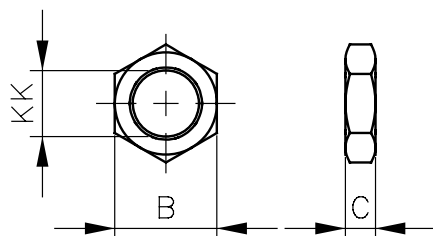

Upevňovacia matica z nehrdzavejúcej ocele

UAX

Typ	Prípoj	KK	B	C
UAX-M6	M6	M6	7	3,2
UAX-M8	M8	M8	10	5
UAX-M10x1,25	M10x1,25	M10x1,25	13	6,5

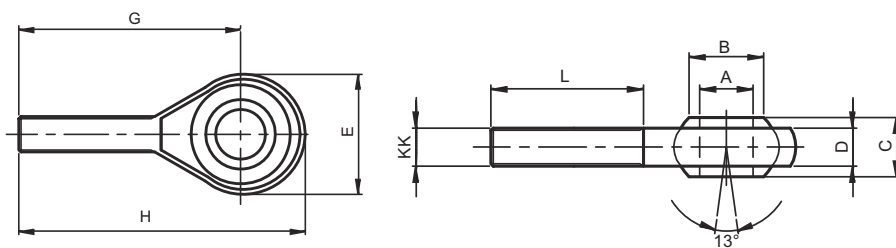

Kĺbová hlavica s vonkajším závitom

UKF

Typ	Prípoj	KK	A	B	C	D	E	G	H	L
UKF-M5	M5	M5	5	7,5	8	7,5	18	33	42	19
UKF-M6	M6	M6	6	8,9	9	7,5	20	36	46	21
UKF-M8	M8	M8	8	10,4	12	9,5	24	42	54	25
UKF-M10	M10	M10	10	12,9	14	11,5	30	48	63	28
UKF-M12	M12	M12	12	15,4	16	12,5	34	54	71	32

Príslušenstvo pre montáž na piestnu tyč

strana 134

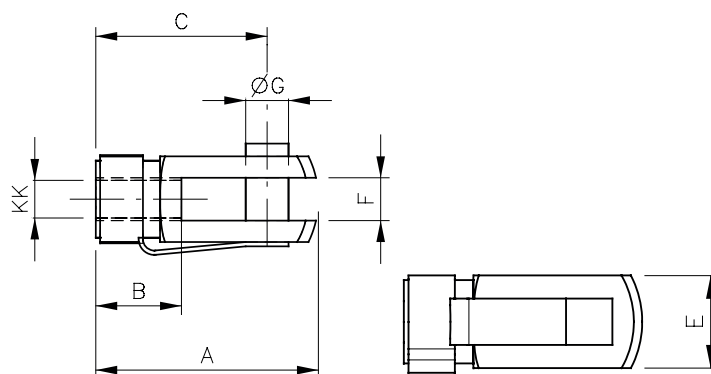

UV

Vidlicová koncovka s upevňovacím čapom

Typ	Prípoj	KK	A	B	C	E	F	G
UV-M4	M4	M4	21	8	16	8	4	4
UV-M6	M6	M6	31	12	24	12	6	6
UV-M8	M8	M8	42	16	32	16	8	8
UV-M10x1,25	M10x1,25	M10x1,25	52	20	40	20	10	10
UV-M12x1,25	M12x1,25	M12x1,25	62	24	48	24	12	12
UV-M16x1,5	M16x1,5	M16x1,5	83	32	64	32	16	16
UV-M20x1,5	M20x1,5	M20x1,5	105	40	80	40	20	20
UV-M27x2	M27x2	M27x2	148	56	110	55	30	30
UV-M36x2	M36x2	M36x2	188	72	144	70	35	35
UV-M42x2	M42x2	M42x2	232	84	168	85	42	42

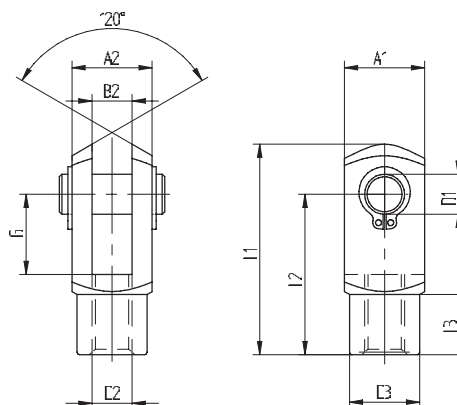

UVX

Vidlicová koncovka s upevňovacím čapom INOX

Typ	A1	A2	B2	G	L1	L2	L3	D2	D3	D1
UVX-M6	12	12	6	12	31	24	9	M6x1	10	6
UVX-M8	16	16	8	16	42	32	12	M8x1,25	14	8
UVX-M10x1,25	20	20	10	20	52	40	15	M10x1,25	18	10
UVX-M12x1,25	24	24	12	24	62	48	18	M12x1,25	20	12
UVX-M16x1,5	32	32	16	32	83	64	24	M16x1,5	26	16
UVX-M20x1,5	40	40	20	40	105	80	30	M20x1,5	34	20
UVX-M27x1,5	55	55	30	54	148	110	38	M27x2	48	30
UVX-M36x2	70	70	35	72	188	144	40	M36x2	60	35

Príslušenstvo pre montáž na piestnu tyč

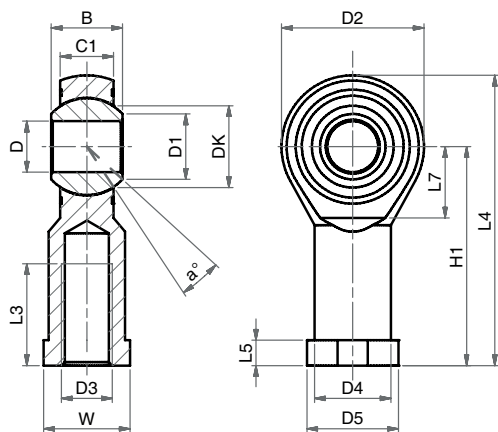

Kľbová hlavica
s vnútorným závitom

UK

Typ	a°	B	C1	D1	D2	D3	D4	D5	DK	ØD	H1	L3	L4	L5	L7	W
UK-M4	13	8	6	7,7	18	M4	9	11	11,11	5	27	10	36	4	10	9
UK-M6	13	9	6,75	8,9	20	M6	10	13	12,7	6	30	12	40	5	11	11
UK-M8	14	12	9	10,4	24	M8	12,5	16	15,87	8	36	16	48	5	13	14
UK-M10x1,25	13	14	10,5	12,9	28	M10x1,25	15	19	19,05	10	43	20	57	6,5	15	17
UK-M12x1,25	13	16	12	15,4	32	M12x1,25	1,75	22	22,22	12	50	22	66	6,5	17	19
UK-M16x1,5	15	21	15	19,3	42	M16x1,5	22	27	28,57	16	64	28	85	8	23	22
UK-M20x1,5	14	25	18	24,3	50	M20x1,5	27,5	34	34,92	20	77	33	102	10	27	30
UK-M27x2	17	37	25	34,8	70	M27x2	40	50	50,8	30	110	51	145	15	36	41
UK-M36x2	16	43	28	37,7	80	M36x2	46	58	57,15	35	125	56	165	17	41	50
UK-M42x2	16	49	33	45,1	91	M42x2	53	65	66,6	40	142	60	187	19	45	55

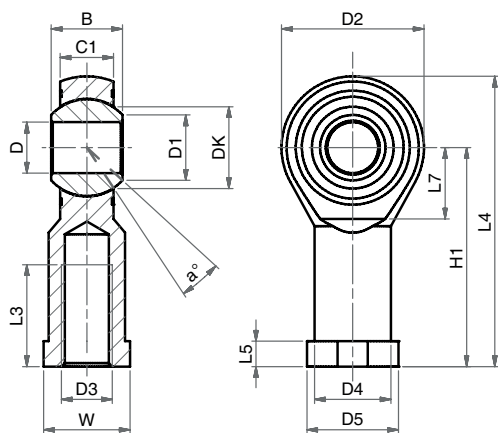

Kľbová hlavica
s vnútorným závitom

UKX

Typ	a°	B	C1	D1	D2	D3	D4	D5	DK	ØD	H1	L3	L4	L5	L7	W
UKX-M4	13	8	6	7,7	18	M4	9	11	11,11	5	27	10	36	4	10	9
UKX-M6	13	9	6,75	8,9	20	M6	10	13	12,7	6	30	12	40	5	11	11
UKX-M8	14	12	9	10,4	24	M8	12,5	16	15,87	8	36	16	48	5	13	14
UKX-M10x1,25	13	14	10,5	12,9	28	M10x1,25	15	19	19,05	10	43	20	57	6,5	15	17
UKX-M12x1,25	13	16	12	15,4	32	M12x1,25	1,75	22	22,22	12	50	22	66	6,5	17	19
UKX-M16x1,5	15	21	15	19,3	42	M16x1,5	22	27	28,57	16	64	28	85	8	23	22
UKX-M20x1,5	14	25	18	24,3	50	M20x1,5	27,5	34	34,92	20	77	33	102	10	27	30
UKX-M27x2	17	37	25	34,8	70	M27x2	40	50	50,8	30	110	51	145	15	36	41
UKX-M36x2	16	43	28	37,7	80	M36x2	46	58	57,15	35	125	56	165	17	41	50
UKX-M42x2	16	49	33	45,1	91	M42x2	53	65	66,6	40	142	60	187	19	45	55

Príslušenstvo pre montáž na piestnu tyč

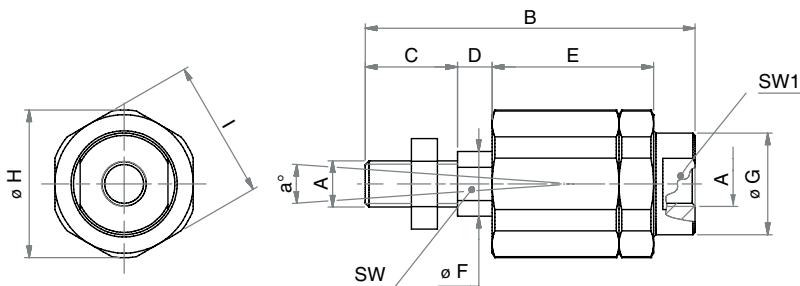
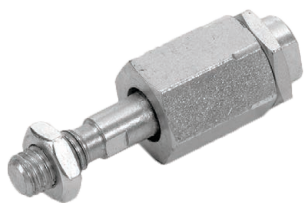

FK

Flexibilná spojka

Typ	Prípoj A	a°	B	C	D	E	ØF	ØG	ØH	I	SW	SW1
FK-M6	M6	6	35	11	2,5	17,5	6	8,5	14,5	13	5	7
FK-M8	M8	8	57	21	5	26	8	12,5	19	17	7	11
FK-M10x1,25	M10x1,25	8	71,5	20	7,5	35	14	22	32	30	12	19
FK-M12x1,25	M12x1,25	8	75,5	24	7,5	35	14	22	32	30	12	19
FK-M16x1,5	M16x1,5	6	104	32	10	53	22	32	45	41	20	27
FK-M20x1,5	M20x1,5	6	119	40	10	53	22	32	45	41	20	27
FK-M27x2	M27x2	8	147	54	10	60	32	57	70	65	24	54

Príslušenstvo ku kruhovým valcom | ISO 6432

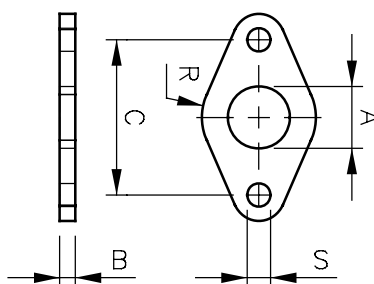

RF

Príruba k valcom série R

Typ	Priemer piestu	A	B	C	R	S
RF 8-10	Ø8-10	12	3	30	9	4,5
RF 12-16	Ø12-16	16	4	40	13	5,5
RF 20-25	Ø20-25	22	5	50	19	6,5

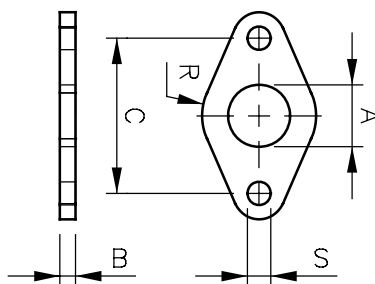

RFX

Príruba z nehrdzavejúcej ocele k valcom série R

Typ	Priemer piestu	A	B	C	R	S
RFX 16	Ø16	16	4	40	13	5,5
RFX 20-25	Ø20-25	22	5	50	19	6,5

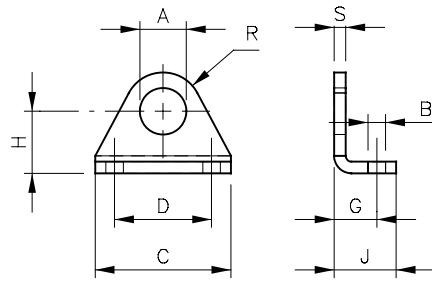

Pätkové upevnenie k valcom série R

RL

Typ	Priemer piestu	A	B	C	D	G	H	J	R	S
RL 8-10	Ø8-10	12	4,5	35	25	11	16	16	10	3
RL 12-16	Ø12-16	16	5,5	42	32	14	20	20	13,5	4
RL 20-25	Ø20-25	22	6,6	54	40	17	25	25	18	5

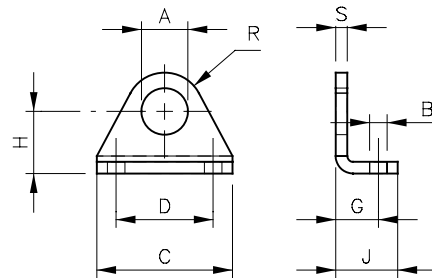

Pätkové upevnenie z nehrdzavejúcej ocele k valcom série R

RLX

Typ	Priemer piestu	A	B	C	D	G	H	J	R	S
RLX 16	Ø16	16	5,5	42	32	14	20	20	13,5	4
RLX 20-25	Ø20-25	22	6,6	54	40	17	25	25	18	5

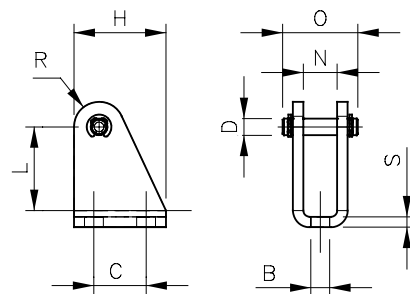

Ložiskové puzdro k valcom série R

RG

Typ	Priemer piestu	B	C	D	H	L	N	O	R	S
RG 8-10	Ø8-10	4,5	12,5	4	20	24	8,1	17	5	2,5
RG 12-16	Ø12-16	5,5	15	6	25	27	12,1	23	7	3
RG 20-25	Ø20-25	6,6	20	8	32	30	16,1	29,5	10	4

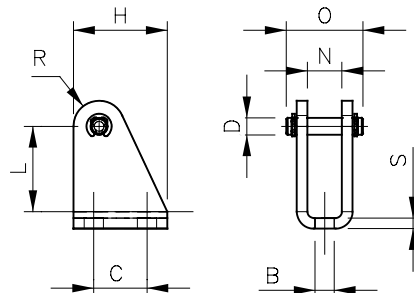

Ložiskové puzdro z nehrdzavejúcej ocele k valcom série R

RGX

Typ	Priemer piestu	B	C	D	H	L	N	O	R	S
RGX 16	Ø16	5,5	15	6	25	27	12,1	23	7	3
RGX 20-25	Ø20-25	6,6	20	8	32	30	16,1	29,5	10	4

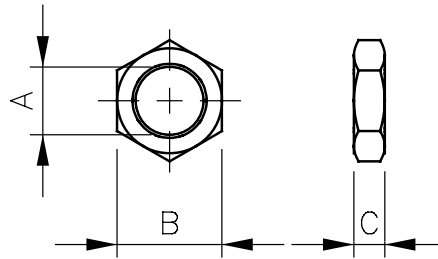

RA

Upevňovacia matica k valcom série R

Typ	Priemer piestu	A	B	C
RA 8-10	Ø8-10	M12x1,25	19	7
RA 12-16	Ø12-16	M16x1,5	22	6
RA 20-25	Ø20-25	M22x1,5	27	8

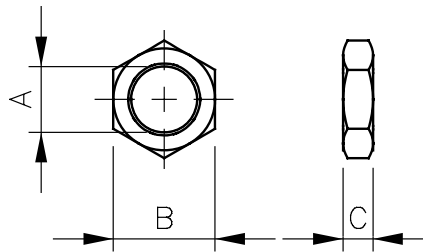

RAX

Upevňovacia matica z nehrdzavejúcej ocele k valcom série R

Typ	Priemer piestu	A	B	C
RAX 16	Ø16	M16x1,5	22	6
RAX 20-25	Ø20-25	M22x1,5	27	8

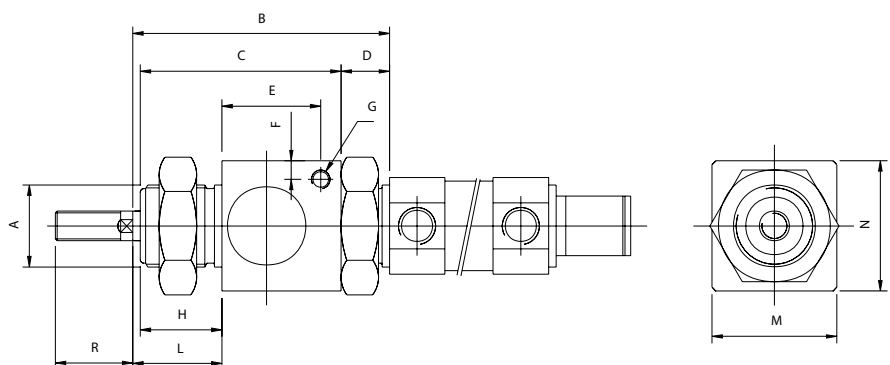

MRL

Brzda k valcom série R

Typ	Priemer piestu	A	B	C	D	E	F	G	H	L	M	N	R
MRL 20	Ø20	M22x1,5	68,5	54	13	27	5	M5	22	23,5	34	35	23
MRL 25	Ø25	M22x1,5	68,5	54	13	27	5	M5	22	24,5	34	35	26

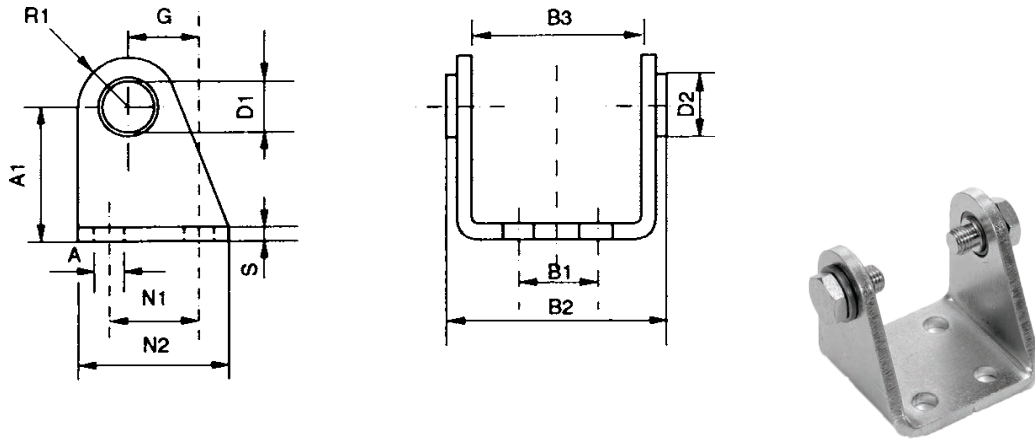

Ložiskové puzdro
k valcom série A

ACC

Typ	Priemer piestu	D1	D2	A	A1	G	M1	N1	N2
ACC 32	Ø32	10	16	7	35	20	M8x1	24	40
ACC 40	Ø40	12	18	9	40	27	M10x1	30	50
ACC 50	Ø50	14	23	9	45	30	M12x1,5	34	54
ACC 63	Ø63	16	24	9	50	34	M14x1,5	35	65

Típuszám	Priemer piestu	R1	S	CH2	B1	B2	B3	V	C1	C2
ACC 32	Ø32	12	4	13	20	50,1	38,1	4	6	18
ACC 40	Ø40	13	5	17	28	60,1	46,1	5	7	21,6
ACC 50	Ø50	14	6	19	36	74,1	57,1	6	9	26,4
ACC 63	Ø63	16	6	19	42	88,1	70,1	6	15	34

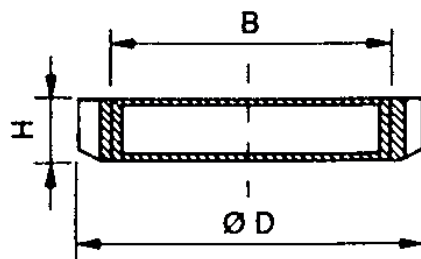

Upevňovacia matica k
valcom série A

AGT

Typ	Priemer piestu	B	D	H
AGT 32	Ø32	M30x1,5	45	7
AGT 40	Ø40	M38x1,5	50	8
AGT 50-63	Ø50-63	M45x1,5	58	9

Príslušenstvo ku kruhovým valcom | Séria A

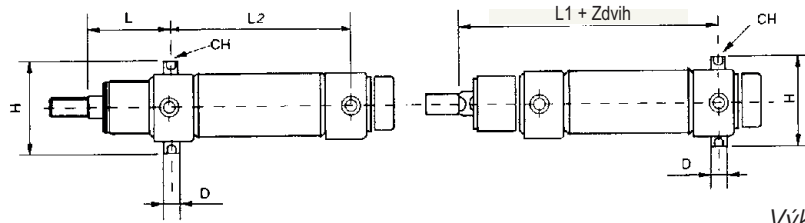

APE

Výkyvný čap
k valcom série A

Typ	Priemer piestu	D	H	L1	L2	L	CH
APE 32	Ø32	10	51	125	78	47	5
APE 40	Ø40	12	61	144	87	57	6
APE 50	Ø50	14	75	158	96	62	6
APE 63	Ø63	16	90	161	98	63	8

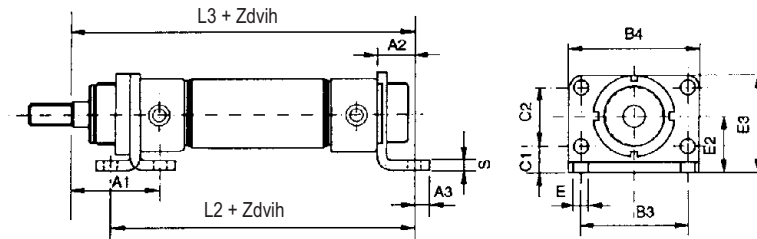

APD

Pätkové upevnenie k
valcom série A

Typ	Priemer piestu	E	E2	E3	C1	C2	L2	L3	B3	B4	S	A1	A2	A3
APD 32	Ø32	7	28	49	14	28	124	148	52	66	4	48	14	7
APD 40	Ø40	9	33	58	18	30	151	176	60	80	5	60	20	10
APD 50	Ø50	9	40	70	20	40	160	190	70	90	6	64	20	10
APD 63	Ø63	9	45	80	20	50	164	194	76	96	6	65	20	10

Príslušenstvo pre normalizované a kompaktné valce | ISO

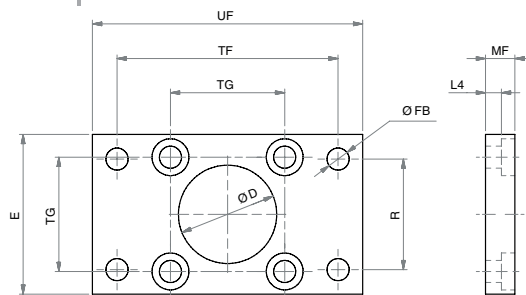

DF

Príruba s rozmermi
upevnenia podľa
ISO-VDMA

Typ	Priemer piestu	E	L4	MF	ØD	ØFB	R	TF	TG	UF
DF 32	Ø32	45	5	10	30	7	32	64	32,5	80
DF 40	Ø40	52	5	10	35	9	36	72	38	90
DF 50	Ø50	65	6,5	12	40	9	45	90	46,5	110
DF 63	Ø63	75	6,5	12	45	9	50	100	56,5	120
DF 80	Ø80	95	9	16	45	12	63	126	72	150
DF 100	Ø100	115	9	16	55	14	75	150	89	170
DF 125	Ø125	140	10,5	20	60	16	90	180	110	205

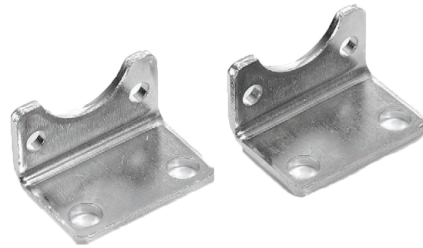
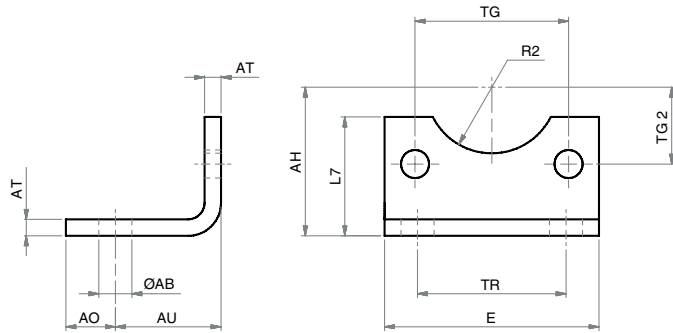

Pätkové upevnenie s rozmermi
upevnenia podľa ISO-VDMA

DL

Typ	Priemer piestu	AH	AO	AT	AU	E	L7	ØAB	R2	TG2	TG	TR
DL 32	Ø32	32	11	4	24	45	30	7	15	16,25	32,5	32
DL 40	Ø40	36	8	4	28	52	30	10	17,5	19	38	36
DL 50	Ø50	45	15	5	32	65	36	10	20	23,25	46,5	45
DL 63	Ø63	50	13	5	32	75	35	10	22,5	28,25	56,5	50
DL 80	Ø80	63	14	6	41	95	47	12	22,5	36	72	63
DL 100	Ø100	71	16	6	41	115	53	14,5	27,5	44,5	89	75
DL 125	Ø125	90	25	8	45	140	70	16,5	30	55	110	90
DL 160	Ø160	115	15	10	60	180	100	18,5	32,5	70	140	115
DL 200	Ø200	135	30	12	70	220	109	24	37,5	87,5	175	135

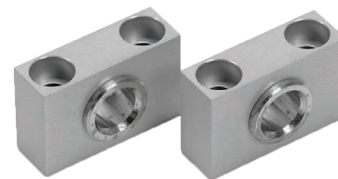
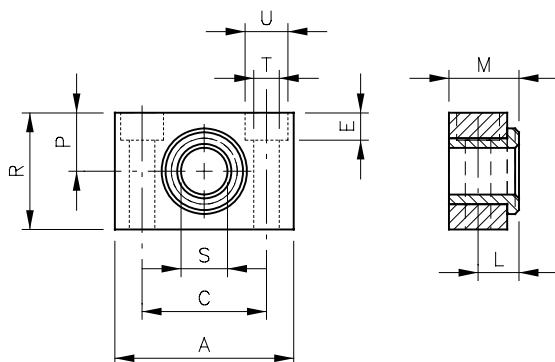

Konzola na upevnenie

DSL

Typ	Priemer piestu	A	C	E	L	M	P	R	S	T	U
DSL 32	Ø32	46	32	7	10,5	18	15	30	12	6,6	11
DSL 40-50	Ø40-50	55	36	9	12	21	18	36	16	9	15
DSL 63-80	Ø63-80	65	42	11	13	23	20	40	20	11	18
DSL 100-125	Ø100-125	75	50	13	16	28,5	25	50	25	14	20

Príslušenstvo pre normalizované a kompaktné valce | ISO

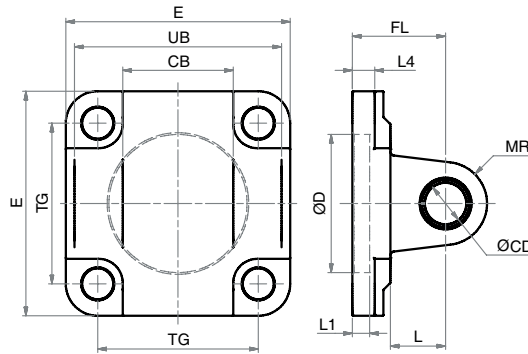

Vidlicová príruha s rozmermi upevnenia podľa ISO-VDMA

DG

Typ	Priemer piestu	CB	E	FL	L1	L4	L	MR	ØCD	ØD	TG	UB
DG 32	Ø32	26	45	22	5	5,5	13	10	10	30	32,5	45
DG 40	Ø40	28	52	25	5	5,5	16	12	12	35	38	52
DG 50	Ø50	32	65	27	5	6,5	16	12	12	40	46,5	60
DG 63	Ø63	40	75	32	5	6,5	21	16	16	45	56,5	70
DG 80	Ø80	50	93	36	5	10	22	16	16	45	72	90
DG 100	Ø100	60	110	41	5	10	27	20	20	55	89	110
DG 125	Ø125	70	134	50	7	10	30	25	25	60	110	130
DG 160	Ø160	90	180	55	7	10	35	25	30	65	140	170
DG 200	Ø200	90	220	60	7	10	35	25	30	75	175	170
DG 250	Ø250	110	270	70	-	17	45	40	40	90	220	200
DG 320	Ø320	120	350	80	-	22	50	45	45	110	270	220

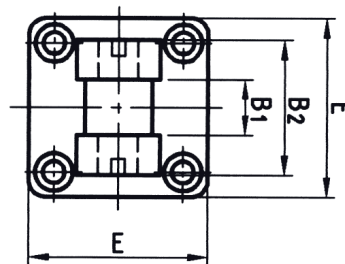
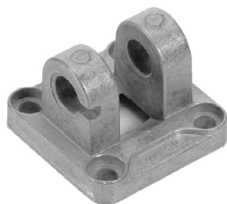

DGS

Vidlicová príruha ku klbovej prírubě

Typ	Priemer piestu	B1	B2	CN	E	FL	R1	R2	XD
DGS 32	Ø32	14	34	10	45	22	10	17	142
DGS 40	Ø40	16	40	12	52	25	12	20	160
DGS 50	Ø50	21	45	16	65	27	14	22	170
DGS 63	Ø63	21	51	16	75	32	18	25	190
DGS 80	Ø80	25	65	20	95	36	20	30	210
DGS 100	Ø100	25	75	20	115	41	22	32	230
DGS 125	Ø125	37	97	30	140	50	25	42	275

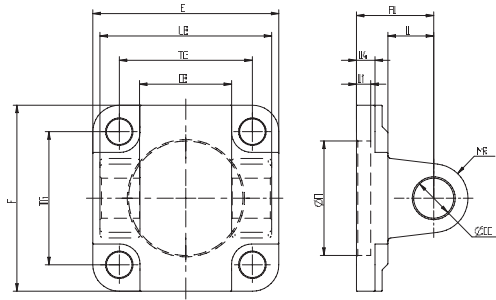

Vidlicová príruha
INOX

DGX

Typ	Priemer piestu	CB	E	FL	L1	L4	L	MR	CD	D	TG	UB
DGX 32	Ø32	26	45	22	5	5,5	13	10	10	30	32,5	45
DGX 40	Ø40	28	52	25	5	5,5	16	12	12	35	38	52
DGX 50	Ø50	32	65	27	5	6,5	16	12	12	40	46,5	60
DGX 63	Ø63	40	75	32	5	6,5	21	16	16	45	56,5	70
DGX 80	Ø80	50	93	36	5	10	22	16	16	45	72	90
DGX 100	Ø100	60	110	41	5	10	27	20	20	55	89	110
DGX 125	Ø125	70	134	50	7	10	30	25	25	60	110	130

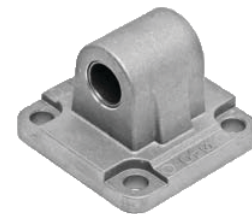
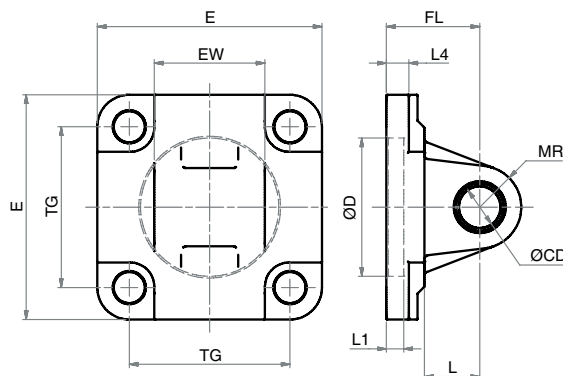

Príruha s okom s
rozmermi upevnenia
podľa ISO-VDMA

DH

Typ	Priemer piestu	EW	E	FL	L1	L4	L	MR	ØCD	ØD	TG
DH 32	Ø32	26	45	22	5	5,5	13	10	10	30	32,5
DH 40	Ø40	28	52	25	5	5,5	16	12	12	35	38
DH 50	Ø50	32	65	27	5	6,5	16	12	12	40	46,5
DH 63	Ø63	40	75	32	5	6,5	21	16	16	45	56,5
DH 80	Ø80	50	93	36	5	10	22	16	16	45	72
DH 100	Ø100	60	110	41	5	10	27	20	20	55	89
DH 125	Ø125	70	134	50	7	10	30	25	25	60	110
DH 160	Ø160	90	180	55	7	10	35	25	30	65	140
DH 200	Ø200	90	220	60	10	11	35	25	30	75	175
DH 250	Ø250	110	270	70	11	17	45	40	40	90	220
DH 320	Ø320	120	350	80	11	22	50	45	45	110	270

Príslušenstvo pre normalizované a kompaktné valce | ISO

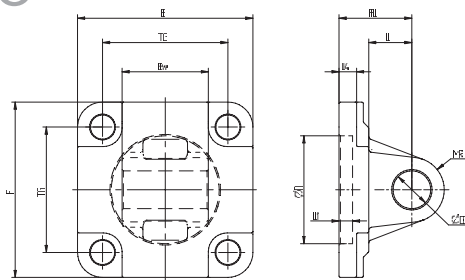

Vidlicová príruha INOX

DHX

Typ	Priemer piestu	E	EW	TG	FL	L1	L	L4	D	CD	MR
DHX 32	Ø32	45	26	32,5	22	5	13	5,5	30	10	10
DHX 40	Ø40	52	28	38	25	5	16	5,5	35	12	12
DHX 50	Ø50	65	32	46,5	27	5	16	6,5	40	12	12
DHX 63	Ø63	75	40	56,5	32	5	21	6,5	45	16	16
DHX 80	Ø80	93	50	72	36	5	22	10	45	16	16
DHX 100	Ø100	110	60	89	41	5	27	10	55	20	20
DHX 125	Ø125	134	70	110	50	7	30	10	60	25	25

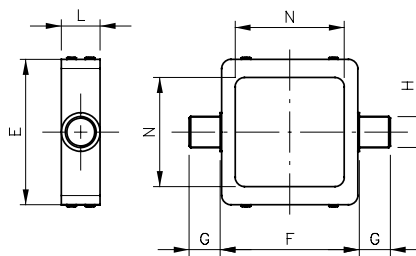
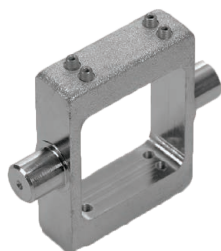

Výkyvné upevnenie pre valce s plochým profilom

DP

Typ	Priemer piestu	E	F	G	H	L	N
DP 32	Ø32	71	50	12	12	18	45
DP 40	Ø40	79	63	16	16	20	51
DP 50	Ø50	91	75	16	16	20	60,8
DP 63	Ø63	96	90	20	20	26	70,5
DP 80	Ø80	132	110	20	20	26	87,5
DP 100	Ø100	147	132	25	25	30	107
DP 125	Ø125	155	155	25	25	32	133

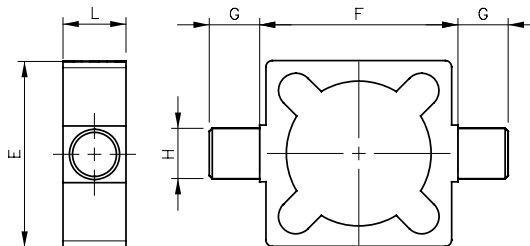

Výkyvné upevnenie

DS

Typ	Priemer piestu	E	F	G	H	L
DS 32	Ø32	49	50	12	12	18
DS 40	Ø40	59	63	16	16	20
DS 50	Ø50	71	75	16	16	20
DS 63	Ø63	75	90	20	20	26
DS 80	Ø80	105	110	20	20	26
DS 100	Ø100	129	132	25	25	32
DS 125	Ø125	154	160	25	25	33

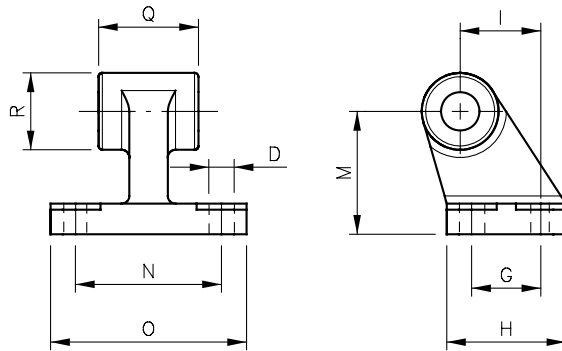

Príruba s okom (90°) s rozmermi upevnenia podľa ISO-VDMA

DW

Typ	Priemer piestu	BR	BT	ØCK	EA	EM	GL	LB	ØHB	PH	RA	TE	UL	UR
DW 32	Ø32	10	8	10	10	26	21	6,4	6,6	32	18	38	51	31
DW 40	Ø40	11	10	12	15	28	24	8,4	6,6	36	22	41	54	35
DW 50	Ø50	13	12	12	16	32	33	10,4	9	45	30	50	65	45
DW 63	Ø63	15	14	16	16	40	37	12,4	9	50	35	52	67	50
DW 80	Ø80	15	14	16	20	50	47	11,5	11	63	40	66	86	60
DW 100	Ø100	19	17	20	20	60	55	14,5	11	71	50	76	96	70
DW 125	Ø125	22,5	20	25	30	70	70	16,8	14	90	60	94	124	90
DW 160	Ø160	31,5	25	30	36	90	97	21	14	115	88	118	156	126
DW 200	Ø200	31,5	30	30	40	90	105	26	18	135	90	122	162	130

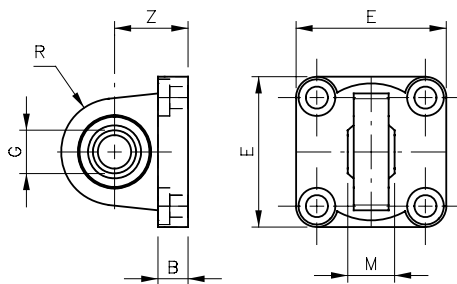

Kĺbová príruba s rozmermi upevnenia podľa ISO-VDMA

DKL

Typ	Priemer piestu	B	E	G	M	R	Z
DKL 32	Ø32	9	45	10	14	16	22
DKL 40	Ø40	9	52	12	16	19	25
DKL 50	Ø50	11	65	16	21	21	27
DKL 63	Ø63	11	75	16	21	24	32
DKL 80	Ø80	14	95	20	25	28	36
DKL 100	Ø100	14	115	20	25	30	41
DKL 125	Ø125	20	140	30	37	40	50

Príslušenstvo pre normalizované a kompaktné valce | ISO

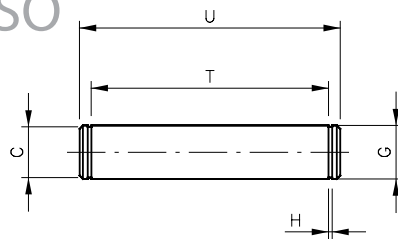

Upínací kolík s rozmermi upevnenia podľa ISO-VDMA

DC

Typ	Priemer piestu	C	G	H	T	U
DC 32	Ø32	9,6	10	1,1	46	53
DC 40	Ø40	11,5	12	1,1	53	60
DC 50	Ø50	11,5	12	1,1	61	68
DC 63	Ø63	15,2	16	1,1	71	78
DC 80	Ø80	15,2	16	1,1	91	98
DC 100	Ø100	19	20	1,3	111	118
DC 125	Ø125	23,9	25	1,3	132	139
DC 160-200	Ø160-200	30	28,6	1,6	172	180
DC 250	Ø250	40	37,5	1,85	202	211
DC 320	Ø320	45	42,5	1,85	222	234

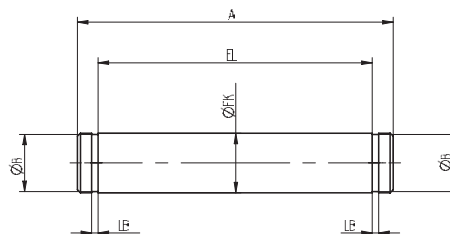

Upínací kolík INOX

DCX

Typ	Priemer piestu	A	B	EL	EK	LB
DCX 32	Ø32	53	9,6	46	10	1,1
DCX 40	Ø40	60	11,5	53	12	1,1
DCX 50	Ø50	68	11,5	61	12	1,1
DCX 63	Ø63	78	15,2	71	16	1,1
DCX 80	Ø80	98	15,2	91	16	1,1
DCX 100	Ø100	118	19	111	20	1,3
DCX 125	Ø125	139	23,9	132	25	1,3



Upínací kolík k DGS príruže s rozmermi upevnenia podľa ISO-VDMA

DCS

Typ	Priemer piestu
DCS 32	Ø32
DCS 40	Ø40
DCS 50	Ø50
DCS 63	Ø63
DCS 80	Ø80
DCS 100	Ø100
DCS 125	Ø125



Upevnenie slúžiace pre montáž ventilu na valec

ZHA

Typ	Priemer piestu
ZHA-032 SET	Ø32
ZHA-040 SET	Ø40
ZHA-050 SET	Ø50
ZHA-063 SET	Ø63
ZHA-080 SET	Ø80
ZHA-100 SET	Ø100
ZHA-125 SET	Ø125

Príslušenstvo pre normalizované a kompaktné valce | ISO

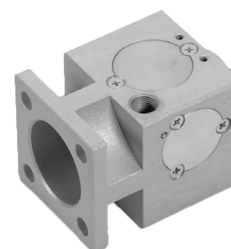
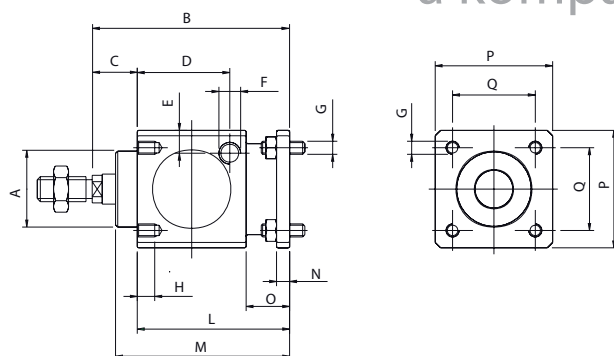

Brzda k valcom ISO 15552

VRL

Typ	Priemer piestu	A	B	C	D	E	F	G	H	L	M	N	O	P	Q
VRL 32	Ø32	30	86	26	33,25	9	G1/8	M6	8	60	67,5	6	20	47	32,5
VRL 40	Ø40	34,5	100	30	42,5	9	G1/8	M6	8	70	80	6	20	54	38
VRL 50	Ø50	40	127	37	58	12,5	G1/8	M8	12	90	100	8	24	65	46,5
VRL 63	Ø63	45	127	37	59	17,5	G1/8	M8	12	90	100	8	24	75	56,5
VRL 80	Ø80	45	156	46	69	17,5	G1/4	M10	16	110	120	12	32	95	72
VRL 100	Ø100	55	161	51	69	20	G1/4	M10	16	110	120	12	32	114	89
VRL 125	Ø125	60	205	65	84,5	19	G1/4	M12	20	140	156	20	45	138	110

Príslušenstvo pre kompaktné valce | UNITOP

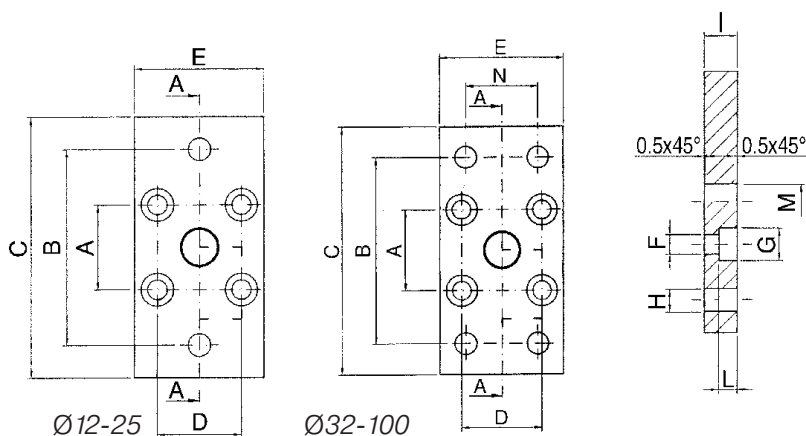

Príruba s rozmermi upevnenia UNITOP

QFL

Typ	Priemer piestu	A	B	C	D	E	F	G	H	I	L	M	N
QFL 12-16	Ø12-16	18	43	55	18	29	4,5	9	5,5	10	5,4	10	-
QFL 20	Ø20	22	55	70	22	36	5,5	10	6,6	10	5,4	12	-
QFL 25	Ø25	26	60	76	26	40	5,5	10	6,6	10	5,4	12	-
QFL 32	Ø32	32	65	80	32	50	6,6	11	7	10	6,4	14	32
QFL 40	Ø40	42	82	102	42	60	6,6	11	9	10	6,4	14	36
QFL 50	Ø50	50	90	110	50	68	9	15	9	12	8,6	18	45
QFL 63	Ø63	62	110	130	62	87	11	15	9	15	10,6	18	50
QFL 80	Ø80	82	135	160	82	107	11	18	12	15	10,6	23	63
QFL 100	Ø100	103	163	190	103	128	11	18	14	15	10,6	28	75

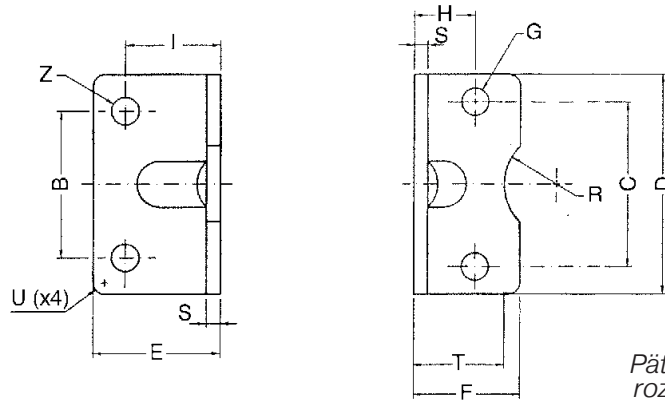

Pätkové upevnenie s rozmermi upevnenia UNITOP

QCP

Typ	Priemer piestu	C	B	D	E	F	G	H	I	S	T	R	U	Z
QCP 12-16	Ø12-16	18	18	30	17,5	17,5	4,4	13	13	3	15	9	2	5,5
QCP 20	Ø20	22	22	36	22	22	5,4	16	16	4	17	10	2	6,6
QCP 25	Ø25	26	26	40	22	23	5,4	17	16	4	19	11	2	6,6
QCP 32	Ø32	32	32	50	26	24	6,6	16	18	5	20	12	2	6,6
QCP 40	Ø40	42	42	60	28	29,5	6,6	21,5	20	5	-	-	5	9
QCP 50	Ø50	50	50	68	32	30	9	22	24	6	-	-	5	9
QCP 63	Ø63	62	62	84	39	39	9	28,5	27	6	-	-	5	11
QCP 80	Ø80	82	82	102	36,5	36,5	11	24,5	30	8	-	-	5	11
QCP 100	Ø100	103	103	123	38,5	38,5	11	26,5	33	8	-	-	5	13,5

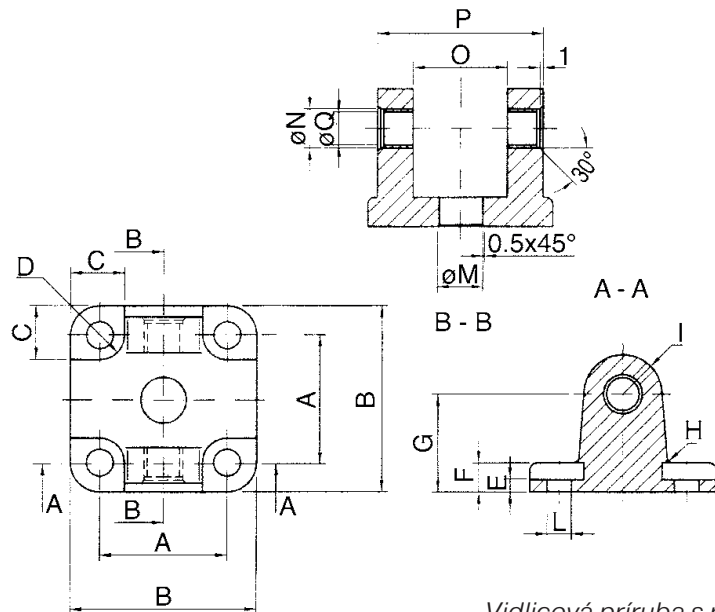

Vidlicová príruha s rozmermi upevnenia UNITOP

QCF

Typ	Priemer piestu	A	B	C	D	E	F	G	H	I	L	M	N	O	P	Q
QCF 32	Ø32	32	48	13,5	5,5	5,5	9	22	2,5	10	6,6	14	12	26	45	10
QCF 40	Ø40	42	58	13,5	5,5	5,5	9	25	2,5	12,5	6,6	14	14	28	52	12
QCF 50	Ø50	50	66	15,5	6,5	6,5	11	27	2,5	12,5	9	18	14	32	60	12
QCF 63	Ø63	62	83	18	6,5	6,5	11	32	4	15	11	18	18	40	70	16
QCF 80	Ø80	82	102	19	10	10	13	36	4	15	11	23	18	50	90	16
QCF 100	Ø100	103	123	19	10	10	15	41	4	20	11	28	23	60	110	20

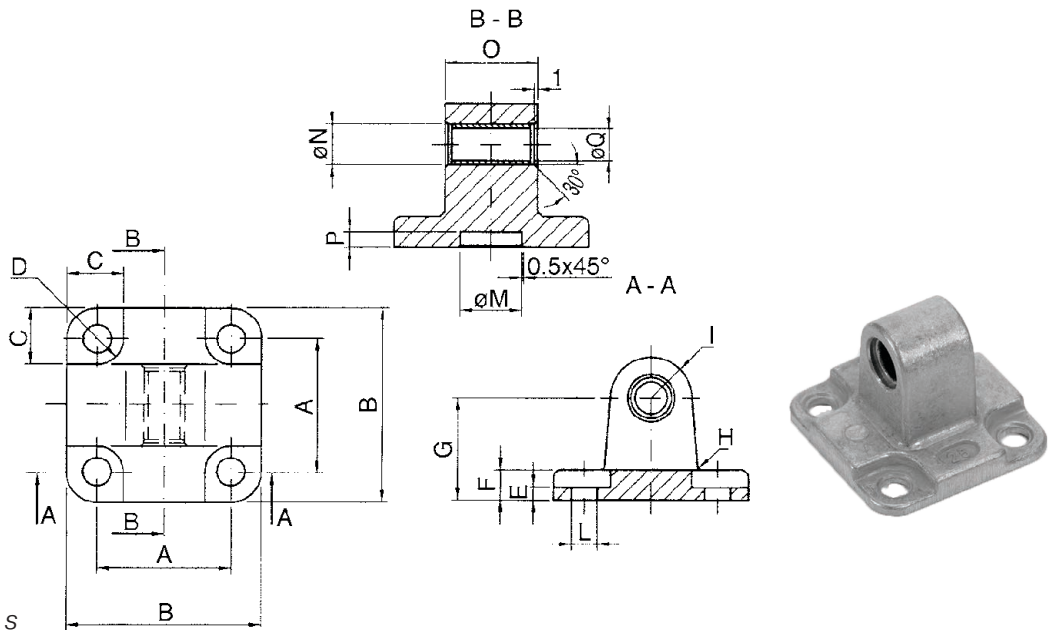

Príruba s okom s
rozmermi upevnenia
UNITOP

QCM

Typ	Priemer piestu	A	B	C	D	E	F	G	H	I	L	M	N	O	P	Q
QCM 12-16	Ø12-16	18	27	10	4,5	2,6	6	16	2	6	4,5	10	8	12	3	6
QCM 20	Ø20	22	34	11	5	2,6	6	20	2	8	5,5	12	10	16	3	8
QCM 25	Ø25	26	38	11	5	2,6	6	20	2	8	5,5	12	10	16	3	8

Snímače polohy

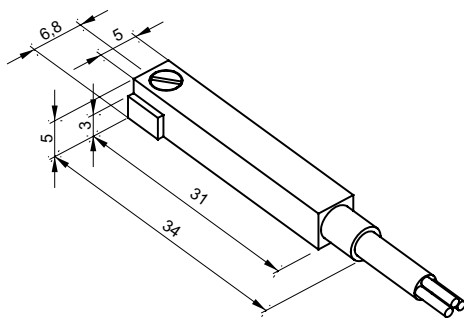

Snímač | REED relé / jazýčkové relé

SKR

Typ	Napätie	Max. prúd	Dĺžka kábla	Teplota okolia
SKR-130	5...130 V AC/DC	200 mA	2 m	-5°C...+70°C
SKR-230	5...230 V AC	200 mA	2 m	-5°C...+70°C

Snímač | PNP snímač

SKH

Typ	Napätie	Max. prúd	Dĺžka kábla	Teplota okolia
SKH-30	10...30 V DC	200 mA	2 m	-5°C...+70°C
SKH-30-M8	10...30 V DC	200 mA	0,3 m (M8x1)	-5°C...+70°C

Snímače polohy

strana 150

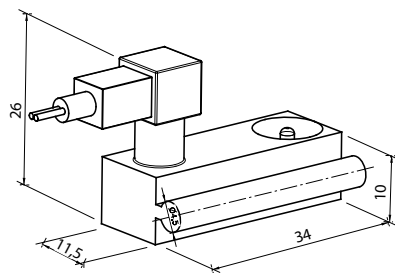

SM

Snímač | REED relé / jazýčkové relé

Typ	Napätie	Max. prúd	Dĺžka kábla	Teplota okolia
SM	3...230 V AC/DC	500 mA	2,5 m	-20°C...+85°C

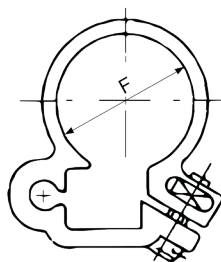

RX

Upevňovacia jednotka | pre SKR/SKH snímač | k valcom série R

Typ	Priemer piestu	F
RX 8	Ø8	9,3
RX 10	Ø10	11,3
RX 12	Ø12	13,3
RX 16	Ø16	17,3
RX 20	Ø20	21,3
RX 25	Ø25	26,3

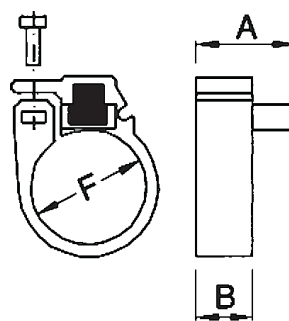

RXP

Upevňovacia jednotka | pre SKR/SKH snímač | k valcom série R

Typ	Priemer piestu	F	A	B
RXP 8	Ø8	9,4	14	8
RXP 10	Ø10	11,3	14	8
RXP 12	Ø12	13,3	14	8
RXP 16	Ø16	17,3	14	8
RXP 20	Ø20	21,3	14	8
RXP 25	Ø25	26,3	14	8



Upevňovacia jednotka
pre SM snímač
k valcom série D s profilom L

DX

Typ	Priemer piestu
DX 32-40	Ø32-40
DX 50-63	Ø50-63
DX 80	Ø80
DX 100-125	Ø100-125



Upevňovacia jednotka
pre SKR/SKH snímač
k valcom série D s profilom L

DXS

Typ	Priemer piestu
DXS 32-40	Ø32-40
DXS 50-63	Ø50-63
DXS 80	Ø80
DXS 100-125	Ø100-125

Súpravy na opravu piestnicových valcov

Súprava na opravu
valcov série Q
UNITOP

QIR

Typ	Priemer piestu
QIR-12	Ø12
QIR-16	Ø16
QIR-20	Ø20
QIR-25	Ø25
QIR-32	Ø32
QIR-40	Ø40
QIR-50	Ø50
QIR-63	Ø63
QIR-80	Ø80
QIR-100	Ø100



Súprava na opravu
valcov série D
ISO 15552

DIR

Typ	Priemer piestu
DIR-32	Ø32
DIR-40	Ø40
DIR-50	Ø50
DIR-63	Ø63
DIR-80	Ø80
DIR-100	Ø100
DIR-125	Ø125

Súprava na opravu
valcov série H
ISO 15552

HIR

Typ	Priemer piestu
HIR-32	Ø32
HIR-40	Ø40
HIR-50	Ø50
HIR-63	Ø63
HIR-80	Ø80
HIR-100	Ø100
HIR-125	Ø125

Súprava na opravu
valcov série V
ISO 21287

VIR

Typ	Priemer piestu
VIR-32	Ø32
VIR-40	Ø40
VIR-50	Ø50
VIR-63	Ø63
VIR-80	Ø80
VIR-100	Ø100

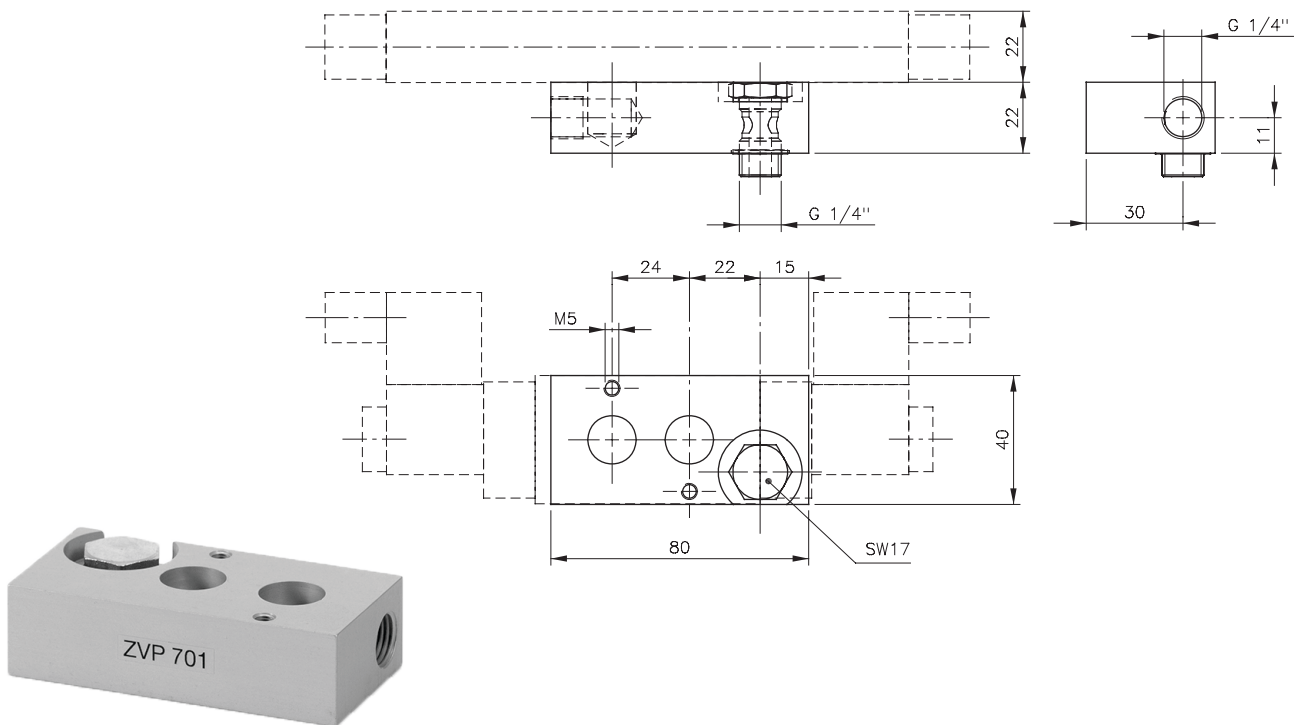

ZVP

*Upevnenie k NAMUR ventilom
pre montáž na valec*

Typ	Prípoj A	Prípoj B	Menovitý priemer	Montážna veľkosť
ZVP 701	G1/4" dutá skrutka	G1/4"	DN 7	NAMUR [G1/4"]
ZVP 101	G3/8" dutá skrutka	G3/8"	DN 10	NAMUR [G1/4"]
ZVP 121	G1/2" dutá skrutka	G1/2"	DN 12	NAMUR [G1/2"]
ZVP 121-701	G1/2" dutá skrutka	G1/4"	DN 7	NAMUR [G1/4"]

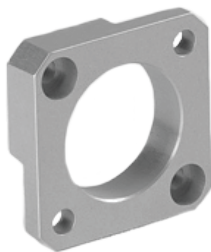

TZA

*Viacpolohová
konštrukčná súprava*

Typ
TZA-032 SET
TZA-040 SET
TZA-050 SET
TZA-063 SET
TZA-080 SET
TZA-100 SET

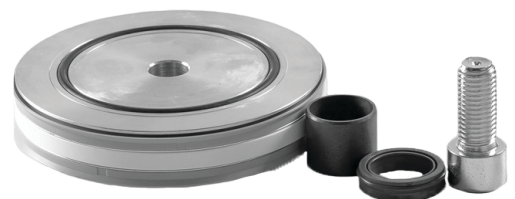

VTS LAZ

*Súprava na opravu
prítlačných a LAZ valcov*

Typ
VTS LAZ 80
VTS LAZ 100
VTS LAZ 125
VTS LAZ 160
VTS LAZ 200
VTS LAZ 250
VTS LAZ 320

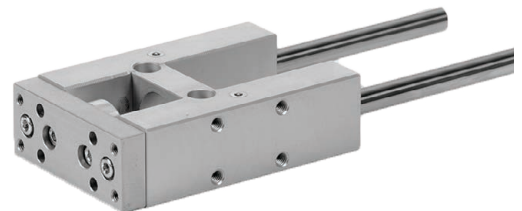
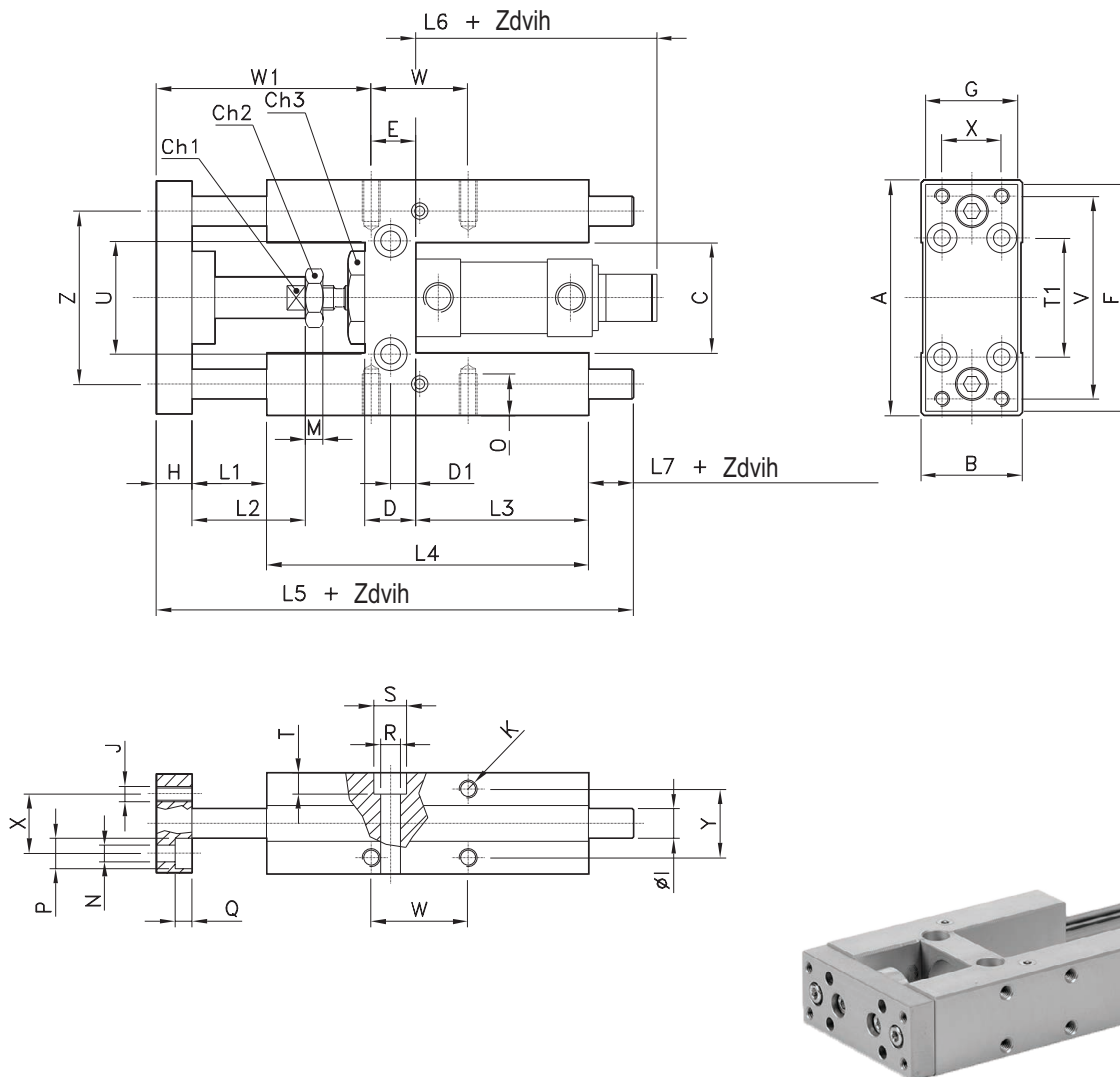

Lineárne H vedenie | klzné ložisko

RHS

Typ	Zdvih	Priemer piestu	A	B	C	Ch1	Ch2	Ch3	D	D1	E
RHS 12-16/...	50-500	Ø12-16	69	30	30	8	10	24	12	6	8
RHS 20/...	50-500	Ø20	79	34	37	12	13	27	17	8,5	15
RHS 25/...	50-500	Ø25	79	34	37	12	17	27	17	8,5	15

Typ	F	G	H	Øl	J	K	L1	L2	L3	L4	L5	L6	L7	M
RHS 12-16/...	66	29	10	10	M4	M4	-	18	46	68	124	-	20,5	4
RHS 20/...	78	32	12	12	M5	M6	3	18	58	108	166	43	21	5
RHS 25/...	78	32	12	12	M5	M6	3	18	58	108	166	43	21	6

Typ	N	O	P	Q	R	S	T	T1	U	V	W	W1	X	Y	Z
RHS 12-16/...	4,5	6	8	4,5	5,5	9	5,5	32	24	58	18	-	18	22	49,5
RHS 20/...	5,5	9	10	7,5	6,5	11	6,5	38	38	68	32,5	50	20	23	58
RHS 25/...	5,5	9	10	7,5	6,5	11	6,5	38	38	68	32,5	50	20	23	58

Lineárne vedenie pre kruhové valce | ISO 6432

strana 154

RHSL

Lineárne H vedenie | klzné ložisko | predĺžená spojka

Typ	Zdvih	Priemer piestu	A	B	C	Ch1	Ch2	Ch3	D	D1	E
RHSL 12-16/...	50-500	Ø12-16	69	30	30	8	10	24	12	6	8
RHSL 20/...	50-500	Ø20	79	34	37	12	13	27	17	8,5	15
RHSL 25/...	50-500	Ø25	79	34	37	12	17	27	17	8,5	15

Typ	F	G	H	ØI	J	K	L1	L2	L3	L4	L5	L6	L7	M
RHSL 12-16/...	66	29	10	10	M 4	M 4	25	18	46	68	123,5	73	20,5	4
RHSL 20/...	78	32	12	12	M 5	M 6	25	40	58	108	166	87	21	5
RHSL 25/...	78	32	12	12	M 5	M 6	25	40	58	108	166	87	21	6

Typ	N	O	P	Q	R	S	T	T1	U	V	W	W1	X	Y	Z
RHSL 12-16/...	4,5	6	8	4,5	5,5	9	5,5	32	24	58	18	-	18	22	49,5
RHSL 20/...	5,5	9	10	7,5	6,5	11	6,5	38	38	68	32,5	50	20	23	58
RHSL 25/...	5,5	9	10	7,5	6,5	11	6,5	38	38	68	32,5	50	20	23	58

RHG

Lineárne H vedenie | guľôčkové ložisko

Typ	Zdvih	Priemer piestu	A	B	C	Ch1	Ch2	Ch3	D	D1	E
RHG 12-16/...	50-500	Ø12-16	69	30	30	8	10	24	12	6	8
RHG 20/...	50-500	Ø20	79	34	37	12	13	27	17	8,5	15
RHG 25/...	50-500	Ø25	79	34	37	12	17	27	17	8,5	15

Typ	F	G	H	ØI	J	K	L1	L2	L3	L4	L5	L6	L7	M
RHG 12-16/...	66	29	10	8	M 4	M 4	-	18	46	68	123,5	-	20,5	4
RHG 20/...	78	32	12	10	M 5	M 6	3	18	58	108	166	43	21	5
RHG 25/...	78	32	12	10	M 5	M 6	3	18	58	108	166	43	21	6

Typ	N	O	P	Q	R	S	T	T1	U	V	W	W1	X	Y	Z
RHG 12-16/...	4,5	6	8	4,5	5,5	9	5,5	32	24	58	18	-	18	22	49,5
RHG 20/...	5,5	9	10	7,5	6,5	11	6,5	38	38	68	32,5	50	20	23	58
RHG 25/...	5,5	9	10	7,5	6,5	11	6,5	38	38	68	32,5	50	20	23	58

RHGL

Lineárne H vedenie | guľôčkové ložisko | predĺžená spojka

Typ	Zdvih	Priemer piestu	A	B	C	Ch1	Ch2	Ch3	D	D1	E
RHGL 12-16/...	50-500	Ø12-16	69	30	30	8	10	24	12	6	8
RHGL 20/...	50-500	Ø20	79	34	37	12	13	27	17	8,5	15
RHGL 25/...	50-500	Ø25	79	34	37	12	17	27	17	8,5	15

Typ	F	G	H	ØI	J	K	L1	L2	L3	L4	L5	L6	L7	M
RHGL 12-16/...	66	29	10	8	M 4	M 4	25	18	46	68	123,5	73	20,5	4
RHGL 20/...	78	32	12	10	M 5	M 6	25	40	58	108	166	87	21	5
RHGL 25/...	78	32	12	10	M 5	M 6	25	40	58	108	166	87	21	6

Typ	N	O	P	Q	R	S	T	T1	U	V	W	W1	X	Y	Z
RHGL 12-16/...	4,5	6	8	4,5	5,5	9	5,5	32	24	58	18	-	18	22	49,5
RHGL 20/...	5,5	9	10	7,5	6,5	11	6,5	38	38	68	32,5	50	20	23	58
RHGL 25/...	5,5	9	10	7,5	6,5	11	6,5	38	38	68	32,5	50	20	23	58

Lineárne vedenie pre normalizované valce | ISO 15552

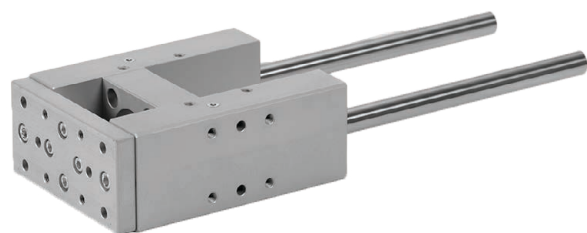
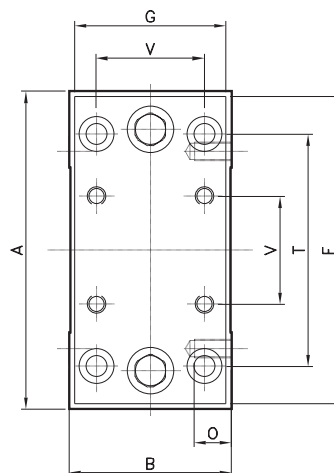
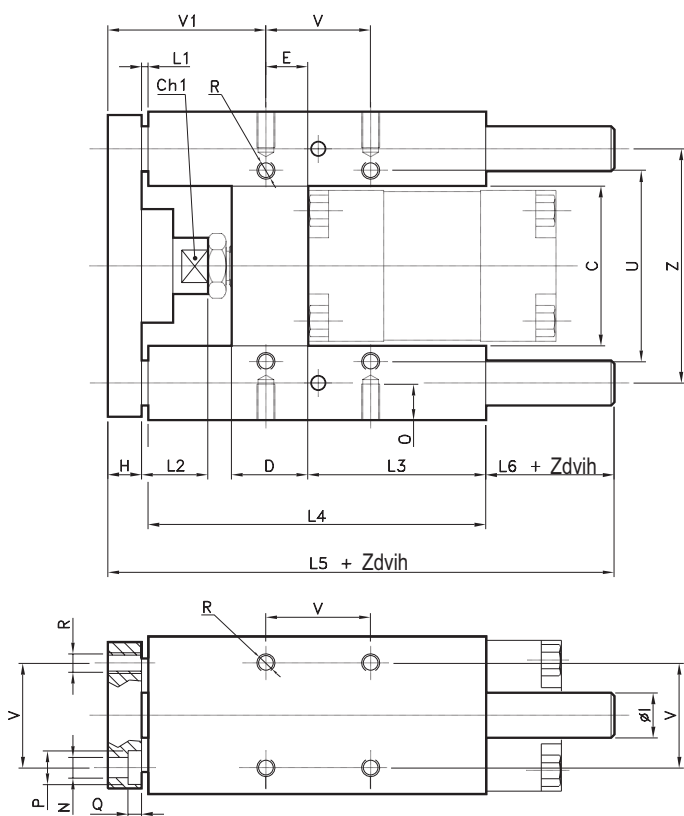

Lineárne H vedenie | klzné ložisko

DHS

Typ	Zdvih	Priemer piestu	A	B	C	Ch1	D	E	F	G	H	Ø1
DHS 32/...	50-500	Ø32	97	49	51	15	24	4,3	93	45	12	12
DHS 40/...	50-500	Ø40	115	58	58,2	15	28	11	112	55	12	16
DHS 50/...	50-500	Ø50	137	70	70,2	20	34	18,8	134	65	15	20
DHS 63/...	50-500	Ø63	152	85	85,2	20	34	15,3	147	80	15	20
DHS 80/...	50-500	Ø80	189	105	105,5	26	50	25	180	100	20	25
DHS 100/...	50-500	Ø100	213	130	130,5	26	55	30	206	120	20	25

Typ	L1	L2	L3	L4	L5	L6	N	O	P	Q	R	T	U	V	V1	Z
DHS 32/...	3	19	75	125	187	47	6,6	12	11	6,5	M 6	78	61	32,5	60,7	74
DHS 40/...	3	24	80	140	207	52	6,6	12	11	6,5	M 6	84	69	38	64	87
DHS 50/...	3	27	78	148	223	57	9	16	15	8,5	M 8	100	85	46,5	69,2	104
DHS 63/...	3	27	106	178	243	47	9	16	15	9	M 8	105	100	56,5	74,7	119
DHS 80/...	3	27	111	195	267	49	11	20	18	11	M 10	130	130	72	82	148
DHS 100/...	3	27	128	218	290	49	11	20	18	11	M 10	150	150	89	83	173

Lineárne H vedenie | klzné ložisko

DHSL

Typ	Zdvih	Priemer piestu	A	B	C	Ch1	D	E	F	G	H	Ø1
DHSL 32/...	50-500	Ø32	97	49	51	15	24	4,3	93	45	12	12
DHSL 40/...	50-500	Ø40	115	58	58,2	15	28	11	112	55	12	16
DHSL 50/...	50-500	Ø50	137	70	70,2	20	34	18,8	134	65	15	20
DHSL 63/...	50-500	Ø63	152	85	85,2	20	34	15,3	147	80	15	20
DHSL 80/...	50-500	Ø80	189	105	105,5	26	50	25	180	100	20	25
DHSL 100/...	50-500	Ø100	213	130	130,5	26	55	30	206	120	20	25

Lineárne vedenie pre normalizované valce | ISO 15552

Typ	L1	L2	L3	L4	L5	L6	N	O	P	Q	R	T	U	V	V1	Z
DHSL 32/...	25	42	75	125	187	25	6,6	12	11	6,5	M 6	78	61	32,5	82,7	74
DHSL 40/...	25	42	80	140	207	30	6,6	12	11	6,5	M 6	84	69	38	86	87
DHSL 50/...	25	50	78	148	223	35	9	16	15	8,5	M 8	100	85	46,5	91,2	104
DHSL 63/...	25	50	106	178	243	25	9	16	15	9	M 8	105	100	56,5	96,7	119
DHSL 80/...	25	50	111	195	267	27	11	20	18	11	M 10	130	130	72	104	148
DHSL 100/...	25	50	128	218	290	27	11	20	18	11	M 10	150	150	89	105	173

DHG

Lineárne H vedenie | guľôčkové ložisko

Typ	Zdvih	Priemer piestu	A	B	C	Ch1	D	E	F	G	H	ØI
DHG 32/...	50-500	Ø32	97	49	51	15	24	4,3	93	45	12	12
DHG 40/...	50-500	Ø40	115	58	58,2	15	28	11	112	55	12	16
DHG 50/...	50-500	Ø50	137	70	70,2	20	34	18,8	134	65	15	20
DHG 63/...	50-500	Ø63	152	85	85,2	20	34	15,3	147	80	15	20
DHG 80/...	50-500	Ø80	189	105	105,5	26	50	25	180	100	20	25
DHG 100/...	50-500	Ø100	213	130	130,5	26	55	30	206	120	20	25

Typ	L1	L2	L3	L4	L5	L6	N	O	P	Q	R	T	U	V	V1	Z
DHG 32/...	3	19	75	125	187	47	6,6	12	11	6,5	M 6	78	61	32,5	60,7	74
DHG 40/...	3	24	80	140	207	52	6,6	12	11	6,5	M 6	84	69	38	64	87
DHG 50/...	3	27	78	148	223	57	9	16	15	8,5	M 8	100	85	46,5	69,2	104
DHG 63/...	3	27	106	178	243	47	9	16	15	9	M 8	105	100	56,5	74,7	119
DHG 80/...	3	27	111	195	267	49	11	20	18	11	M 10	130	130	72	82	148
DHG 100/...	3	27	128	218	290	49	11	20	18	11	M 10	150	150	89	83	173

DHGL

Lineárne H vedenie | guľôčkové ložisko | predĺžená spojka

Typ	Zdvih	Priemer piestu	A	B	C	Ch1	D	E	F	G	H	ØI
DHGL 32/...	50-500	Ø32	97	49	51	15	24	4,3	93	45	12	12
DHGL 40/...	50-500	Ø40	115	58	58,2	15	28	11	112	55	12	16
DHGL 50/...	50-500	Ø50	137	70	70,2	20	34	18,8	134	65	15	20
DHGL 63/...	50-500	Ø63	152	85	85,2	20	34	15,3	147	80	15	20
DHGL 80/...	50-500	Ø80	189	105	105,5	26	50	25	180	100	20	25
DHGL 100/...	50-500	Ø100	213	130	130,5	26	55	30	206	120	20	25

Typ	L1	L2	L3	L4	L5	L6	N	O	P	Q	R	T	U	V	V1	Z
DHGL 32/...	25	42	75	125	187	25	6,6	12	11	6,5	M 6	78	61	32,5	82,7	74
DHGL 40/...	25	42	80	140	207	30	6,6	12	11	6,5	M 6	84	69	38	86	87
DHGL 50/...	25	50	78	148	223	35	9	16	15	8,5	M 8	100	85	46,5	91,2	104
DHGL 63/...	25	50	106	178	243	25	9	16	15	9	M 8	105	100	56,5	96,7	119
DHGL 80/...	25	50	111	195	267	27	11	20	18	11	M 10	130	130	72	104	148
DHGL 100/...	25	50	128	218	290	27	11	20	18	11	M 10	150	150	89	105	173